

VALVOSIDER

MANUFACTURER OF VALVES

GATE VALVES

CATALOGUE

R. 05/17

ASME

DIN

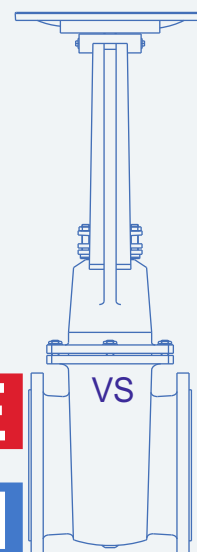

VALVOSIDER s.r.l.

Via S. Rocco, 2 - P.O. BOX 76 - 13011 Borgosesia (VC) - Italy

Phone: +39 0163 22991 - Fax: +39 0163 21537

e-mail: valvo@valvosider.com - <http://www.valvosider.com>



Main Location in Borgosesia



Second Location in Borgosesia

1 The Company

p. 4

2 Gate valves

p. 7

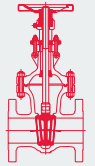

3 Globe valves

p. 19

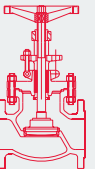

ASME

4 Check valves

p. 37

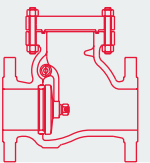

5 Strainers

p. 53

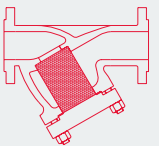

6 Gate valves

p. 59

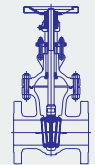

7 Globe valves

p. 71

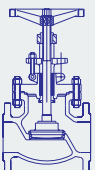

DIN

8 Check valves

p. 91

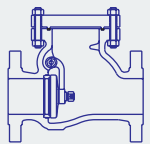

9 Strainers

p.109

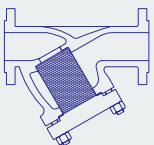

10 Technical data

p.115

BORGOSIESIA AREA MAP

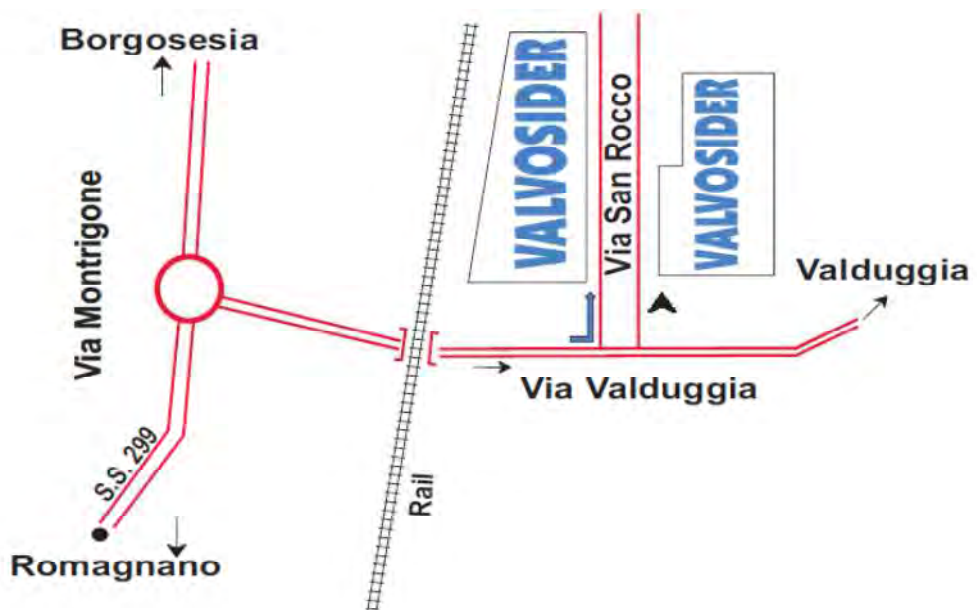
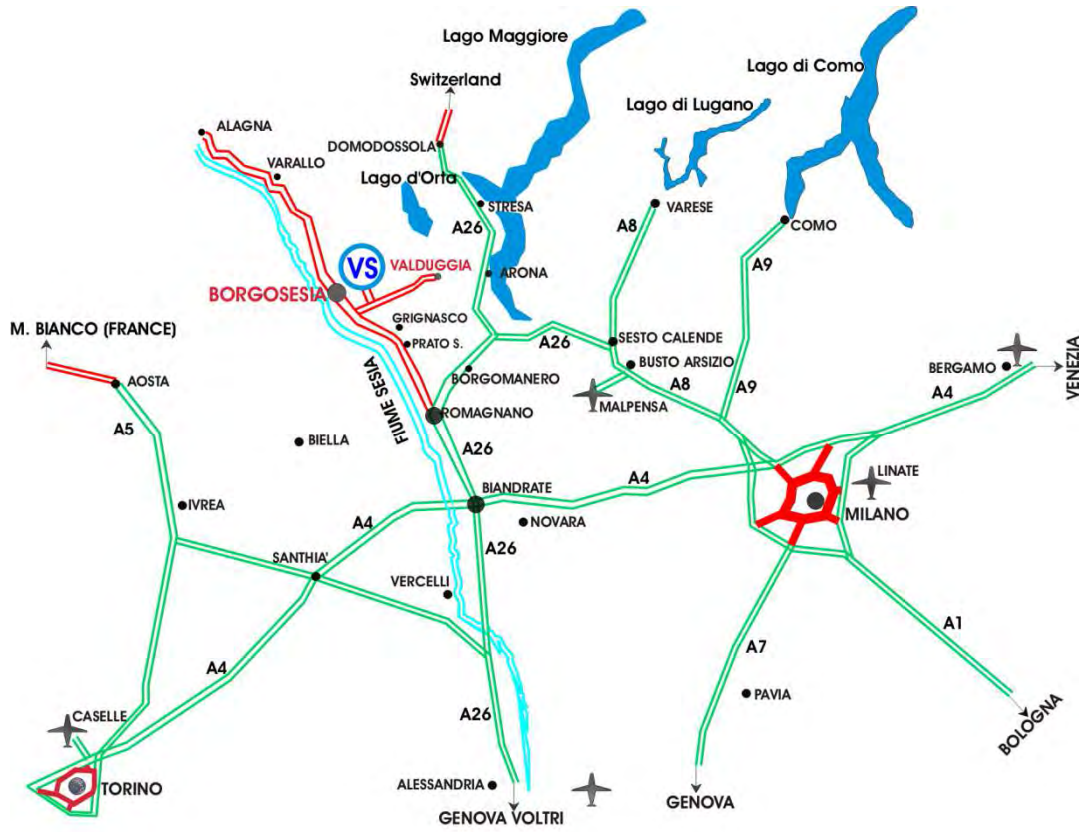



COMPANY INFORMATION & LOCATION

Valvosider was founded in 1951 as a manufacturer of industrial valves and, after more than 60 years of continuous growth, has become a valve manufacturer of international reputation. The production encompasses a wide range of valves meeting the requirements of the chemical, petrochemical, marine, oil (on and offshore), gas and power plant industries.

Our many years of experience in producing top quality products enable us to bring industry leading innovations to our customers.

We are certified by the following organizations:

ISO 9001:2008 RINA / IQNET
PRESSURE EQUIPMENT DIRECTIVE (2014/68/UE) - TÜV
ATEX DIRECTIVE 2014/68/UE - VALVOSIDER
API 600-0020 / AMERICAN PETROLEUM INSTITUTE
API 6D-0166 / AMERICAN PETROLEUM INSTITUTE
API 6A-0992 / AMERICAN PETROLEUM INSTITUTE
AD 2000 MERKBLATT HP0 /A4 / EN ISO 3834-2 - TÜV
API 622 / API 624 FUGITIVE EMISSION - TÜV
ISO 15848-1 Class BH FUGITIVE EMISSION - TÜV
TA-LUFT FUGITIVE EMISSION - TÜV
VDI 2440 - TÜV
FIRE SAFE API 607/BS EN ISO 10497/BS EN ISO 6755-2 - TÜV
TR CU 010/2011 & 032/2013
ACHILLES JQS
Canadian Registration Numbers (CRN)
API 591 - TÜV
SIL IEC 61508-1÷7:2010 - TÜV

Valvosider is located in Northern Italy in the town of Borgosesia between Milan and Turin, approximately one hour drive from either city.

The closest airport is Malpensa International Airport in Milan approximately a 45 minutes drive.

Genoa is approximately 150 kilometers and is the nearest Maritime Port.

The plant is approximately 96,000 square meters with a 37,800 square meters of covered structure.

COMPANY STRATEGY

We will continue changing the way we do business focusing on the customer's needs and our company's Vision, Mission & Values.

VISION:

Valvosider S.r.l. is a family owned company committed to provide its clients with a product which conforms with the requirements of the contract and the client's needs at a fair cost, within the contractual delivery time, with the highest possible safety standards, while at the same time protecting the well-being of the natural environment and our community.

MISSION:

As an international valve manufacturer it continues providing quality valves and meeting the client's specified requirements. Valvosider continues to be a strong source of income for the community, a safe environment for all employees and keeps embracing new ideas and ways of operation. Valvosider delivers what it promises to its clients building strong relationships. Let's keep improving our business and ourselves for that is a the reason for living.

VALUES:

Valvosider is committed of providing our clients, employees and our community with the best product and work environment by doing always our best. Respect, integrity, support, knowledge is our way of life.

DESCRIPTION OF A TYPICAL GATE VALVE

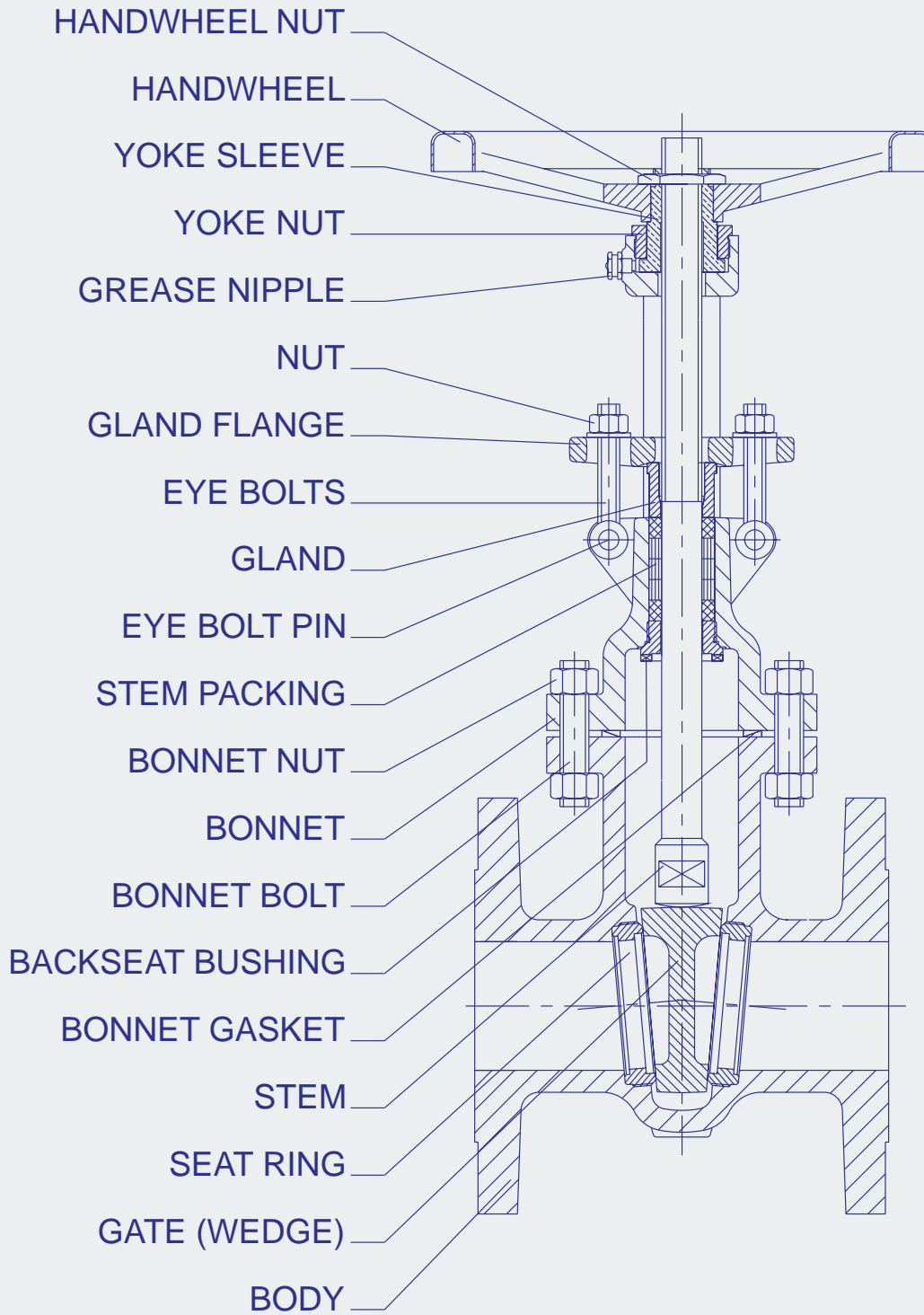

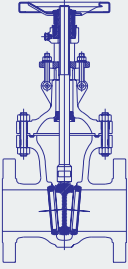
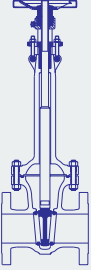
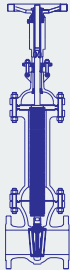
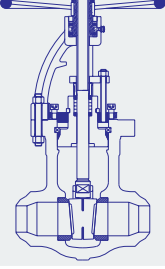
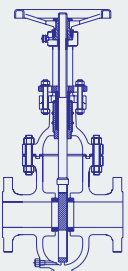
	TYPE	CLASS	SIZES	FIG. N
	GATE VALVES	150	2" - 48"	450
	BOLTED BONNET	300	2" - 48"	451
		600	2" - 40"	452
		900	2" - 24"	453
		1500	2" - 24"	454
		2500	2" - 12"	455
page 8				
	GATE VALVES	150	2" - 40"	450EB
	CRYOGENIC EXTENDED BONNET	300	2" - 40"	451EB
		600	2" - 24"	452EB
		900	2" - 24"	453EB
		1500	2" - 24"	454EB
page 10				
	GATE VALVES	150	2" - 24"	450SO
	BELLOW SEAL	300	2" - 24"	451SO
		600	2" - 24"	452SO
		900	2" - 16"	453SO
		1500	2" - 16"	454SO
page 12				
	GATE VALVES	600	2" - 24"	P52
	PRESSURE SEAL	900	2" - 24"	P53
		1500	2" - 24"	P54
		2500	2" - 24"	P55
page 14				
	GATE VALVES	150	3" - 40"	T50
	THROUGH CONDUIT	300	3" - 40"	T51
		600	3" - 40"	T52
		900	3" - 24"	T53
		1500	3" - 24"	T54
page 16				

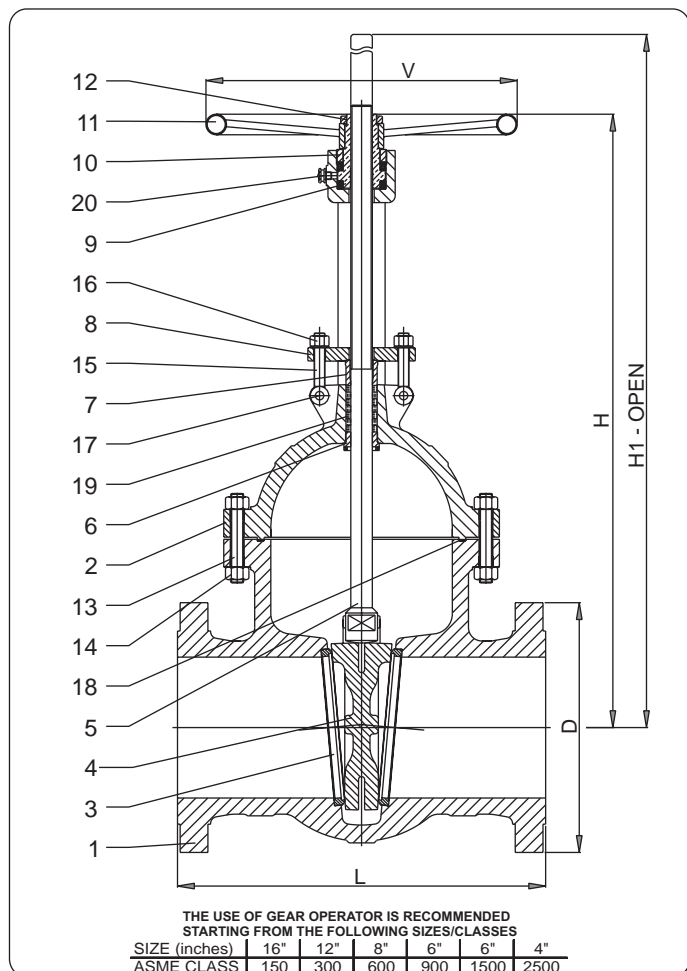

standard features

- **Description** BOLTED BONNET
OUTSIDE SCREW AND YOKE
RISING STEM
NON RISING HANDWHEEL
RENEWABLE SEATS
- **Design** API 600
BS 1414
- **Face to face** ASME B16.10
- **Flanges** ASME B16.5 FROM 2" TO 24"
ASME B16.47 FROM 26"
BW TO ASME B16.25
- **Testing** API 598
API 6D
BS 6755
- **Rating** ASME B16.34
- **Marking** MSS-SP 25
CE - PED
- **Certificates** EN 10204 - 3.1 B

PART NAME	W45x	L45x	M45x	C45x	B45x	E45x	D45x	F45x	H45x
1 Body	WCB	LCB	WC6	C5	C12	CF8	CF8C	CF8M	CF3M
2 Bonnet	WCB	LCB	WC6	C5	C12	CF8	CF8C	CF8M	CF3M
3 Seat ring surface	F6A (1)	F6A (1)	F6A (1)	F6A (1)	F6A (1)	F304 (1)	F321 (1)	F316 (1)	F316L (1)
4 Wedge seat surfaces	F6A (2)	F6A (2)	F6A (2)	F6A (2)	F6A (2)	F304 (2)	F321 (2)	F316 (2)	F316L (2)
5 Stem	F6A (3)	F6A (3)	F6A (3)	F6A (3)	F6A (3)	F304 (3)	F321 (3)	F316 (3)	F316L (3)
6 Back seat	F6A (3)	F6A (3)	F6A (3)	F6A (3)	F6A (3)	F304 (3)	F321 (3)	F316 (3)	F316L (3)
7 Gland	F6A (3)	F6A (3)	F6A (3)	F6A (3)	F6A (3)	F304 (3)	F321 (3)	F316 (3)	F316L (3)
8 Gland flange	A105	F316	F316	F316	F316	F316	F316	F316	F316L
9 Yoke sleeve	B148 9A (4)	B148 9A (4)	Nod.Iron	Nod.Iron	Nod.Iron	B148 9A (4)	B148 9A (4)	B148 9A (4)	B148 9A (4)
10 Yoke nut	A105	A350 LF2	A105	A105	A105	F316	F316	F316	F316
11 Handwheel					Steel				
12 Handwheel nut					A105				
13 Bolts	B7	L7	B16	B16	B16	B8	B8	B8	B8
14 Nuts	2H	G4	G4	G4	G4	G8	G8	G8	G8
15 Eye bolts	B7	B7	B8	B8	B8	B8	B8	B8	B8
16 Nuts	2H	2H	2H	2H	2H	G8	G8	G8	G8
17 Eye bolt pin	B7	B7	B7	B7	B7	B8	B8	B8	B8
18 Gasket (5)	ANSI 150: S.S. reinforced graphite - ANSI 300-600-900-1500: S.S. Spiral wound reinf. graphite/RTJ - ANSI 2500: RTJ								
19 Packing					Graphite rings & wiper rings (6)				
20 Grease nipple					A105				

(1) On request: faced with Stellite® - Monel® - Hastelloy® - other materials
 (2) On request: faced with Stellite® - Monel® - Hastelloy® - other materials
 (3) On request: 17 Cr - Monel® - Hastelloy® - other materials

(4) On request: Nodular Iron - Nitronic 60
 (5) On request: PTFE - other materials
 (6) On request: PTFE - other materials

All data, subject to technical changes, are only for information and not for official use.

GATE VALVES

ASME 150 - 300 - 600 - 900 - 1500 - 2500

VALVOSIDER
MANUFACTURER OF VALVES

FIG. N. 450 - GATE VALVES OVAL BODY ASME CLASS 150

SIZE	2"	2½"	3"	4"	5"	6"	8"	10"	12"	14"	16"	18"	20"	24"	28"	30"	32"	34"	36"	40"	42"	48"
L RF	178	191	203	229	254	267	292	330	356	381	406	432	457	508	610	610	660	711	711	762	787	864
L BW	216	241	282	305	381	403	419	457	502	571	610	660	711	813	914	914	965	1016	1016	1168	1397	1270
D	152	178	191	229	254	279	343	406	483	533	597	635	699	813	927	984	1060	1111	1168	1289	1346	1511
V	200	200	225	250	250	300	400	500	500	600	600	700	700	800	G.O.	G.O.	G.O.	G.O.	G.O.	G.O.	G.O.	G.O.
H	350	420	440	480	560	600	775	1050	1240	1300	1500	1650	1800	2200	2600	2600	2600	3000	3000	3200	3200	3500
H1	400	480	510	580	695	750	980	1300	1540	1650	1900	2100	2300	2800	3350	3400	3450	3900	3950	4200	4250	4500

FIG. N. 451 - GATE VALVES ASME CLASS 300

SIZE	2"	2½"	3"	4"	5"	6"	8"	10"	12"	14"	16"	18"	20"	24"	28"	30"	32"	34"	36"	40"	42"	48"
L RF/BW	216	241	282	305	381	403	419	457	502	762	838	914	991	1143	1346	1397	1524	1626	1727	1930	1981	2235
L RTJ	232	257	298	321	397	419	435	473	518	778	854	930	1010	1165	1371	1422	1552	1654	1755	--	--	--
D	165	191	210	254	279	318	381	445	521	584	648	711	775	914	1035	1092	1149	1207	1270	1238	1289	1467
V	200	200	225	250	300	400	500	500	600	600	700	700	800	900	G.O.	G.O.	G.O.	G.O.	G.O.	G.O.	G.O.	G.O.
H	400	430	500	530	620	730	910	1110	1240	1400	1580	1700	1900	2150	2530	3000	3000	3360	3360	3890	3890	4330
H1	450	490	580	630	745	880	1110	1360	1540	1750	1980	2150	2400	2750	3350	3850	3900	4300	3950	4950	5110	5280

FIG. N. 452 - GATE VALVES ASME CLASS 600

SIZE	2"	2½"	3"	4"	5"	6"	8"	10"	12"	14"	16"	18"	20"	24"	28"	30"	32"	34"	36"	40"	42"	48"
L RF/BW	292	330	356	432	508	559	660	787	838	889	991	1092	1194	1397	1549	1651	1778	1930	2082	2286	--	--
L RTJ	295	333	359	435	511	562	663	791	841	892	994	1095	1200	1407	1562	1664	1794	1946	2099	--	--	--
D	165	191	210	273	330	356	420	508	559	603	686	743	813	940	1073	1130	1194	1245	1314	1321	--	--
V	200	250	250	400	400	500	600	700	700	800	900	1000	1600	G.O.	G.O.	G.O.	G.O.	G.O.	G.O.	G.O.	--	--
H	450	500	540	670	686	810	970	1155	1330	1480	1680	1826	1930	2160	2390	2880	2950	3030	3090	3620	--	--
H1	500	570	620	770	810	960	1170	1410	1630	1830	2100	2280	2450	2800	3137	3680	3803	3937	4050	4687	--	--

FIG. N. 453 - GATE VALVES ASME CLASS 900

SIZE	2"	3"	4"	6"	8"	10"	12"	14"	16"	18"	20"	24"	28"
L RF/BW	368	381	457	610	737	838	965	1029	1130	1219	1321	1549	--
L RTJ	371	384	460	613	740	841	968	1038	1140	1232	1334	1568	--
D	216	241	292	381	470	546	610	641	705	787	857	1041	--
V	250	300	400	600	650	700	900	1000	G.O.	G.O.	G.O.	G.O.	--
H	450	600	670	890	1114	1255	1439	1585	1639	1835	1970	2230	--
H1	500	680	770	1050	1320	1520	1750	1950	2050	2300	2500	2850	--

FIG. N. 454 - GATE VALVES ASME CLASS 1500

SIZE	2"	3"	4"	6"	8"	10"	12"	14"	16"	18"	20"	24"	28"
L RF/BW	368	470	546	705	832	991	1130	1257	1384	1537	1664	1943	--
L RTJ	371	473	549	711	842	1000	1146	1276	1407	1559	1686	1972	--
D	216	267	311	394	483	584	673	749	826	914	984	1168	--
V	250	400	500	600	700	900	1600	1600	G.O.	G.O.	G.O.	G.O.	--
H	450	620	760	930	1148	1336	1454	1645	1815	1835	1970	2230	--
H1	500	700	870	1090	1360	1520	1750	1950	2050	2300	2500	2850	--

FIG. N. 455 - GATE VALVES ASME CLASS 2500

SIZE	2"	3"	4"	6"	8"	10"	12"	14"	16"	18"	20"	24"	28"
L RF/BW	451	578	673	914	1022	1270	1422	--	--	--	--	--	--
L RTJ	454	584	683	927	1038	1292	1445	--	--	--	--	--	--
D	235	305	356	483	552	673	762	--	--	--	--	--	--
V	250	400	500	600	700	G.O.	G.O.	--	--	--	--	--	--
H	450	620	760	930	1148	1255	1439	--	--	--	--	--	--
H1	500	700	870	1090	1360	1520	1750	--	--	--	--	--	--

All dimensions in mm (except where differently indicated)

All data, subject to technical changes, are only for information and not for official use.

features on request

- TOP FLANGE TO ISO 5210
- GEAR OPERATOR
- CHAIN WHEEL OPERATOR
- PNEUMATIC ACTUATOR
- HYDRAULIC ACTUATOR
- ELECTRIC ACTUATOR
- POSITION INDICATOR
- LIMIT SWITCHES
- LOCKING / INTERLOCK SYSTEM
- PTFE SOFT SEATS
- STEM PROTECTION
- STEM EXTENSION
- LANTERN RING
- EXTENDED STUFFING BOX
- LIVE LOADED PACKING
- DRAIN PLUG
- BY PASS
- BW ENDS
- DIN CONNECTIONS

VALVOSIDER s.r.l. - Via S. Rocco, 2 - P.O. BOX 76 - 13011 Borgosesia (VC) - Italy
Phone: +39016322991 - Fax: +39016321537 - www.valvosider.com - e-mail: valvo@valvosider.com

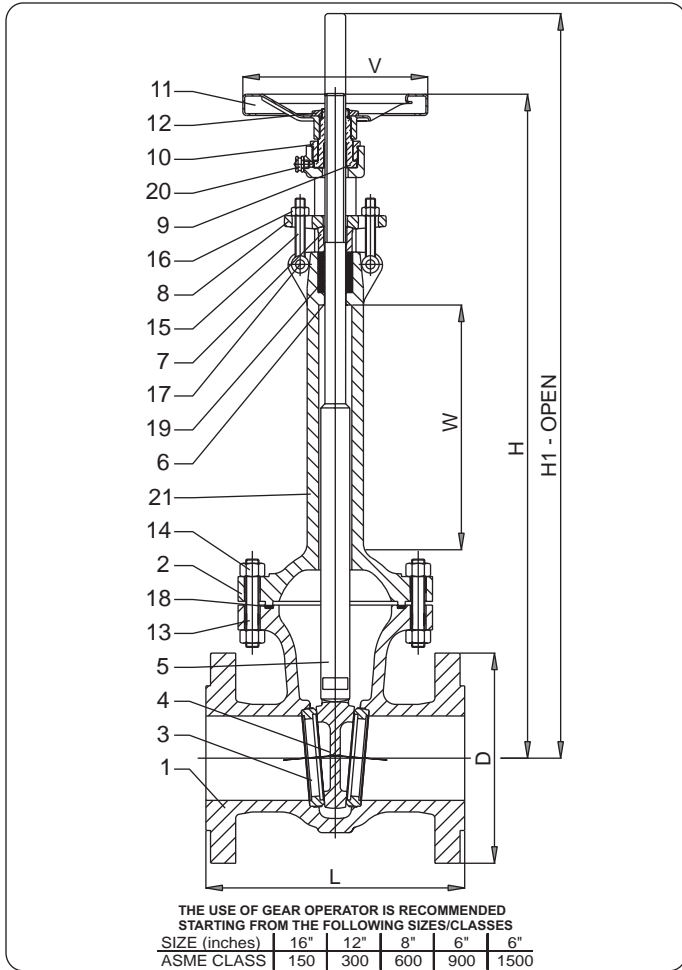

standard features

- **Description** EXTENDED BONNET
BOLTED BONNET
OUTSIDE SCREW AND YOKE
RISING STEM
NON RISING HANDWHEEL
RENEWABLE SEATS
- **Design** API 600
BS 1414
- **Face to face** ASME B16.10
- **Flanges** ASME B16.5 FROM 2" TO 24"
ASME B16.47 FROM 26"
- **Testing** API 598
API 6D
BS 6755
- **Rating** ASME B16.34
- **Marking** MSS-SP 25
CE - PED
- **Certificates** EN 10204 – 3.1 B

PART NAME	E45xEB	F45xEB
1 Body	CF8	CF8M
2 Bonnet	CF8	CF8M
3 Seat ring surface	F316 (1)	F316 (1)
4 Wedge seat surfaces	F316 (2)	F316 (2)
5 Stem	F316 (3)	F316 (3)
6 Back seat (integral)	CF8 (2)	CF8M (2)
7 Gland	F316 (3)	F316 (3)
8 Gland flange	F316	F316
9 Yoke sleeve	B148 9A (4)	B148 9A (4)
10 Yoke nut	F316	F316
11 Handwheel	Steel	Steel
12 Handwheel nut	A105	A105
13 Bolts	B8	B8
14 Nuts	G8	G8
15 Eye bolts	B8	B8
16 Nuts	G8	G8
17 Eye bolt pin	B8	B8
18 Gasket	PTFE (5)	PTFE (5)
19 Packing	PTFE (6)	PTFE (6)
20 Grease nipple	F316	F316
21 Extension	F304L	F316L

- (1) On request: faced with Stellite® - Monel® - Hastelloy® - other materials
 (2) On request: faced with Stellite® - Monel® - Hastelloy® - other materials
 (3) On request: 17 Cr - Monel® - Hastelloy® - other materials

options

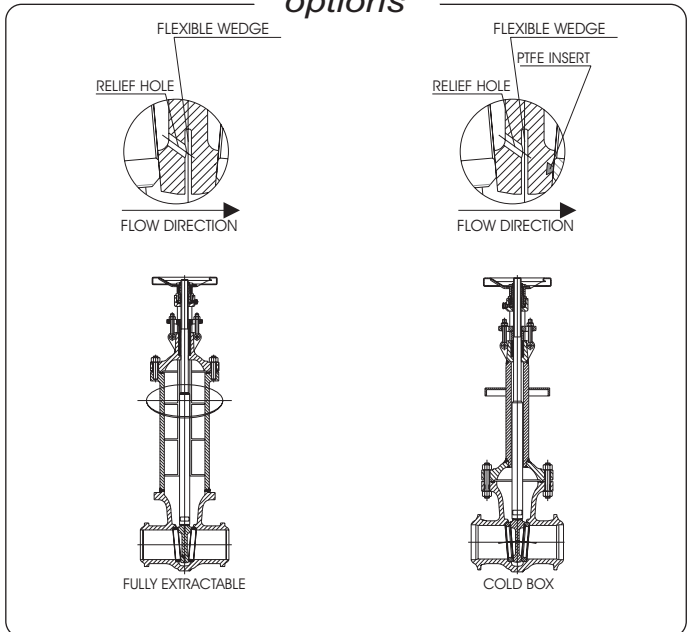

- (4) On request: Nodular Iron - Nitronic 60
 (5) On request: Graphite - other materials
 (6) On request: Graphite - other materials

All data, subject to technical changes, are only for information and not for official use.

CRYOGENIC GATE VALVES

ASME 150 - 300 - 600 - 900 - 1500

VALVOSIDER
MANUFACTURER OF VALVES

FIG. N. 450EB - CRYOGENIC GATE VALVES OVAL BODY ASME CLASS 150

SIZE	2"	2½"	3"	4"	5"	6"	8"	10"	12"	14"	16"	18"	20"	24"	28"	30"	32"	34"	36"	40"
L RF	178	191	203	229	254	267	292	330	356	381	406	432	457	508	610	610	660	711	711	762
L BW	216	241	282	305	381	403	419	457	502	571	610	660	711	813	914	914	965	1016	1016	1168
D	152	178	191	229	254	279	343	406	483	533	597	635	699	813	927	984	1060	1111	1168	1289
V	200	200	225	250	250	300	400	500	500	600	600	700	700	800	G.O.	G.O.	G.O.	G.O.	G.O.	G.O.
W	200	200	300	300	300	300	300	300	300	300	300	300	300	300	--	--	--	--	--	--
H	550	620	730	770	860	900	1075	1390	1540	1600	1800	1950	2100	2500	--	--	--	--	--	--
H1	600	690	810	870	990	1050	1280	1650	1850	1950	2200	2550	2800	3400	--	--	--	--	--	--

FIG. N. 451EB - CRYOGENIC GATE VALVES ASME CLASS 300

SIZE	2"	2½"	3"	4"	5"	6"	8"	10"	12"	14"	16"	18"	20"	24"	28"	30"	32"	34"	36"	40"
L RF/BW	216	241	282	305	381	403	419	457	502	762	838	914	991	1143	1346	1397	1524	1626	1727	1930
L RTJ	232	257	298	321	397	419	435	473	518	778	854	930	1010	1165	1371	1422	1552	1654	1755	--
D	165	191	210	254	279	318	381	445	521	584	648	711	775	914	1035	1092	1149	1207	1270	1238
V	200	200	225	250	300	400	500	500	600	600	700	700	800	900	G.O.	G.O.	G.O.	G.O.	G.O.	G.O.
W	200	200	300	300	300	300	300	300	300	300	300	300	300	300	--	--	--	--	--	--
H	600	630	800	830	920	1030	1210	1410	1540	1700	1880	2000	2200	2600	--	--	--	--	--	--
H1	650	700	880	930	1045	1180	1280	1660	1840	2050	2280	2150	2400	2750	--	--	--	--	--	--

FIG. N. 452EB - CRYOGENIC GATE VALVES ASME CLASS 600

SIZE	2"	3"	4"	6"	8"	10"	12"	14"	16"	18"	20"	24"
L RF/BW	292	356	432	559	660	787	838	889	991	1092	1194	1397
L RTJ	295	359	435	562	663	791	841	892	994	1095	1200	1407
D	165	210	273	356	419	508	559	603	686	743	813	940
V	200	250	400	500	600	700	700	800	900	1000	1600	G.O.
W	200	300	300	300	300	300	300	300	300	300	300	300
H	640	840	850	1100	1260	1455	1620	1780	1980	2130	2230	2460
H1	700	920	950	1250	1460	1710	1930	2130	2400	2580	2730	3100

FIG. N. 453EB - CRYOGENIC GATE VALVES ASME CLASS 900

SIZE	2"	3"	4"	6"	8"	10"	12"	14"	16"	18"	20"	24"
L RF/BW	368	381	457	610	737	838	965	1029	1130	1219	1321	1549
L RTJ	371	384	460	613	740	841	968	1038	1140	1232	1334	1568
D	216	241	292	381	470	546	610	641	705	787	857	1041
V	250	300	400	600	650	700	900	1000	G.O.	G.O.	G.O.	G.O.
W	200	300	300	300	300	300	300	300	300	300	300	300
H	650	900	970	1190	1414	1555	1739	1885	1939	2135	2270	2530
H1	700	980	1070	1350	1620	1820	2050	2250	2350	2600	2800	3150

FIG. N. 454EB - CRYOGENIC GATE VALVES ASME CLASS 1500

SIZE	2"	3"	4"	6"	8"	10"	12"	14"	16"	18"	20"	24"
L RF/BW	368	470	546	705	832	991	1130	1257	1384	1537	1664	1943
L RTJ	371	473	549	711	842	1000	1146	1276	1407	1559	1686	1972
D	216	267	311	394	483	584	673	749	826	914	984	1168
V	250	400	500	600	700	900	1600	1600	G.O.	G.O.	G.O.	G.O.
W	200	300	300	300	300	300	300	300	300	300	300	300
H	650	920	1060	1230	1448	1555	1739	1885	1939	2135	2270	2530
H1	700	1000	1170	1390	1660	1820	2050	2250	2350	2600	2800	3150

- features on request*
- TOP FLANGE TO ISO 5210
 - GEAR OPERATOR
 - CHAIN WHEEL OPERATOR
 - PNEUMATIC ACTUATOR
 - HYDRAULIC ACTUATOR
 - ELECTRIC ACTUATOR
 - POSITION INDICATOR
 - LIMIT SWITCHES
 - LOCKING / INTERLOCK SYSTEM
 - PTFE SOFT SEATS
 - STEM PROTECTION
 - STEM EXTENSION
 - LANTERN RING
 - EXTENDED STUFFING BOX
 - LIVE LOADED PACKING
 - DRAIN PLUG
 - BY PASS
 - BW ENDS
 - DIN CONNECTIONS

All dimensions in mm (except where differently indicated)

All data, subject to technical changes, are only for information and not for official use.

VALVOSIDER s.r.l. - Via S. Rocco, 2 - P.O. BOX 76 - 13011 Borgosesia (VC) - Italy
Phone: +39016322991 - Fax: +39016321537 - www.valvosider.com - e-mail: valvo@valvosider.com

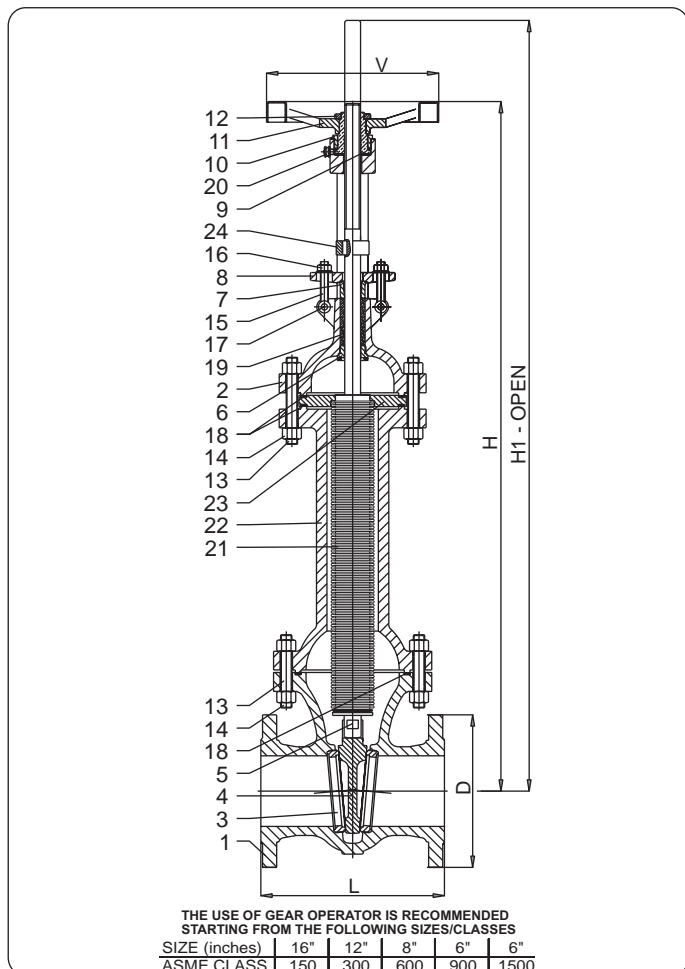

standard features

- **Description** BELLOW SEAL
BOLTED BONNET
OUTSIDE SCREW AND YOKE
RISING STEM
NON RISING HANDWHEEL
RENEWABLE SEATS
- **Design** API 600
BS 1414
- **Face to face** ASME B16.10
- **Flanges** ASME B16.5
BW TO ANSI B16.25
- **Testing** API 598
API 6D
BS 6755
- **Rating** ASME B16.34
- **Marking** MSS-SP 25
CE - PED
- **Certificates** EN 10204 – 3.1 B

PART NAME	W45xSO	L45xSO	M45xSO	C45xSO	B45xSO	E45xSO	D45xSO	F45xSO	H45xSO
1 Body	WCB	LCB	WC6	C5	C12	CF8	CF8C	CF8M	CF3M
2 Bonnet	WCB	LCB	WC6	C5	C12	CF8	CF8C	CF8M	CF3M
3 Seat ring surface	F6A (1)	F6A (1)	F6A (1)	F6A (1)	F6A (1)	F304 (1)	F321 (1)	F316 (1)	F316L (1)
4 Wedge seat surfaces	F6A (2)	F6A (2)	F6A (2)	F6A (2)	F6A (2)	F304 (2)	F321 (2)	F316 (2)	F316L (2)
5 Stem	F6A (3)	F6A (3)	F6A (3)	F6A (3)	F6A (3)	F304 (3)	F321 (3)	F316 (3)	F316L (3)
6 Back seat	F6A (3)	F6A (3)	F6A (3)	F6A (3)	F6A (3)	F304 (3)	F321 (3)	F316 (3)	F316L (3)
7 Gland	F6A (3)	F6A (3)	F6A (3)	F6A (3)	F6A (3)	F304 (3)	F321 (3)	F316 (3)	F316L (3)
8 Gland flange	A105	F316	F316	F316	F316	F316	F316	F316	F316L
9 Yoke sleeve	B148 9A (4)	B148 9A (4)	Nod.Iron	Nod.Iron	Nod.Iron	B148 9A (4)	B148 9A (4)	B148 9A (4)	B148 9A (4)
10 Yoke nut	A105	A105	A105	A105	A105	F316	F316	F316	F316L
11 Handwheel			← Steel →						
12 Handwheel nut			← A105 →						
13 Bolts	B7	L7	B16	B16	B16	B8	B8	B8	B8
14 Nuts	2H	G4	G4	G4	G4	G8	G8	G8	G8
15 Eye bolts	B7	B7	B8	B8	B8	B8	B8	B8	B8
16 Nuts	2H	2H	2H	2H	2H	G8	G8	G8	G8
17 Eye bolt pin	B7	B7	B7	B7	B7	B8	B8	B8	B8
18 Gasket			← S.S. reinforced graphite (5) →						
19 Packing			← Graphite rings & wiper rings (6) →						
20 Grease nipple			← A105 →						
21 Bellow			← A182 F321 →						
22 Extension	A105	LF2	F11	F5	F9	F304L	F347	F316L	F316L
23 Bellow flange			← A182 F321 →						
24 No rot. Device	F6A	F6A	F6A	F6A	F6A	F304	F321	F316	F316L

(1) On request: faced with Stellite® - Monel® - Hastelloy® - other materials
 (2) On request: faced with Stellite® - Monel® - Hastelloy® - other materials
 (3) On request: 17 Cr - Monel® - Hastelloy® - other materials

(4) On request: Nodular Iron - Nitronic 60
 (5) On request: PTFE - other materials
 (6) On request: PTFE - other materials

All data, subject to technical changes, are only for information and not for official use.

GATE VALVES BELLOW SEAL ASME 150 - 300 - 600 - 900 - 1500

VALVOSIDER
MANUFACTURER OF VALVES

FIG. N. 450SO - BELLOW GATE VALVES OVAL BODY ASME CLASS 150

SIZE	2"	2½"	3"	4"	5"	6"	8"	10"	12"	14"	16"	18"	20"	24"	---
L RF	178	191	203	229	254	267	292	330	356	381	406	432	457	508	---
L BW	216	241	282	305	381	403	419	457	502	571	610	660	711	813	---
D	152	178	191	229	254	279	343	406	483	533	597	635	699	813	---
V	200	200	225	250	250	300	400	500	500	600	600	700	700	800	---
H	610	675	820	940	1160	1530	1960	2350	2600	2980	3170	3550	4050	4650	---
H1	660	740	900	1040	1290	1680	2160	2600	2900	3350	3570	4000	4550	5250	---

FIG. N. 451SO - BELLOW GATE VALVES ASME CLASS 300

SIZE	2"	2½"	3"	4"	5"	6"	8"	10"	12"	14"	16"	18"	20"	24"	---
L RF/BW	216	241	282	305	381	403	419	457	502	762	838	914	991	1143	---
L RTJ	232	257	298	321	397	419	435	473	518	778	854	930	1010	1165	---
D	165	191	210	254	279	318	381	445	521	584	648	711	775	914	---
V	200	200	225	250	300	400	500	500	600	600	700	700	800	900	---
H	600	685	765	920	1070	1315	1700	2035	2395	2760	3135	3600	4080	4795	---
H1	650	750	840	1020	1200	1465	1900	2285	2700	3110	4535	4050	4580	5350	---

FIG. N. 452SO - BELLOW GATE VALVES ASME CLASS 600

SIZE	2"	3"	4"	6"	8"	10"	12"	14"	16"	18"	20"	24"	---	---	---
L RF/BW	292	356	432	559	660	787	838	889	991	1092	1194	1397	---	---	---
L RTJ	295	359	435	562	663	791	841	892	994	1095	1200	1407	---	---	---
D	165	210	273	356	419	508	559	603	686	743	813	940	---	---	---
V	200	250	400	500	600	700	900	800	900	1000	1600	G.O.	---	---	---
H	640	805	905	1360	1720	2120	2500	---	---	---	---	---	---	---	---
H1	690	880	1010	1510	1920	2370	2800	---	---	---	---	---	---	---	---

FIG. N. 453SO - BELLOW GATE VALVES ASME CLASS 900

SIZE	2"	3"	4"	6"	8"	10"	12"	14"	16"
L RF/BW	368	381	457	610	737	838	965	1029	1130
L RTJ	371	384	460	613	740	841	968	1038	1140
D	216	241	292	381	470	546	610	641	705
V	250	300	400	600	650	700	900	1000	G.O.
H	---	---	---	---	---	---	---	---	---
H1	---	---	---	---	---	---	---	---	---

FIG. N. 454SO - BELLOW GATE VALVES ASME CLASS 1500

SIZE	2"	3"	4"	6"	8"	10"	12"	14"	16"
L RF/BW	368	470	546	705	832	991	1130	1257	1384
L RTJ	371	473	549	711	842	1000	1146	1276	1407
D	216	267	311	394	483	584	673	749	826
V	250	400	500	600	700	900	1600	1600	1600
H	---	---	---	---	---	---	---	---	---
H1	---	---	---	---	---	---	---	---	---

features on request

- TOP FLANGE TO ISO 5210
- GEAR OPERATOR
- CHAIN WHEEL OPERATOR
- PNEUMATIC ACTUATOR
- HYDRAULIC ACTUATOR
- ELECTRIC ACTUATOR
- POSITION INDICATOR
- LIMIT SWITCHES
- LOCKING / INTERLOCK SYSTEM
- PTFE SOFT SEATS
- STEM PROTECTION
- STEM EXTENSION
- LANTERN RING
- EXTENDED STUFFING BOX
- LIVE LOADED PACKING
- DRAIN PLUG
- BY PASS
- BW ENDS
- DIN CONNECTIONS

All dimensions in mm (except where differently indicated)

All data, subject to technical changes, are only for information and not for official use.

VALVOSIDER s.r.l. - Via S. Rocco, 2 - P.O. BOX 76 - 13011 Borgosesia (VC) - Italy
Phone: +39016322991 - Fax: +39016321537 - www.valvosider.com - e-mail: valvo@valvosider.com

standard features

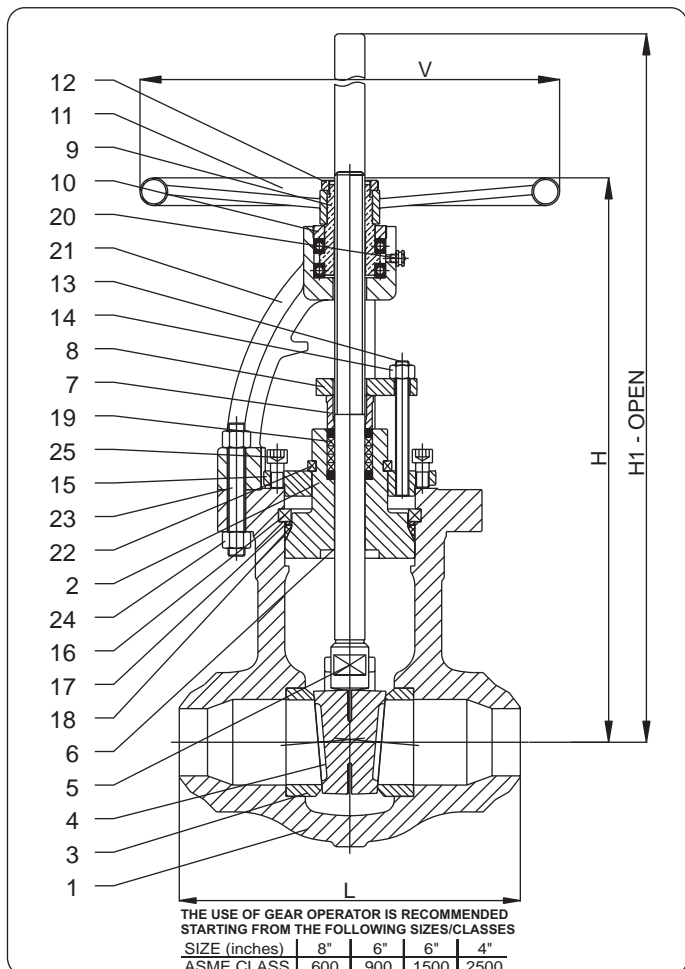

- **Description** ROUND BODY
PRESSURE SEAL BONNET
OUTSIDE SCREW AND YOKE
RISING STEM
NON RISING HANDWHEEL
INTEGRAL BACKSEAT
WELDED IN SEATS
FLEXIBLE WEDGE
- **Design** API 600 STYLE A
ASME B16.34
API 600 STYLE B on demand
- **Face to face** ASME B16.10
- **Ends** ASME B16.5
BW ENDS TO ASME B16.25
- **Testing** API 598
API 6D
BS 6755
- **Rating** ASME B16.34
- **Marking** MSS-SP 25
CE - PED
- **Certificates** EN 10204 - 3.1 B

PART NAME	WP5x	IP5x	MP5x	WCP5x	FP5x
1 Body	WCB	WC1	WC6	WC9	CF8M
2 Bonnet	WCB	WC1	WC6	WC9	CF8M
3 Seat - ring	A105 + HF (1)	F6A + HF (1)	F6A + HF (1)	F6A + HF (1)	F316 + HF (1)
4 Wedge seat surfaces	WCB + HF (1)	WC1 + HF (1)	WC6 + HF (1)	WC9 + HF (1)	CF8M + HF (1)
5 Stem	F6A (3)	F6A (3)	F6A (3)	F6A (3)	F316 (3)
6 Back seat (integral)		←	Stellite® (2)	→	
7 Gland	F6A (3)	F6A (3)	F6A (3)	F6A (3)	F316 (3)
8 Gland flange	A105	F316	F316	F316	F316
9 Yoke sleeve		←	B148 9A (4)	→	
10 Yoke nut	A 105	A 105	A 105	A 105	F316
11 Handwheel		←	Steel	→	
12 Handwheel nut		←	A105	→	
13 Bolts	B7	B16	B16	B16	B8
14 Nuts	2H	G4	G4	G4	G8
15 Retainer flange	A 105	A 105	A 105	A 105	F316
16 Segmented retainer ring	F6A	F6A	F6A	F6A	F316
17 Spacer ring	F6A	F6A	F6A	F6A	F316
18 Gasket		←	S.S. Reinforced Graphite (5)	→	
19 Packing		←	Graphite rings & wiper rings	→	
20 Grease nipple		←	Steel	→	
21 Yoke	WCB	WC1	WC6	WC9	CF8M
22 Segmented support ring	F6	F6	F6	F6	F316
23 Yoke / body bolt	B7	B16	B16	B16	B8
24 Yoke / body nut	2H	G4	G4	G4	G8
25 Bolts	B7	B16	B16	B16	B8

(1) On request: faced with Stellite® - Monel® - Hastelloy® - other materials
 (2) On request: faced with Monel® - Hastelloy® - other materials
 (3) On request: 17 Cr - Monel® - Hastelloy® - other materials

(4) On request: Nodular Iron - Nitronic 60
 (5) On request: Metal

All data, subject to technical changes, are only for information and not for official use.

PRESSURE SEAL GATE VALVES ASME 600 - 900 - 1500 - 2500

VALVOSIDER
MANUFACTURER OF VALVES

FIG. N. P52 - PRESSURE SEAL GATE VALVES ASME CLASS 600

SIZE	2"	3"	4"	6"	8"	10"	12"	14"	16"	18"	20"	24"
L RF	292	356	432	559	660	787	838	889	991	1092	1194	1397
L RTJ	295	359	435	562	663	791	841	892	994	1095	1200	1407
L BW	178	254	305	457	584	711	813	889	991	1092	1194	1397
V	200	250	400	500	600	700	G.O.	G.O.	G.O.	G.O.	G.O.	G.O.
H	500	550	590	840	970	1160	1300	1500	1780	2000	2150	2400
H1	550	630	690	990	1170	1410	1600	1850	2180	2450	2650	3000

FIG. N. P53 - PRESSURE SEAL GATE VALVES ASME CLASS 900

SIZE	2"	3"	4"	6"	8"	10"	12"	14"	16"	18"	20"	24"
L RF	368	381	457	610	737	838	965	1029	1130	1219	1321	1549
L RTJ	371	384	460	613	740	841	968	1038	1140	1232	1334	1568
L BW	216	305	356	508	660	787	914	991	1092	1143	1245	1397
V	250	300	400	500	G.O.	G.O.	G.O.	G.O.	G.O.	G.O.	G.O.	G.O.
H	500	550	590	840	970	1250	1350	1580	1900	2050	2200	2500
H1	550	620	690	990	1170	1500	1650	1930	2300	2600	2700	3100

FIG. N. P54 - PRESSURE SEAL GATE VALVES ASME CLASS 1500

SIZE	2"	3"	4"	6"	8"	10"	12"	14"	16"	18"	20"	24"
L RF	368	470	546	705	832	991	1130	1257	1384	1537	1664	1943
L RTJ	371	473	549	711	842	1000	1146	1276	1407	1559	1686	1972
L BW	216	305	406	559	711	864	991	1067	1194	1346	1473	1943
V	250	400	600	G.O.	G.O.	G.O.	G.O.	G.O.	G.O.	G.O.	G.O.	G.O.
H	500	550	590	840	970	1250	1350	1780	2000	2200	2400	2600
H1	550	630	690	990	1170	1500	1700	2130	2400	2650	2900	3200

FIG. N. P55 - PRESSURE SEAL GATE VALVES ASME CLASS 2500

SIZE	2"	3"	4"	6"	8"	10"	12"	14"	16"	18"	20"	24"
L RF	451	578	673	914	1022	1270	1422	-	-	-	-	-
L RTJ	454	584	683	927	1038	1292	1445	-	-	-	-	-
L BW	279	368	457	610	762	914	1041	1118	1245	1397	1524	1676
V	300	500	700	G.O.	G.O.	G.O.	G.O.	G.O.	G.O.	G.O.	G.O.	G.O.
H	500	550	600	860	1000	1330	1480	1860	2090	2350	2650	2800
H1	550	630	690	1010	1200	1580	1780	2210	2490	2800	3150	3400

features on request

- | | |
|--|--|
| <ul style="list-style-type: none"> <input type="radio"/> TOP FLANGE TO ISO 5210 <input type="radio"/> GEAR OPERATOR <input type="radio"/> CHAIN WHEEL OPERATOR <input type="radio"/> PNEUMATIC OR HYDRAULIC ACTUATOR <input type="radio"/> ELECTRIC ACTUATOR <input type="radio"/> POSITION INDICATOR <input type="radio"/> LIMIT SWITCHES <input type="radio"/> LOCKING / INTERLOCK SYSTEM <input type="radio"/> PTFE SOFT SEATS <input type="radio"/> PARALLEL WEDGE | <ul style="list-style-type: none"> <input type="radio"/> TWO PIECE BODY GUIDED WEDGE <input type="radio"/> STEM PROTECTION <input type="radio"/> STEM EXTENSION <input type="radio"/> LANTERN RING <input type="radio"/> EXTENDED STUFFING BOX <input type="radio"/> LIVE LOADED PACKING <input type="radio"/> DRAIN PLUG <input type="radio"/> BY PASS <input type="radio"/> FLANGED ENDS <input type="radio"/> DIN CONNECTIONS |
|--|--|

All dimensions in mm (except where differently indicated)

All data, subject to technical changes, are only for information and not for official use.

VALVOSIDER s.r.l. - Via S. Rocco, 2 - P.O. BOX 76 - 13011 Borgosesia (VC) - Italy
Phone: +39016322991 - Fax: +39016321537 - www.valvosider.com - e-mail: valvo@valvosider.com

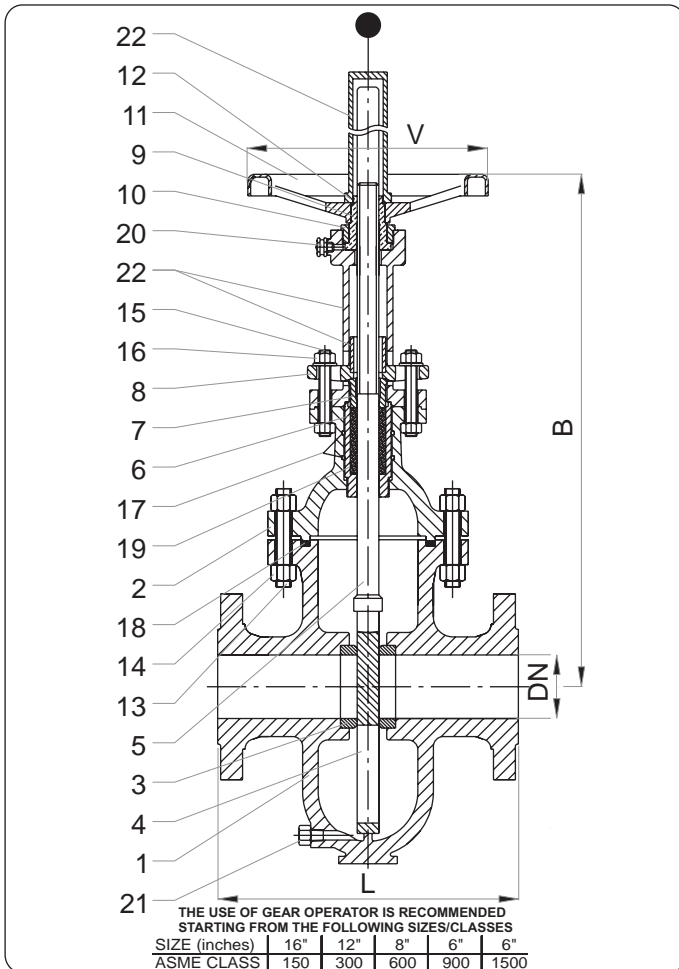

standard features

- **Description** ROUND OR FLAT BODY
BOLTED BONNET
OUTSIDE SCREW AND YOKE
RISING STEM
NON RISING HANDWHEEL
RENEWABLE SOFT SEATS
PARALLEL SLAB GATE
- **Design** API 6 D
ASME B16.34
ASME B31.3
- **Face to face** API 6D
- **Flanges** ASME B16.5 FROM 2" TO 24"
ASME B16.47 FROM ≥ 26"
BW ENDS TO ASME B16.25
- **Testing** API 598
API 6D
BS 6755
- **Rating** ASME B16.34
- **Marking** API 6D
MSS-SP 25
CE - PED
- **Certificates** EN 10204 - 3.1 B

PART NAME	WT5x	LCT5x
1 Body	A216 WCB	A352 LCC
2 Bonnet	A216 WCB	A352 LCC
3 Seat ring surface	A105 (1)	A350 LF2 (1)
4 Gate seat surfaces	A516 Gr70(2)	A537 CL1 (2)
5 Stem	AISI 410 (3)	AISI 410 (3)
6 Stuffing box	A105 (3)	A350 LF2 (3)
7 Gland	A105 (3)	A350 LF2 (3)
8 Gland flange	A105	A350 LF2
9 Yoke sleeve	B148 9A (4)	B148 9A (4)
10 Yoke nut	A105	A105
11 Handwheel	Steel	Steel
12 Handwheel nut	A105	A105
13 Bolts	B7	L7
14 Nuts	2H	G4
15 Eye bolts	B7	L7
16 Nuts	2H	G4
17 O rings	BUNA	BUNA / VITON
18 Gasket	BUNA (5)	BUNA / VITON (5)
19 Packing	VITON (6)	VITON (6)
20 Grease nipple	A105	A105
21 Plug	A105	A350 LF2
22 Stem protection	A105	A105

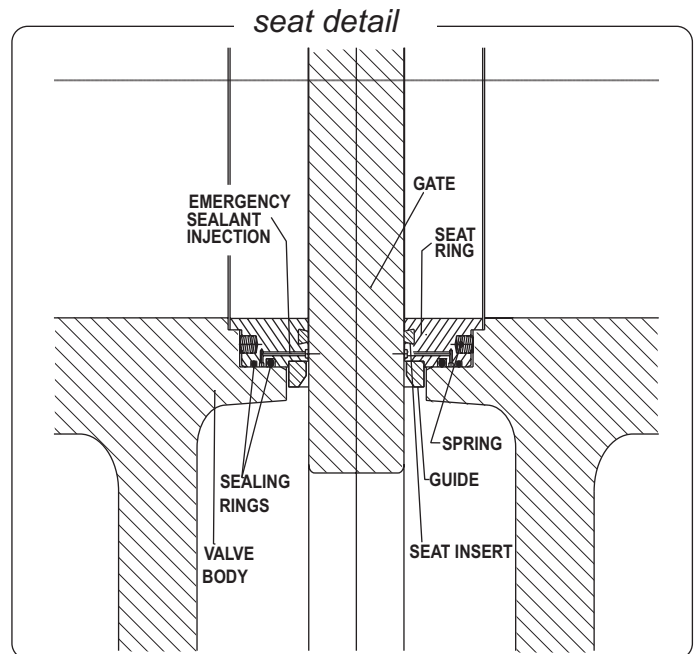

- (1) On request: faced with Stellite® - Monel® - Hastelloy® - other materials
- (2) On request: faced with Stellite® - Monel® - Hastelloy® - other materials
- (3) On request: 17 Cr - Monel® - Hastelloy® - other materials

- (4) On request: Nodular Iron - Nitronic 60
- (5) On request: Graphite - other materials
- (6) On request: Graphite - other materials

All data, subject to technical changes, are only for information and not for official use.

GATE VALVES - THROUGH CONDUIT ASME 150 - 300 - 600 - 900 - 1500

VALVOSIDER
MANUFACTURER OF VALVES

FIG. N. T50 - THROUGH CONDUIT GATE VALVES OVAL BODY ASME CLASS 150

SIZE	3"	4"	6"	8"	10"	12"	14"	16"	18"	20"	22"	24"	26"	28"	30"	32"	34"	36"	40"	42"	48"
L RF	203	229	267	292	330	356	381	406	432	457	508	508	559	610	650	711	762	800	914	--	--
L BW	282	305	403	419	457	502	572	610	660	711	762	813	864	914	914	965	1016	1016	1118	--	--
DN	76	102	152	203	254	305	337	387	439	489	540	591	635	686	737	782	831	876	927	--	--
V	300	300	300	450	600	600	600	600	600	800	G.O.	G.O.	G.O.	G.O.	G.O.	G.O.	G.O.	G.O.	G.O.	--	--
A	215	270	345	433	520	584	630	722	785	860	974	1050	1160	1210	1295	1360	1480	1540	1700	--	--
B	505	530	665	820	975	1100	1190	1345	1480	1610	1800	1880	2110	2190	2330	2530	2660	2800	3160	--	--

FIG. N. T51 - THROUGH CONDUIT GATE VALVES ASME CLASS 300

SIZE	3"	4"	6"	8"	10"	12"	14"	16"	18"	20"	22"	24"	26"	28"	30"	32"	34"	36"	40"	42"	48"
L RF/BW	282	305	403	419	457	502	762	838	914	991	1092	1143	1245	1346	1397	1524	1626	1727	1930	--	--
L RTJ	298	321	419	435	473	518	778	854	930	1010	1114	1165	1270	1372	1422	1552	1654	1755	--	--	--
DN	76	102	152	203	254	305	337	389	439	489	540	591	635	686	737	782	831	876	978	--	--
V	300	300	300	300	600	600	600	800	800	1100	G.O.	G.O.	G.O.	G.O.	G.O.	G.O.	G.O.	G.O.	G.O.	--	--
A	260	299	355	430	507	580	661	747	817	897	982	1037	1142	1252	1335	1395	1490	1570	1700	--	--
B	490	533	655	920	980	1110	1200	1360	1480	1650	1810	1930	2160	2230	2400	2570	2710	2820	3200	--	--

FIG. N. T52 - THROUGH CONDUIT GATE VALVES ASME CLASS 600

SIZE	3"	4"	6"	8"	10"	12"	14"	16"	18"	20"	22"	24"	26"	28"	30"	32"	34"	36"	40"	42"	48"
L RF/BW	356	432	559	660	787	838	889	991	1092	1194	1295	1397	1448	1549	1651	1778	1930	2083	2286	--	--
L RTJ	359	435	562	663	791	841	892	994	1095	1200	1305	1407	1461	1562	1664	1794	1946	2099	--	--	--
DN	76	102	152	203	254	305	337	389	439	489	540	591	635	686	737	782	831	876	978	--	--
V	300	300	300	300	600	600	600	800	800	1100	G.O.	G.O.	G.O.	G.O.	G.O.	G.O.	G.O.	G.O.	G.O.	--	--
A	212	307	405	435	510	590	630	725	810	930	995	1085	1170	1280	1350	1400	1490	1580	1710	--	--
B	485	530	690	860	980	1160	1200	1375	1500	1700	1900	2100	2200	2300	2400	2650	2750	2900	3200	--	--

FIG. N. T53 - THROUGH CONDUIT GATE VALVES ASME CLASS 900

SIZE	3"	4"	6"	8"	10"	12"	14"	16"	18"	20"	22"	24"	26"
L RF/BW	381	457	610	737	838	965	1029	1130	1219	1321	--	1549	--
L RTJ	384	460	613	740	841	968	1038	1140	1232	1334	--	1568	--
DN	76	102	152	203	254	305	337	389	439	489	540	591	--
V	300	300	300	300	600	600	G.O.	G.O.	G.O.	G.O.	G.O.	G.O.	--
A	207	252	337	422	514	590	637	727	917	987	--	1212	--
B	515	541	660	850	998	1200	1300	1400	1600	1800	--	2100	--

FIG. N. T54 - THROUGH CONDUIT GATE VALVES ASME CLASS 1500

SIZE	3"	4"	6"	8"	10"	12"	14"	16"	18"	20"	22"	24"	26"
L RF/BW	470	546	705	832	991	1130	1257	1384	1537	1664	--	1943	--
L RTJ	500	549	711	841	1000	1146	1276	1407	1559	1686	--	1972	--
DN	76	102	152	203	254	305	337	389	439	489	540	591	--
V	300	300	300	300	600	600	G.O.	G.O.	G.O.	G.O.	G.O.	G.O.	--
A	254	271	357	437	520	532	661	747	817	897	--	1037	--
B	588	661	715	860	1010	1200	1400	1500	1600	1800	--	2200	--

features on request

- TOP FLANGE TO ISO 5210
- GEAR OPERATOR
- CHAIN WHEEL OPERATOR
- PNEUMATIC ACTUATOR
- HYDRAULIC ACTUATOR
- ELECTRIC ACTUATOR
- POSITION INDICATOR
- LIMIT SWITCHES
- LOCKING / INTERLOCK SYSTEM
- PTFE SOFT SEATS
- STEM PROTECTION
- STEM EXTENSION
- SECONDARY SEAL
- LANTERN RING
- EXTENDED STUFFING BOX
- LIVE LOADED PACKING
- DRAIN PLUG
- BY PASS
- BW ENDS
- DIN CONNECTIONS

All dimensions in mm (except where differently indicated)

All data, subject to technical changes, are only for information and not for official use.

VALVOSIDER s.r.l. - Via S. Rocco, 2 - P.O. BOX 76 - 13011 Borgosesia (VC) - Italy
Phone: +39016322991 - Fax: +39016321537 - www.valvosider.com - e-mail: valvo@valvosider.com

DESCRIPTION OF A TYPICAL GATE VALVE - BELLOW SEAL

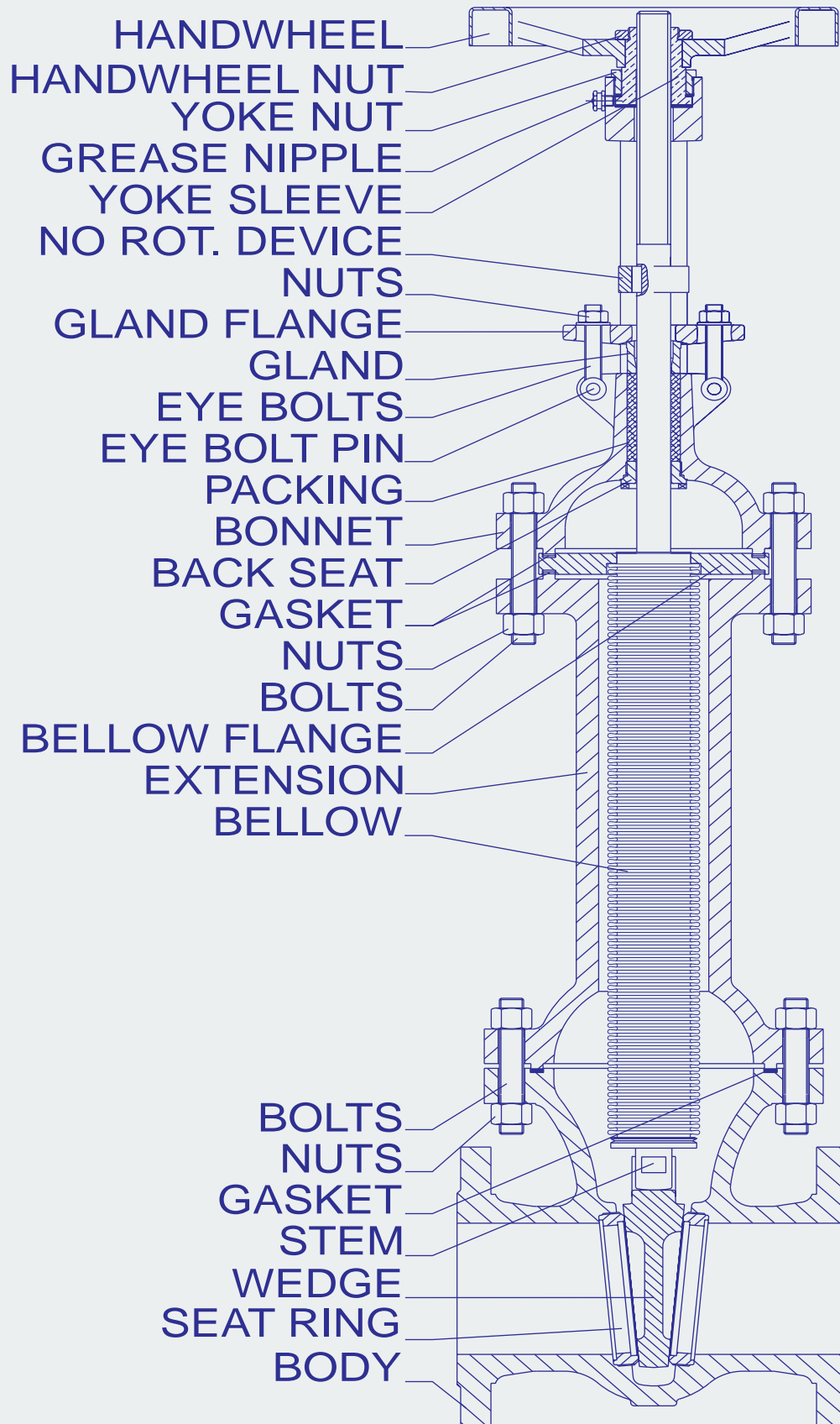

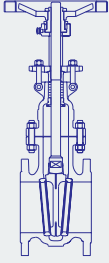
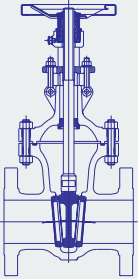
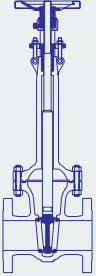
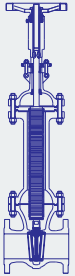
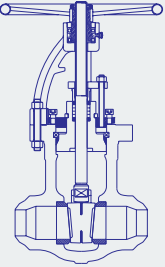
	TYPE	CLASS	SIZES	FIG. N
	GATE VALVES BOLTED BONNET OVAL TYPE	PN 16 - F4	50 - 900	1180
		PN 16 - F5	50 - 1400	1190
<p style="text-align: right;">page 60</p>				
	GATE VALVES BOLTED BONNET ROUND TYPE	PN 16	50 - 1400	1200
		PN 25	50 - 1400	1210
		PN 40	50 - 1000	1220
		PN 63	50 - 600	1230
		PN 100	50 - 600	1240
		PN 160	50 - 400	1250
<p style="text-align: right;">page 62</p>				
	GATE VALVES CRYOGENIC EXTENDED BONNET	PN 16	50 - 600	1200EB
		PN 25	50 - 600	1210EB
		PN 40	50 - 600	1220EB
		PN 63	50 - 600	1230EB
		PN 100	50 - 600	1240EB
<p style="text-align: right;">page 64</p>				
	GATE VALVES BELLOW SEAL	PN 16	50 - 600	1200SO
		PN 25	50 - 600	1210SO
		PN 40	50 - 600	1220SO
		PN 63	50 - 600	1230SO
		PN 100	50 - 600	1240SO
<p style="text-align: right;">page 66</p>				
	GATE VALVES PRESSURE SEAL	PN 100	50 - 600	P24
		PN 160	50 - 600	P25
		PN 250	50 - 600	P26
		PN 320	50 - 600	P27
		PN 420	50 - 600	P28
<p style="text-align: right;">page 68</p>				

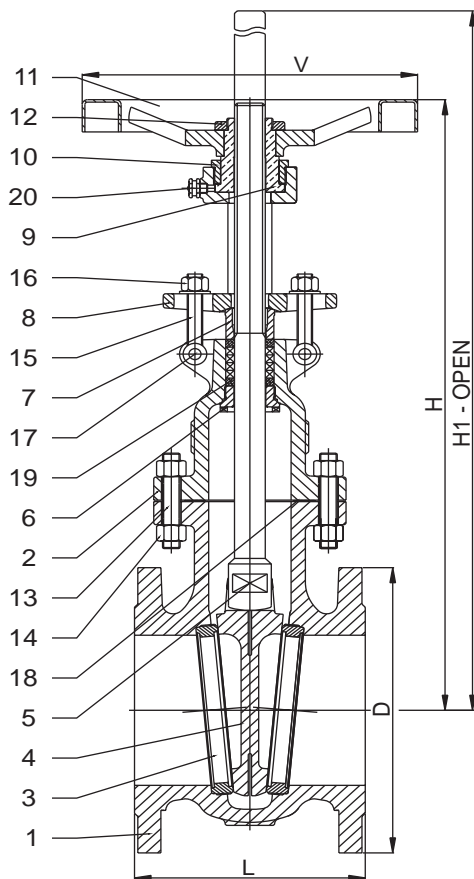

FIG. 1180 - DIN PN 16: Face to Face F4

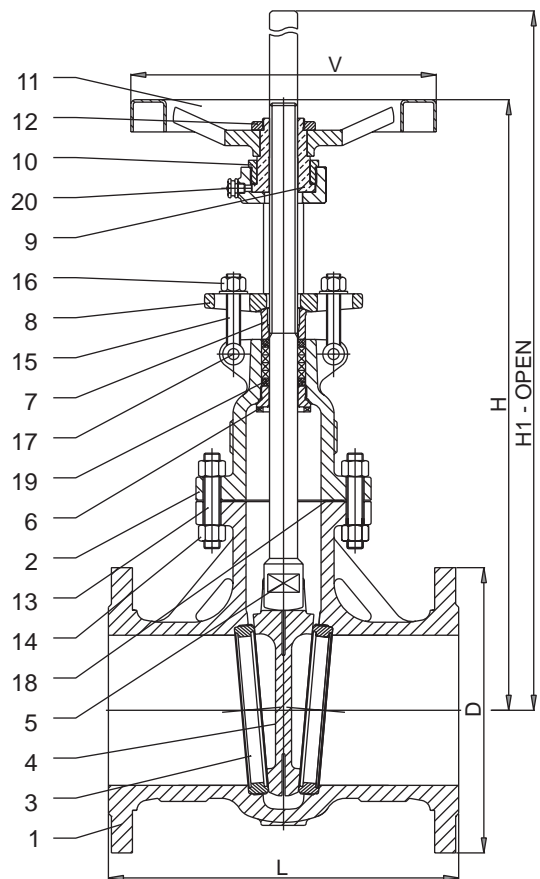

FIG. 1190 - DIN PN 16: Face to Face F5

PART NAME	A1180 - A1190	C1180 - C1190	FH1180 - FH1190	FK1180 - FK1190
1 Body	1.0619	1.7365	1.4552	1.4581
2 Bonnet	1.0619	1.7365	1.4552	1.4581
3 Seat ring surface	X20Cr13 (1)	X20Cr13 + HF (1)	X6CrNiTi18-10 (1)	X5CrNiMo17-12-2 (1)
4 Wedge seat surfaces	X20Cr13 (2)	X20Cr13 + HF (2)	X6CrNiTi18-10 (2)	X5CrNiMo17-12-2 (2)
5 Stem	X20Cr13 (3)	X20Cr13 (3)	X6CrNiTi18-10 (3)	X5CrNiMo17-12-2 (3)
6 Back seat	X20Cr13 (3)	X20Cr13 (3)	X6CrNiTi18-10 (3)	X5CrNiMo17-12-2 (3)
7 Gland	X20Cr13 (3)	X20Cr13 (3)	X6CrNiTi18-10 (3)	X5CrNiMo17-12-2 (3)
8 Gland flange	1.0460	X5CrNiMo17-12-2	X6CrNiTi18-10	X5CrNiMo17-12-2
9 Yoke sleeve	MS58 (4)	MS58 (4)	MS58 (4)	MS58 (4)
10 Yoke nut	1.0460	1.0460	X6CrNiTi18-10	X5CrNiMo17-12-2
11 Handwheel (*)		← Steel →		
12 Handwheel nut	1.0460	1.0460	X6CrNiTi18-10	X5CrNiMo17-12-2
13 Bolts	CK35	21CrMoV57	A2-70	A2-70
14 Nuts	C35	24CrMo5	A2-70	A2-70
15 Eye bolts	CK35	24CrMo5	A2-70	A2-70
16 Nuts	C35	24CrMo5	A2-70	A2-70
17 Eye bolt pin	CK35	24CrMo5	A2-70	A2-70
18 Gasket		← S.S. reinforced graphite (5) →		
19 Packing		← Graphite rings & wiper rings (6) →		
20 Grease nipple		← Steel →		

(1) On request: faced with Stellite® - Monel® - Hastelloy® - other materials

(2) On request: faced with Stellite® - Monel® - Hastelloy® - other materials

(3) On request: 17 Cr - Monel® - Hastelloy® - other materials

(*) Gear operator recommended from DN 500.

(4) On request: GGG50 - Nitronic 60

(5) On request: PTFE - other materials

(6) On request: PTFE - other materials

All data, subject to technical changes, are only for information and not for official use.

GATE VALVES OVAL BODY

DIN PN 16 - F4 - DIN PN 16 - F5

VALVOSIDER
MANUFACTURER OF VALVES

FIG. N. 1180 - GATE VALVES OVAL BODY DIN PN 16 - Face to Face F4

SIZE DN	50	65	80	100	125	150	200	250	300	350	400	500	600	700	800	900	--	--	--	--
L RF/BW	150	170	180	190	200	210	230	250	270	290	310	350	390	430	470	510	--	--	--	--
D	165	185	200	220	250	285	340	405	460	520	580	715	840	910	1025	1125	--	--	--	--
V	200	200	225	250	280	300	400	500	500	600	600	600	600	1000	1200	1200	--	--	--	--
H	350	420	500	520	610	700	900	1050	1200	1400	1580	1900	2300	2600	3200	4400	--	--	--	--
H1	415	495	580	620	720	840	1100	1300	1540	1750	1980	2450	3000	3500	4100	5500	--	--	--	--

FIG. N. 1190 - GATE VALVES OVAL BODY DIN PN 16 - Face to Face F5

SIZE DN	50	65	80	100	125	150	200	250	300	350	400	450	500	600	700	800	900	1000	1200	1400
L RF/BW	250	270	280	300	325	350	400	450	500	550	600	650	700	800	900	1000	1100	1200	1400	1600
D	165	185	200	220	250	285	340	405	460	520	580	640	715	840	910	1025	1125	1255	1485	1685
V	200	200	225	250	280	300	400	500	500	600	600	600	600	600	1000	1200	1200	1200	1400	1400
H	350	430	500	520	610	700	900	1050	1200	1400	1580	1750	1900	2300	2600	3200	4400	4700	5200	6200
H1	415	495	580	620	720	840	1100	1300	1540	1750	1980	2200	2450	3000	3500	4100	5500	5900	6600	7900

standard features

- Description** OVAL BODY
BOLTED BONNET
OUTSIDE SCREW AND YOKE
RISING STEM
NON RISING HANDWHEEL
FLEXIBLE WEDGE
RENEWABLE SEATS
- Design** DIN 3352
DIN 3840
- Face to face** DIN 3202
- Flanges** DIN 2501
DIN 2543
DIN 2526 FORM E
BW TO DIN 3239
- Testing** DIN 3352 Part 1
DIN 3230 Part 3
- Rating** DIN 2401
- Marking** EN 19
CE - PED
- Certificates** EN 10204 – 3.1 B

features on request

- TOP FLANGE TO ISO 5210
- GEAR OPERATOR
- CHAIN WHEEL OPERATOR
- PNEUMATIC ACTUATOR
- HYDRAULIC ACTUATOR
- ELECTRIC ACTUATOR
- POSITION INDICATOR
- LIMIT SWITCHES
- LOCKING / INTERLOCK SYSTEM
- PTFE SOFT SEATS
- STEM PROTECTION
- STEM EXTENSION
- LANTERN RING
- EXTENDED STUFFING BOX
- LIVE LOADED PACKING
- DRAIN PLUG
- BY PASS
- BW ENDS
- ANSI CONNECTIONS

All dimensions in mm (except where differently indicated)

All data, subject to technical changes, are only for information and not for official use.

VALVOSIDER s.r.l. - Via S. Rocco, 2 - P.O. BOX 76 - 13011 Borgosesia (VC) - Italy
Phone: +39016322991 - Fax: +39016321537 - www.valvosider.com - e-mail: valvo@valvosider.com

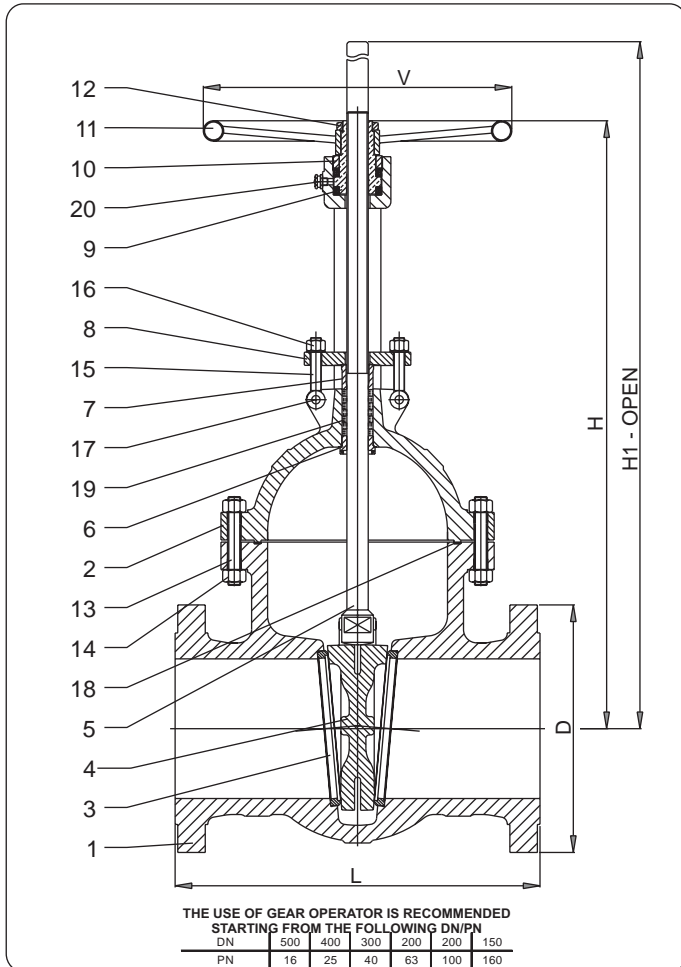

standard features

- **Description** ROUND BODY
BOLTED BONNET
OUTSIDE SCREW AND YOKE
RISING STEM
NON RISING HANDWHEEL
FLEXIBLE WEDGE
RENEWABLE SEATS
- **Design** DIN 3352
DIN 3840
- **Face to face** DIN 3202
- **Flanges** DIN 2501
DIN 2547
DIN 2526 FORM E
BW TO DIN 3239
- **Testing** DIN 3352 Part 1
DIN 3230 Part 3
- **Rating** DIN 2401
- **Marking** EN 19
CE - PED
- **Certificates** EN 10204 – 3.1 B

PART NAME	A12xx	C12xx	FH12xx	FK12xx
1 Body	1.0619	1.7365	1.4552	1.4581
2 Bonnet	1.0619	1.7365	1.4552	1.4581
3 Seat ring surface	X20Cr13 (1)	X20Cr13 + HF (1)	X6CrNiTi18-10 (1)	X5CrNiMo17-12-2 (1)
4 Wedge seat surfaces	X20Cr13 (2)	X20Cr13 + HF (2)	X6CrNiTi18-10 (2)	X5CrNiMo17-12-2 (2)
5 Stem	X20Cr13 (3)	X20Cr13 (3)	X6CrNiTi18-10 (3)	X5CrNiMo17-12-2 (3)
6 Back seat	X20Cr13 (3)	X20Cr13 (3)	X6CrNiTi18-10 (3)	X5CrNiMo17-12-2 (3)
7 Gland	X20Cr13 (3)	X20Cr13 (3)	X6CrNiTi18-10 (3)	X5CrNiMo17-12-2 (3)
8 Gland flange	1.0460	X5CrNiMo17-12-2	X6CrNiTi18-10	X5CrNiMo17-12-2
9 Yoke sleeve	MS58 (4)	MS58 (4)	MS58 (4)	MS58 (4)
10 Yoke nut	1.0460	1.0460	X6CrNiTi18-10	X5CrNiMo17-12-2
11 Handwheel			← Steel →	
12 Handwheel nut	1.0460	1.0460	X6CrNiTi18-10	X5CrNiMo17-12-2
13 Bolts	CK35	21CrMoV57	A2-70	A2-70
14 Nuts	C35	24CrMo5	A2-70	A2-70
15 Eye bolts	CK35	24CrMo5	A2-70	A2-70
16 Nuts	C35	24CrMo5	A2-70	A2-70
17 Eye bolt pin	CK35	24CrMo5	A2-70	A2-70
18 Gasket		← S.S. Reinforced graphite (5) →		
19 Packing		← Graphite rings & wiper rings (6) →		
20 Grease nipple		← Steel →		

(1) On request: faced with Stellite® - Monel® - Hastelloy® - other materials
 (2) On request: faced with Stellite® - Monel® - Hastelloy® - other materials
 (3) On request: 17 Cr - Monel® - Hastelloy® - other materials

(4) On request: GGG50 - Nitronic 60
 (5) On request: PTFE - other materials
 (6) On request: PTFE - other materials

All data, subject to technical changes, are only for information and not for official use.

GATE VALVES ROUND BODY

DIN PN 16 - 25 - 40 - 63 - 100 - 160

VALVOSIDER
MANUFACTURER OF VALVES

FIG. N. 1200 - GATE VALVES DIN PN 16 - Face to Face F5

SIZE DN	50	65	80	100	125	150	200	250	300	350	400	450	500	600	700	800	900	1000	1200	1400
L RF/BW	250	270	280	300	325	350	400	450	500	550	600	650	700	800	900	1000	1100	1200	1400	1600
D	165	185	200	220	250	285	340	405	460	520	580	640	715	840	910	1025	1125	1255	1485	1685
V	200	200	225	250	280	300	400	500	500	600	600	600	600	600	1000	1200	1200	1200	1400	1400
H	400	420	500	520	610	620	780	1050	1200	1400	1580	1750	1900	2300	2600	3200	4400	4700	5200	6200
H1	470	495	580	620	720	760	980	1300	1540	1750	1980	2200	2450	3000	3500	4100	5500	5900	6600	7900

FIG. N. 1210 - GATE VALVES DIN PN 25 - Face to Face F5

SIZE DN	50	65	80	100	125	150	200	250	300	350	400	450	500	600	700	800	900	1000	1200	1400
L RF/BW	250	270	280	300	325	350	400	450	500	550	600	650	700	800	900	1000	1100	1200	1400	1600
D	165	185	200	235	270	300	360	425	485	555	620	670	730	845	960	1085	1185	1320	1530	1755
V	200	200	225	250	280	300	400	500	500	600	600	600	600	600	1000	1200	1200	1200	1400	1400
H	400	430	500	520	610	700	900	1050	1200	1400	1580	1750	1900	2300	2600	3200	4400	4700	5200	6200
H1	470	495	580	620	720	840	1100	1300	1540	1750	1980	2200	2450	3000	3500	4100	5500	5900	6600	7900

FIG. N. 1220 - GATE VALVES DIN PN 40 - Face to Face F7

SIZE DN	50	65	80	100	125	150	200	250	300	350	400	450	500	600	700	800	900	1000	--	--
L RF/BW	250	290	310	350	400	450	550	650	750	850	950	1050	1150	1350	1550	1750	1950	2150	--	--
D	165	185	200	235	270	300	375	450	515	580	660	685	755	890	995	1140	1250	1360	--	--
V	200	200	225	250	300	400	500	500	600	700	700	800	1000	1200	1200	1400	1400	1400	--	--
H	400	430	500	520	610	700	900	1050	1200	1400	1580	1750	1900	2300	2600	3200	4400	4700	--	--
H1	470	495	580	620	720	840	1100	1300	1540	1750	1980	2200	2450	3000	3500	4100	5500	5900	--	--

FIG. N. 1230 - GATE VALVES DIN PN 63 - Face to Face F7

SIZE DN	50	65	80	100	125	150	200	250	300	350	400	500	600
L RF/BW	250	290	310	350	400	450	550	650	750	850	950	1150	1350
D	180	205	215	250	295	345	415	470	530	600	670	800	930
V	200	250	250	400	400	500	600	700	700	800	1000	1000	1200
H	450	500	540	670	685	810	970	1155	1330	1500	1680	2100	2400
H1	500	570	620	780	810	980	1180	1420	1660	1880	2100	2650	3100

FIG. N. 1240 - GATE VALVES DIN PN 100 - Face to Face F7

SIZE DN	50	65	80	100	125	150	200	250	300	350	400	500	600
L RF/BW	250	290	310	350	400	450	550	650	750	850	950	1150	1350
D	195	220	230	265	315	355	430	505	585	655	715	870	990
V	200	250	250	400	400	500	600	700	700	800	1000	1000	1200
H	450	500	540	670	685	810	970	1155	1330	1500	1680	2100	2400
H1	500	570	620	780	810	980	1180	1420	1660	1880	2100	2650	3100

FIG. N. 1250 - GATE VALVES DIN PN 160 - Face to Face F8

SIZE DN	50	65	80	100	125	150	200	250	300	350	400	--	--
L RF/BW	300	360	390	450	525	600	750	900	1050	1200	1350	--	--
D	195	220	230	265	315	355	430	505	585	655	715	--	--
V	200	250	250	400	400	500	600	700	700	800	1000	--	--
H	450	500	540	670	685	810	970	1155	1330	1500	1680	--	--
H1	500	570	620	780	810	980	1180	1420	1660	1880	2100	--	--

features on request

- TOP FLANGE TO ISO 5210
- GEAR OPERATOR
- CHAIN WHEEL OPERATOR
- PNEUMATIC ACTUATOR
- HYDRAULIC ACTUATOR
- ELECTRIC ACTUATOR
- POSITION INDICATOR
- LIMIT SWITCHES
- LOCKING / INTERLOCK
- PTFE SOFT SEATS
- STEM PROTECTION
- STEM EXTENSION
- LANTERN RING
- EXTENDED STUFFING BOX
- LIVE LOADED PACKING
- DRAIN PLUG
- BY PASS
- BW ENDS
- ANSI CONNECTIONS

All dimensions in mm (except where differently indicated)

All data, subject to technical changes, are only for information and not for official use.

VALVOSIDER s.r.l. - Via S. Rocco, 2 - P.O. BOX 76 - 13011 Borgosesia (VC) - Italy
Phone: +39016322991 - Fax: +39016321537 - www.valvosider.com - e-mail: valvo@valvosider.com

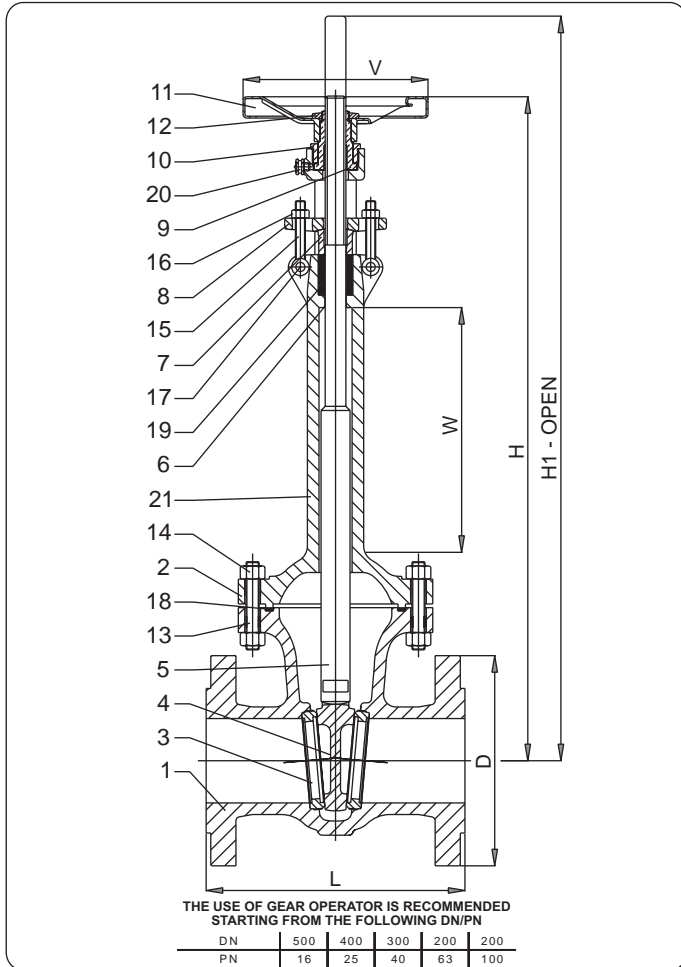

standard features

- **Description** EXTENDED BONNET
BOLTED BONNET
OUTSIDE SCREW AND YOKE
RISING STEM
NON RISING HANDWHEEL
RENEWABLE SEATS
- **Design** DIN 3352
DIN 3840
- **Face to face** DIN 3202
- **Flanges** DIN 2501
DIN 2547
DIN 2526 FORM E
BW TO DIN 3239
- **Testing** DIN 3352 Part 1
DIN 3230 Part 3
- **Rating** DIN 2401
- **Marking** EN 19
CE - PED
- **Certificates** EN 10204 – 3.1 B

PART NAME	FH12xxEB	FK12xxEB
1 Body	1.4552	1.4581
2 Bonnet	1.4552	1.4581
3 Seat ring surface	X6CrNiTi18-10 (1)	X5CrNiMo17-12-2 (1)
4 Wedge seat surfaces	X6CrNiTi18-10 (2)	X5CrNiMo17-12-2 (2)
5 Stem	X6CrNiTi18-10 (3)	X5CrNiMo17-12-2 (3)
6 Back seat (integral)	1.4552	1.4581
7 Gland	X6CrNiTi18-10 (3)	X5CrNiMo17-12-2 (3)
8 Gland flange	X6CrNiTi18-10	X5CrNiMo17-12-2
9 Yoke sleeve	MS58 (4)	MS58 (4)
10 Yoke nut	X6CrNiTi18-10	X5CrNiMo17-12-2
11 Handwheel	Steel	Steel
12 Handwheel nut	X6CrNiTi18-10	X5CrNiMo17-12-2
13 Bolts	A2-70	A2-70
14 Nuts	A2-70	A2-70
15 Eye bolts	A2-70	A2-70
16 Nuts	A2-70	A2-70
17 Eye bolt pin	A2-70	A2-70
18 Gasket	PTFE (5)	PTFE (5)
19 Packing	PTFE (6)	PTFE (6)
20 Grease nipple	1.4404	1.4404
21 Extension	X2CrNi19-11	X2CrNiMo17-12-2

- (1) On request: faced with Stellite® - Monel® - Hastelloy® - other materials
- (2) On request: faced with Stellite® - Monel® - Hastelloy® - other materials
- (3) On request: 17 Cr - Monel® - Hastelloy® - other materials

options

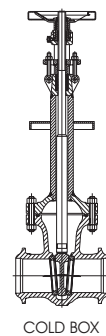
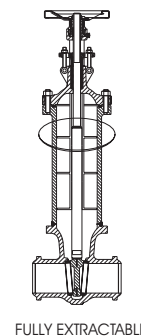
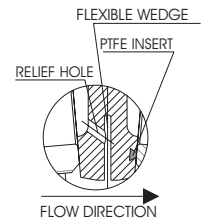
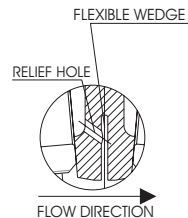

- (4) On request: GGG50 - Nitronic 60
- (5) On request: Graphite - other materials
- (6) On request: Graphite - other materials

All data, subject to technical changes, are only for information and not for official use.

CRYOGENIC GATE VALVES

DIN PN 16 - 25 - 40 - 63 - 100

VALVOSIDER
MANUFACTURER OF VALVES

FIG. N. 1200EB - CRYOGENIC GATE VALVES DIN PN 16 - F5

SIZE DN	50	65	80	100	125	150	200	250	300	350	400	450	500	600	700	800	900	1000	1200	1400
L RF/BW	250	270	280	300	325	350	400	450	500	550	600	650	700	800	--	--	--	--	--	--
D	165	185	200	220	250	285	340	405	460	520	580	640	715	840	--	--	--	--	--	--
V	200	200	225	250	280	300	400	500	500	600	600	600	600	600	--	--	--	--	--	--
W	200	200	300	300	300	300	300	300	300	300	300	300	300	300	--	--	--	--	--	--
H	600	630	800	820	910	920	1080	1350	1500	1700	1880	2050	2200	2600	--	--	--	--	--	--
H1	650	695	880	920	1020	1060	1280	1600	1840	2050	2280	2500	2750	3300	--	--	--	--	--	--

FIG. N. 1210EB - CRYOGENIC GATE VALVES DIN PN 25 - F5

SIZE DN	50	65	80	100	125	150	200	250	300	350	400	450	500	600	700	800	900	1000	1200	1400
L RF/BW	250	270	280	300	325	350	400	450	500	550	600	650	700	800	--	--	--	--	--	--
D	165	185	200	235	270	300	360	425	485	555	620	670	730	845	--	--	--	--	--	--
V	200	200	225	250	280	300	400	500	500	600	600	600	600	600	--	--	--	--	--	--
W	200	200	300	300	300	300	300	300	300	300	300	300	300	300	--	--	--	--	--	--
H	600	630	800	820	910	1000	1200	1350	1500	1700	1880	2050	2200	2600	--	--	--	--	--	--
H1	650	695	880	920	1020	1140	1400	1600	1840	2050	2280	2500	2750	3300	--	--	--	--	--	--

FIG. N. 1220EB - CRYOGENIC GATE VALVES DIN PN 40 - F7

SIZE DN	50	65	80	100	125	150	200	250	300	350	400	450	500	600	700	800	900	1000	1200	1400
L RF/BW	250	290	310	350	400	450	550	650	750	850	950	1050	1150	1350	--	--	--	--	--	--
D	165	185	200	235	270	300	375	450	515	580	660	685	755	890	--	--	--	--	--	--
V	200	200	225	250	280	300	400	500	500	600	600	600	600	600	--	--	--	--	--	--
W	200	200	300	300	300	300	300	300	300	300	300	300	300	300	--	--	--	--	--	--
H	600	630	800	820	910	1000	1200	1350	1500	1700	1880	2050	2200	2600	--	--	--	--	--	--
H1	650	695	880	920	1020	1140	1400	1600	1840	2050	2280	2500	2750	3300	--	--	--	--	--	--

FIG. N. 1230EB - CRYOGENIC GATE VALVES DIN PN 63 - F7

SIZE DN	50	65	80	100	125	150	200	250	300	350	400	500	600
L RF/BW	250	290	310	350	400	450	550	650	750	850	950	1150	1350
D	180	205	215	250	295	345	415	470	530	600	670	800	930
V	200	250	250	400	400	500	600	700	700	800	1000	1000	1200
W	200	200	300	300	300	300	300	300	300	300	300	300	300
H	650	700	840	970	985	1110	1270	1455	1630	1800	1980	2400	2700
H1	700	770	920	1080	1110	1280	1480	1720	1960	2180	2400	2950	3400

FIG. N. 1240EB - CRYOGENIC GATE VALVES DIN PN 100 - F7

SIZE DN	50	65	80	100	125	150	200	250	300	350	400	500	600
L RF/BW	250	290	310	350	400	450	550	650	750	850	950	1150	1350
D	195	220	230	265	315	355	430	505	585	655	715	870	990
V	200	250	250	400	400	500	600	700	700	800	1000	1000	1200
W	200	200	300	300	300	300	300	300	300	300	300	300	300
H	650	700	840	970	985	1110	1270	1455	1630	1800	1980	2400	2700
H1	700	770	920	1080	1110	1280	1480	1720	1960	2180	2400	2950	3400

features on request

- TOP FLANGE TO ISO 5210
- GEAR OPERATOR
- CHAIN WHEEL OPERATOR
- PNEUMATIC ACTUATOR
- HYDRAULIC ACTUATOR
- ELECTRIC ACTUATOR
- POSITION INDICATOR
- LIMIT SWITCHES
- LOCKING / INTERLOCK SYSTEM
- PTFE SOFT SEATS
- STEM PROTECTION
- STEM EXTENSION
- LANTERN RING
- EXTENDED STUFFING BOX
- LIVE LOADED PACKING
- DRAIN PLUG
- BY PASS
- BW ENDS
- ANSI CONNECTIONS

All dimensions in mm (except where differently indicated)

All data, subject to technical changes, are only for information and not for official use.

VALVOSIDER s.r.l. - Via S. Rocco, 2 - P.O. BOX 76 - 13011 Borgosesia (VC) - Italy
Phone: +39016322991 - Fax: +39016321537 - www.valvosider.com - e-mail: valvo@valvosider.com

standard features

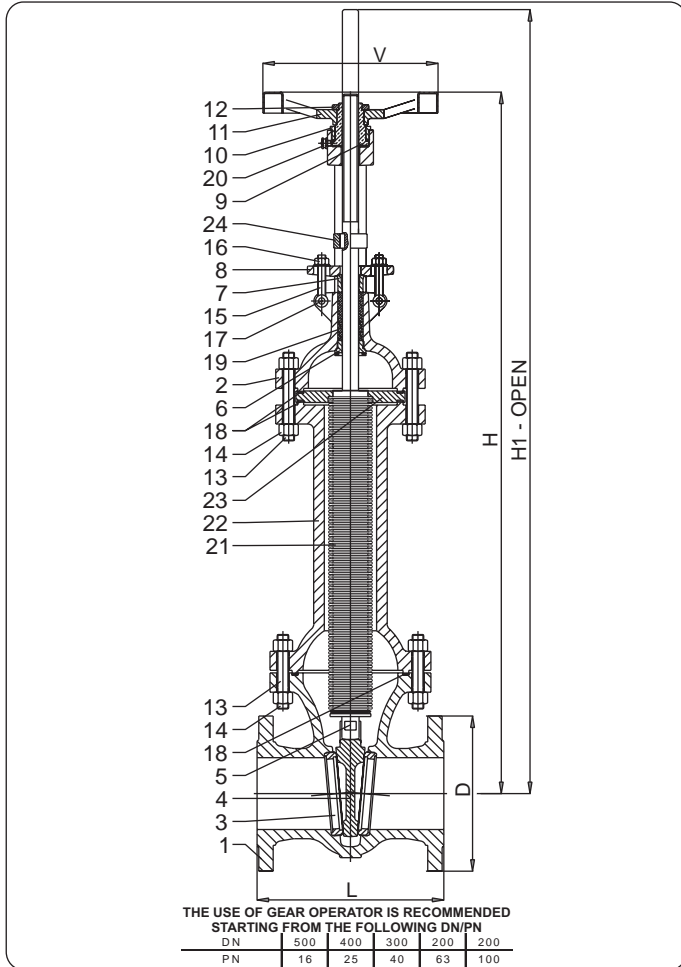

- **Description** EXTENDED BODY
BOLTED BONNET
OUTSIDE SCREW AND YOKE
RISING STEM
NON RISING HANDWHEEL
RENEWABLE SEATS
BELLOW SEAL
- **Design** DIN 3352
DIN 3840
- **Face to face** DIN 3202
- **Flanges** DIN 2501
DIN 2547
DIN 2526 FORM E
BW TO DIN 3239
- **Testing** DIN 3352 Part 1
DIN 3230 Part 3
- **Rating** DIN 2401
- **Marking** EN 19
CE - PED
- **Certificates** EN 10204 – 3.1 B

PART NAME	A12xxSO	C12xxSO	FH12xxSO	FK12xxSO
1 Body	1.0619	1.7365	1.4552	1.4581
2 Bonnet	1.0619	1.7365	1.4552	1.4581
3 Seat ring surface	X20Cr13 (1)	X20Cr13 + HF (1)	X6CrNiTi18-10 (1)	X5CrNiMo17-12-2 (1)
4 Wedge seat surfaces	X20Cr13 (2)	X20Cr13 + HF (2)	X6CrNiTi18-10 (2)	X5CrNiMo17-12-2 (2)
5 Stem	X20Cr13 (3)	X20Cr13 (3)	X6CrNiTi18-10 (3)	X5CrNiMo17-12-2 (3)
6 Back seat	X20Cr13 (3)	X20Cr13 (3)	X6CrNiTi18-10 (3)	X5CrNiMo17-12-2 (3)
7 Gland	X20Cr13 (3)	X20Cr13 (3)	X6CrNiTi18-10 (3)	X5CrNiMo17-12-2 (3)
8 Gland flange	1.0460	X5CrNiMo17-12-2	X6CrNiTi18-10	X5CrNiMo17-12-2
9 Yoke sleeve		←	MS58 (4)	→
10 Yoke nut	1.0460	1.0460	X6CrNiTi18-10	X5CrNiMo17-12-2
11 Handwheel		←	Steel	→
12 Handwheel nut	1.0460	1.0460	X6CrNiTi18-10	X5CrNiMo17-12-2
13 Bolts	CK35	21CrMoV57	A2-70	A2-70
14 Nuts	C35	24CrMo5	A2-70	A2-70
15 Eye bolts	CK35	24CrMo5	A2-70	A2-70
16 Nuts	C35	24CrMo5	A2-70	A2-70
17 Eye bolt pin	CK35	24CrMo5	A2-70	A2-70
18 Gasket		←	S.S. reinforced graphite (5)	→
19 Packing		←	Graphite rings & wiper rings (6)	→
20 Grease nipple		←	Steel	→
21 Bellow	X6CrNiTi18-10	X6CrNiTi18-10	X6CrNiTi18-10	X6CrNiTi18-10
22 Extension	1.0460	1.7363	X6CrNiNb18-10	X2CrNiMo17-12-2
23 Bellow flange		←	X6CrNiTi18-10	→
24 No rot. Device	X20Cr13	X20Cr13	X6CrNiTi18-10	X5CrNiMo17-12-2

(1) On request: faced with Stellite® - Monel® - Hastelloy® - other materials
 (2) On request: faced with Stellite® - Monel® - Hastelloy® - other materials
 (3) On request: 17 Cr - Monel® - Hastelloy® - other materials

(4) On request: GGG50 - Nitronic 60
 (5) On request: PTFE - other materials
 (6) On request: PTFE - other materials

All data, subject to technical changes, are only for information and not for official use.

GATE VALVES - BELLOW SEAL DIN PN 16 - 25 - 40 - 63 - 100

VALVOSIDER
MANUFACTURER OF VALVES

FIG. N. 1200SO - BELLOW GATE VALVES DIN PN 16 - F5

SIZE DN	50	65	80	100	125	150	200	250	300	350	400	450	500	600	700	800	900	1000	1200	1400
L RF/BW	250	270	280	300	325	350	400	450	500	550	600	650	700	800	--	--	--	--	--	--
D	165	185	200	220	250	285	340	405	460	520	580	640	715	840	--	--	--	--	--	--
V	200	200	225	250	280	300	400	500	500	600	600	600	600	600	--	--	--	--	--	--
H	610	675	820	940	1160	1530	1960	2530	2600	2980	3170	2550	4050	4650	--	--	--	--	--	--
H1	660	740	900	1040	1290	1680	2160	2600	2900	3350	3570	4000	4550	5250	--	--	--	--	--	--

FIG. N. 1210SO - BELLOW GATE VALVES DIN PN 25 - F5

SIZE DN	50	65	80	100	125	150	200	250	300	350	400	450	500	600	700	800	900	1000	1200	1400
L RF/BW	250	270	280	300	325	350	400	450	500	550	600	650	700	800	--	--	--	--	--	--
D	165	185	200	235	270	300	360	425	485	555	620	670	730	845	--	--	--	--	--	--
V	200	200	225	250	280	300	400	500	500	600	600	600	600	600	--	--	--	--	--	--
H	610	675	820	940	1160	1530	1960	2530	2600	2980	3170	2550	4050	4650	--	--	--	--	--	--
H1	660	740	900	1040	1290	1680	2160	2600	2900	3350	3570	4000	4550	5250	--	--	--	--	--	--

FIG. N. 1220SO - BELLOW GATE VALVES DIN PN 40 - F7

SIZE DN	50	65	80	100	125	150	200	250	300	350	400	450	500	600	700	800	900	1000	1200	1400
L RF/BW	250	290	310	350	400	450	550	650	750	850	950	1050	1150	1350	--	--	--	--	--	--
D	165	185	200	235	270	300	375	450	515	580	660	685	755	890	--	--	--	--	--	--
V	200	200	225	250	280	300	400	500	500	600	600	600	600	600	--	--	--	--	--	--
H	600	685	765	920	1070	1315	1700	2035	2395	2760	3135	3600	4080	4795	--	--	--	--	--	--
H1	650	750	840	1020	1200	1465	1900	2285	2700	3110	4535	4050	4580	5350	--	--	--	--	--	--

FIG. N. 1230SO - BELLOW GATE VALVES DIN PN 63 - F7

SIZE DN	50	65	80	100	125	150	200	250	300	350	400	500	600
L RF/BW	250	290	310	350	400	450	550	650	750	850	950	1150	1350
D	180	205	215	250	295	345	415	470	530	600	670	800	930
V	200	250	250	400	400	500	600	700	700	800	1000	1000	1200
H	650	685	805	905	1070	1360	1720	2120	2500	--	--	--	--
H1	700	750	880	1010	1200	1510	1920	2370	2800	--	--	--	--

FIG. N. 1240SO - BELLOW GATE VALVES DIN PN 100 - F7

SIZE DN	50	65	80	100	125	150	200	250	300	350	400	500	600
L RF/BW	250	290	310	350	400	450	550	650	750	850	950	1150	1350
D	195	220	230	265	315	355	430	505	585	655	715	870	990
V	200	250	250	400	400	500	600	700	700	800	1000	1000	1200
H	650	685	805	905	1070	1360	1720	2120	2500	--	--	--	--
H1	700	750	880	1010	1200	1510	1920	2370	2800	--	--	--	--

features on request

- TOP FLANGE TO ISO 5210
- GEAR OPERATOR
- CHAIN WHEEL OPERATOR
- PNEUMATIC ACTUATOR
- HYDRAULIC ACTUATOR
- ELECTRIC ACTUATOR
- POSITION INDICATOR
- LIMIT SWITCHES
- LOCKING / INTERLOCK SYSTEM
- PTFE SOFT SEATS
- STEM PROTECTION
- STEM EXTENSION
- LANTERN RING
- EXTENDED STUFFING BOX
- LIVE LOADED PACKING
- DRAIN PLUG
- BY PASS
- BW ENDS
- ANSI CONNECTIONS

All dimensions in mm (except where differently indicated)

All data, subject to technical changes, are only for information and not for official use.

VALVOSIDER s.r.l. - Via S. Rocco, 2 - P.O. BOX 76 - 13011 Borgosesia (VC) - Italy
Phone: +39016322991 - Fax: +39016321537 - www.valvosider.com - e-mail: valvo@valvosider.com

standard features

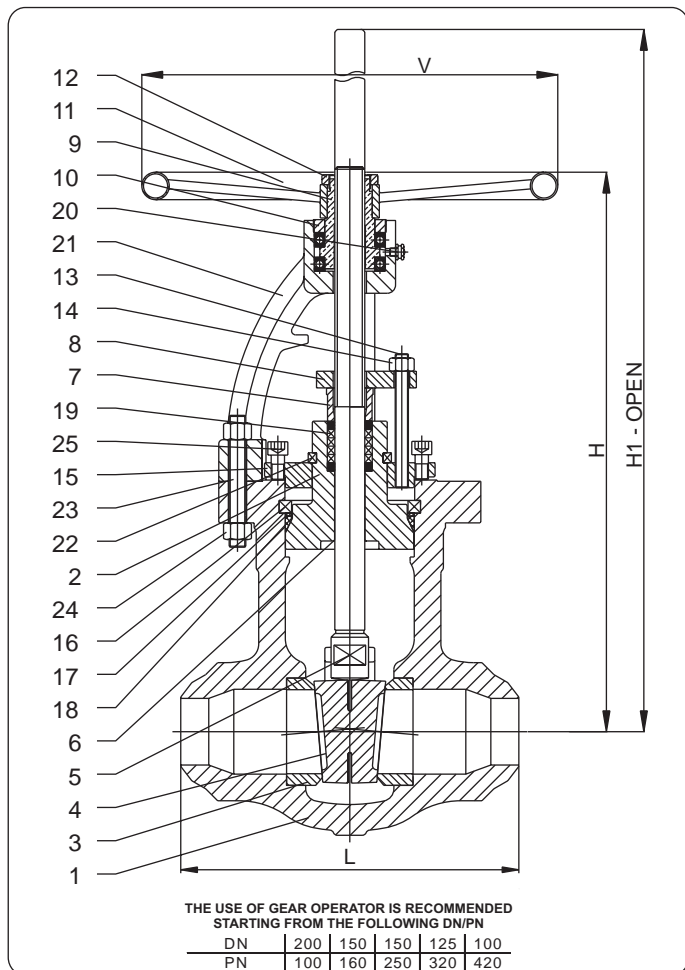

- **Description** ROUND BODY
PRESSURE SEAL BONNET
OUTSIDE SCREW AND YOKE
RISING STEM
NON RISING HANDWHEEL
INTEGRAL BACKSEAT
WELDED IN SEATS
FLEXIBLE WEDGE
- **Design** DIN 3352
DIN 3840
- **Face to face** DIN 3202
- **Flanges** DIN 2501
DIN 2547
DIN 2526 FORM E
BW TO DIN 3239
- **Testing** DIN 3352 Part 1
DIN 3230 Part 3
- **Rating** DIN 2401
- **Marking** EN 19
CE - PED
- **Certificates** EN 10204 – 3.1 B

PART NAME	AP2x	IP2x	MP2x	WCP2x	FKP2x
1 Body	1.0619	1.5419	1.7357	1.7379	1.4581
2 Bonnet	1.0619	1.5419	1.7357	1.7379	1.4581
3 Ring - seat surface	1.0160 + HF (1)	1.0160 + HF (1)	1.0460 + HF (1)	1.0160 + HF (1)	1.4401 + HF(1)
4 Wedge - seat surfaces	1.0619 + HF (1)	1.5419 + HF (1)	1.7357 + HF (1)	1.7380 + HF (1)	1.4581 + HF (1)
5 Stem	X20Cr13 (3)	X20Cr13 (3)	X20Cr13 (3)	X20Cr13 (3)	1.4401 (3)
6 Back seat (integral)		←	Stellite® (2)	→	
7 Gland	X20Cr13 (3)	X20Cr13 (3)	X20Cr13 (3)	X20Cr13 (3)	1.4401 (3)
8 Gland flange	1.0460	1.4401	1.4401	1.4401	1.4401
9 Yoke sleeve		←	GGG50 (4)	→	
10 Yoke nut	1.0460	1.0460	1.0460	1.0460	1.4401
11 Handwheel		←	Steel	→	
12 Handwheel nut		←	1.0460'	→	
13 Bolts	CK35	21CrMoV57	21CrMoV57	21CrMoV57	A2-70
14 Nuts	C35	24CrMo5	24CrMo5	24CrMo5	A2-70
15 Retainer flange	1.0160	1.0160	1.0460	1.0160	1.4401
16 Retainer ring	X20Cr13	X20Cr13	X20Cr13	X20Cr13	1.4401
17 Spacer ring	X20Cr13	X20Cr13	X20Cr13	X20Cr13	1.4401
18 Gasket		←	S. S. reinforced graphite (5)	→	
19 Packing		←	Graphite rings & wiper rings	→	
20 Grease nipple		←	Steel	→	
21 Yoke	1.0619	1.5419	1.7357	1.7380	1.4581
22 Segmented support ring	X20Cr13	X20Cr13	X20Cr13	X20Cr13	1.4401
23 Yoke / body bolt	CK35	21CrMoV57	21CrMoV57	21CrMoV57	A2-70
24 Yoke / body nut	C35	24CrMo5	24CrMo5	24CrMo5	A2-70
25 Bolt	CK35	21CrMoV57	21CrMoV57	21CrMoV57	A2-70

(1) On request: faced with Stellite® - Monel® - Hastelloy® - other materials
 (2) On request: faced with Monel® - Hastelloy® - other materials
 (3) On request: 17 Cr - Monel® - Hastelloy® - other materials

(4) On request: Other materials
 (5) On request: Metal

All data, subject to technical changes, are only for information and not for official use.

PRESSURE SEAL GATE VALVES DIN PN 100 - 160 - 250 - 320 - 420

VALVOSIDER
MANUFACTURER OF VALVES

FIG. P24 - PRESSURE SEAL GATE VALVES DIN PN 100 - F8

SIZE	50	65	80	100	125	150	200	250	300	350	400	500	600
L BW	300	360	390	450	525	600	750	900	1050	1200	1350	1650	--
V	200	200	250	300	400	400	500	G.O.	G.O.	G.O.	G.O.	G.O.	--
H	500	590	590	600	860	860	1000	1330	1480	--	--	--	--
H1	560	670	700	720	1010	1040	1240	1610	1820	--	--	--	--

FIG. P25 - PRESSURE SEAL GATE VALVES DIN PN 160 - F8

SIZE	50	65	80	100	125	150	200	250	300	350	400	500	600
L BW	300	360	390	450	525	600	750	900	1050	1200	1350	1650	--
V	200	200	250	300	400	400	500	G.O.	G.O.	G.O.	G.O.	G.O.	--
H	500	590	590	600	860	860	1000	1330	1480	--	--	--	--
H1	560	670	700	720	1010	1040	1240	1610	1820	--	--	--	--

FIG. P26 - PRESSURE SEAL GATE VALVES DIN PN 250 - F8

SIZE	50	65	80	100	125	150	200	250	300	350	400	500	600
L BW	300	360	390	450	525	600	750	900	1050	1200	1350	1650	--
V	200	200	250	300	400	400	500	G.O.	G.O.	G.O.	G.O.	G.O.	--
H	500	590	590	600	860	860	1000	1330	1480	--	--	--	--
H1	560	670	700	720	1010	1040	1240	1610	1820	--	--	--	--

FIG. P27 - PRESSURE SEAL GATE VALVES DIN PN 320 - F8

SIZE	50	65	80	100	125	150	200	250	300	350	400	500	600
L BW	300	360	390	450	525	600	750	900	1050	1200	1350	1650	--
V	200	200	250	300	400	400	500	G.O.	G.O.	G.O.	G.O.	G.O.	--
H	500	590	590	600	860	860	1000	1330	1480	--	--	--	--
H1	560	670	700	720	1010	1040	1240	1610	1820	--	--	--	--

FIG. P28 - PRESSURE SEAL GATE VALVES DIN PN 420 - F8

SIZE	50	65	80	100	125	150	200	250	300	350	400	500	600
L BW	300	360	390	450	525	600	750	900	1050	1200	1350	1650	--
V	200	200	250	300	400	400	500	G.O.	G.O.	G.O.	G.O.	G.O.	--
H	500	590	590	600	860	860	1000	1330	1480	--	--	--	--
H1	560	670	700	720	1010	1040	1240	1610	1820	--	--	--	--

features on request

- TOP FLANGE TO ISO 5210
- GEAR OPERATOR
- CHAIN WHEEL OPERATOR
- PNEUMATIC OR HYDRAULIC ACTUATOR
- ELECTRIC ACTUATOR
- POSITION INDICATOR
- LIMIT SWITCHES
- LOCKING / INTERLOCK SYSTEM
- PTFE SOFT SEATS
- PARALLEL WEDGE
- TWO PIECE BODY GUIDED WEDGE
- STEM PROTECTION
- STEM EXTENSION
- LANTERN RING
- EXTENDED STUFFING BOX
- LIVE LOADED PACKING
- DRAIN PLUG
- BY PASS
- FLANGED ENDS
- ANSI CONNECTIONS

All dimensions in mm (except where differently indicated)

All data, subject to technical changes, are only for information and not for official use.

VALVOSIDER s.r.l. - Via S. Rocco, 2 - P.O. BOX 76 - 13011 Borgosesia (VC) - Italy
Phone: +39016322991 - Fax: +39016321537 - www.valvosider.com - e-mail: valvo@valvosider.com

DESIGN AND MANUFACTURE OF VALVES *your partner in valves*



1 Special Executions

page 116

2 Dimensions

page 119

ASME

3 Materials & Trim

page 124

4 Ratings

page 125

5 Dimensions

page 128

DIN

6 Materials

page 132

7 Materials comparison

page 133

8 Ratings

page 134

9 Flow data

page 135

10 Tables

page 136

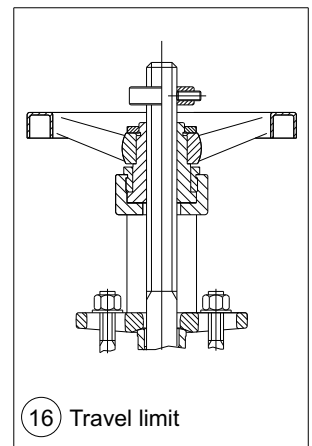
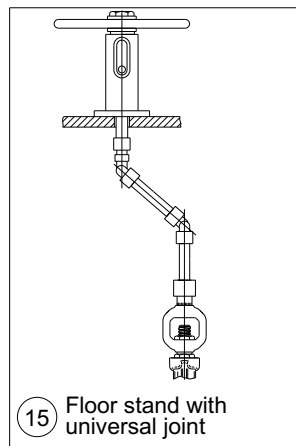
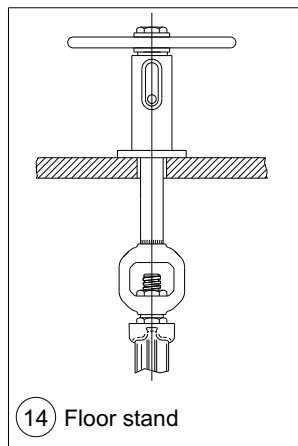
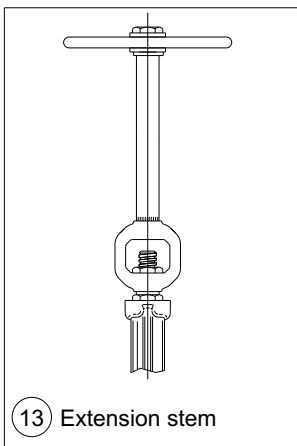
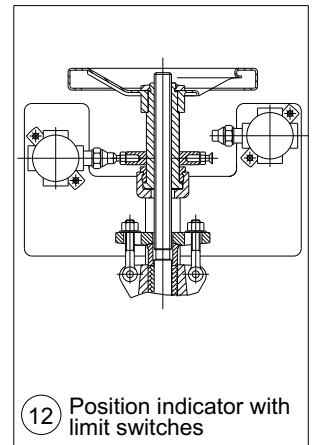
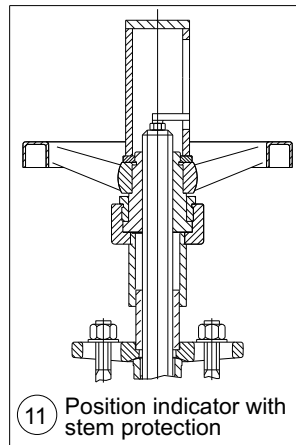
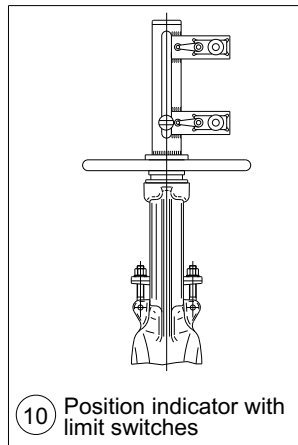
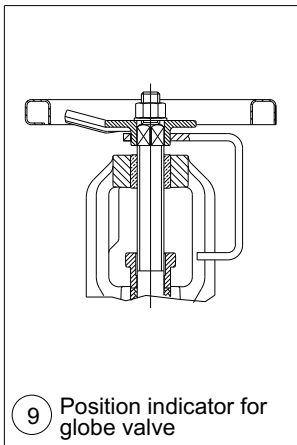
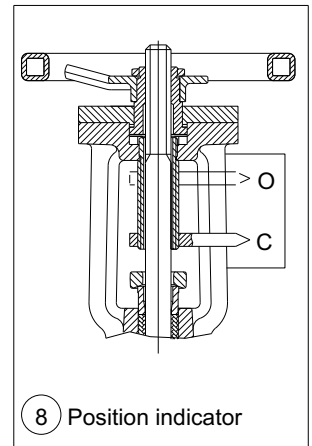
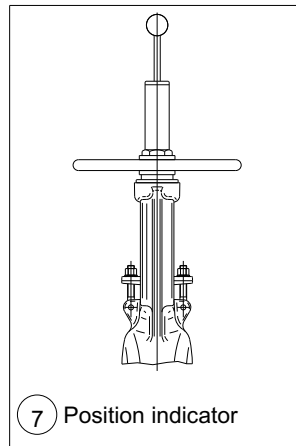
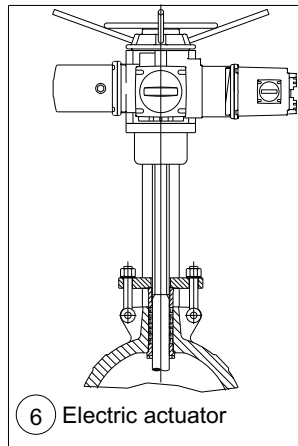
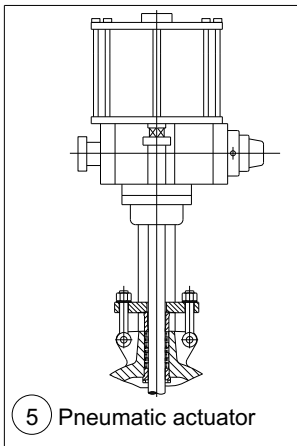
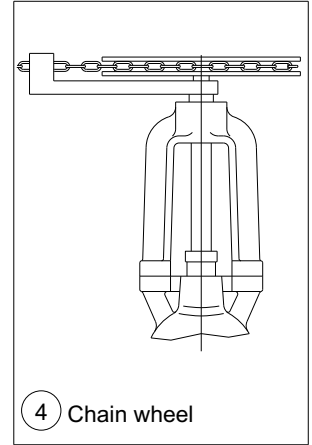
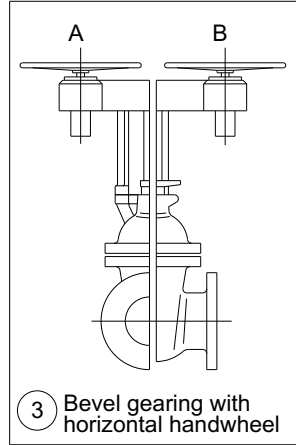
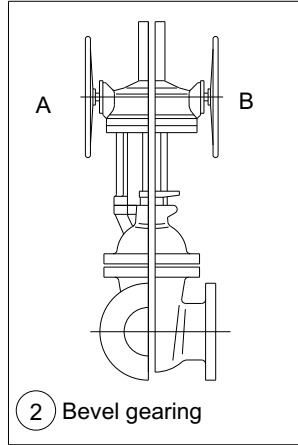
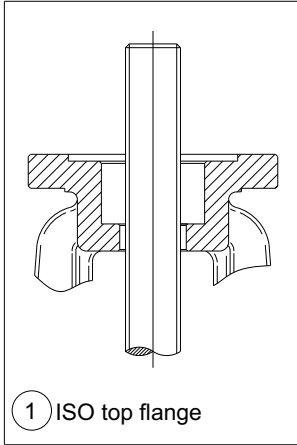

All data, subject to technical changes, are only for information and not for official use.

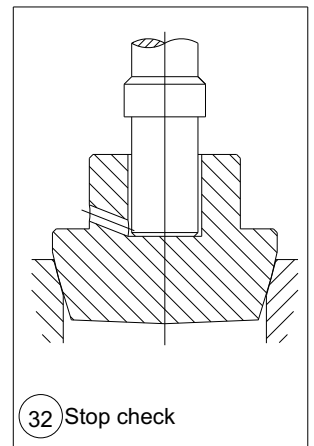
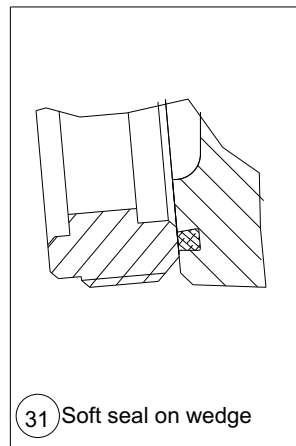
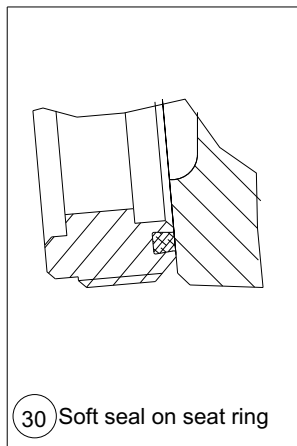
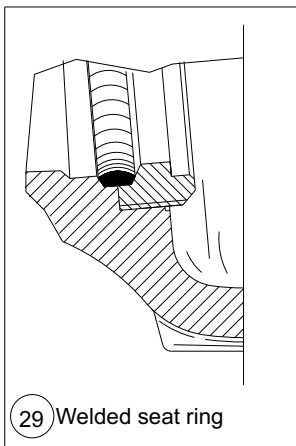
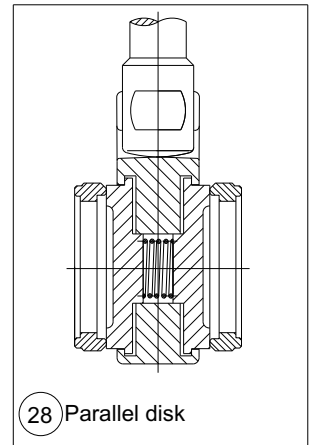
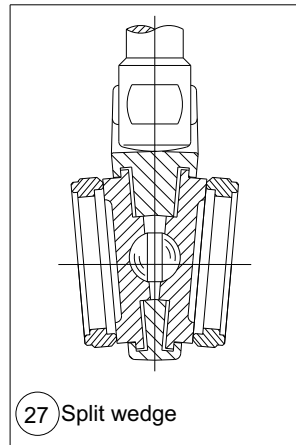
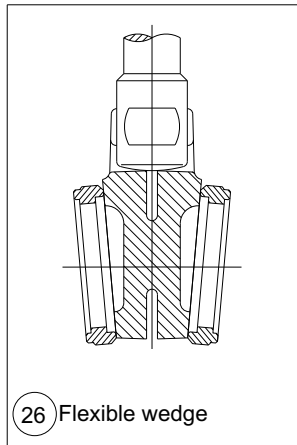
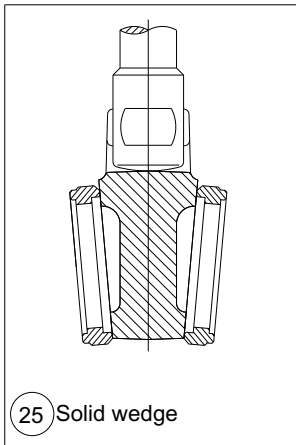
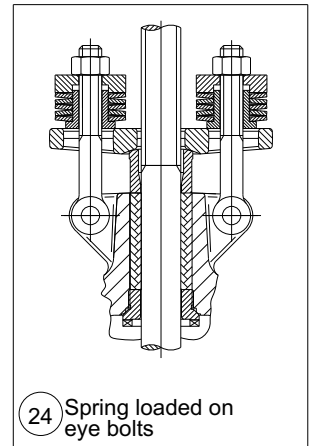
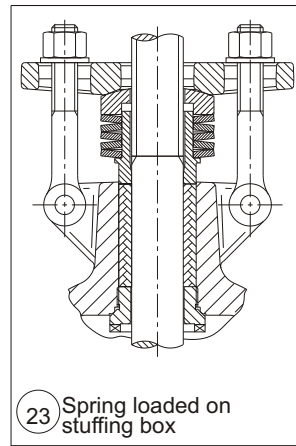
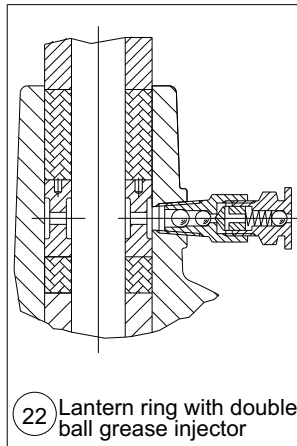
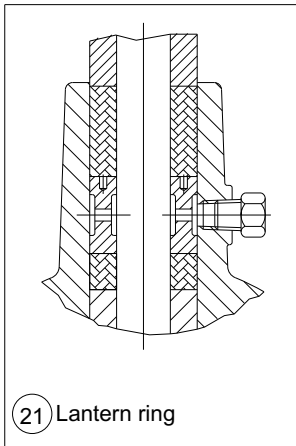
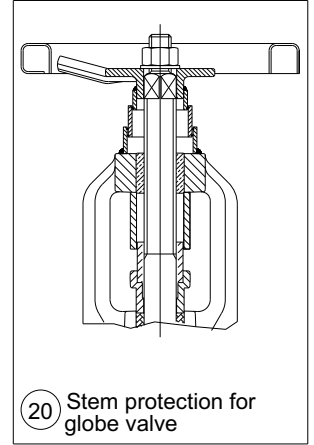
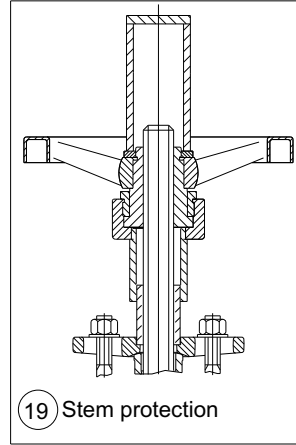
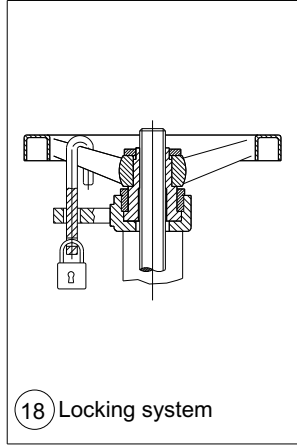
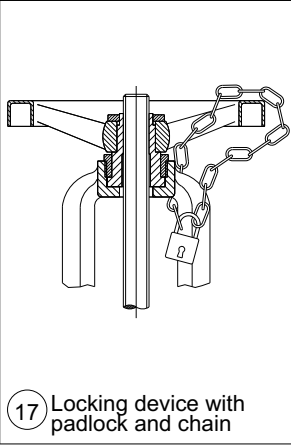

All data, subject to technical changes, are only for information and not for official use.

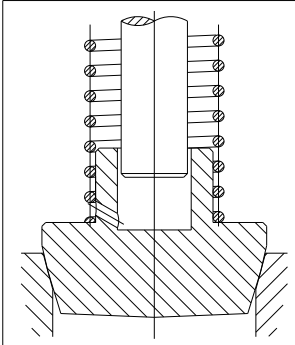

33 Stop check with spring

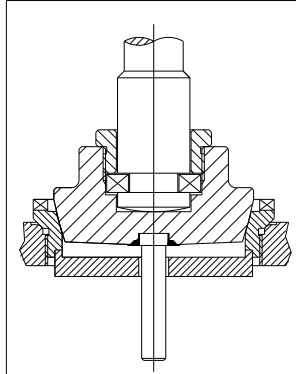

34 Guided disk

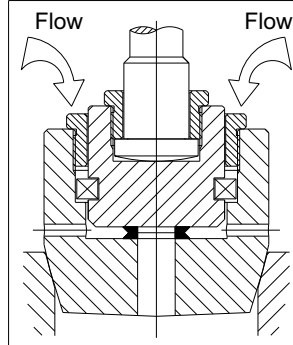

35 Double stage opening disk

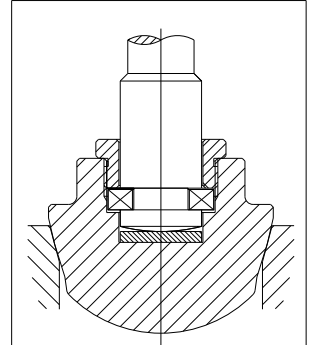

36 Parabolic / regulating disk

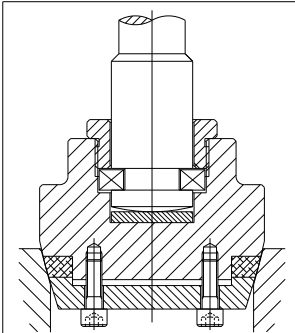

37 Soft seated disk

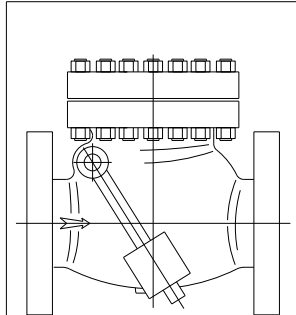

38 Swing check valve with outside lever and weight

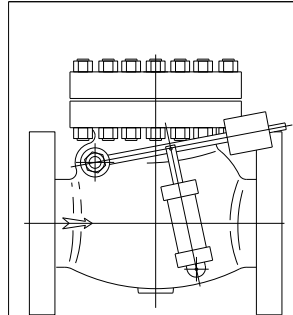

39 Swing check valve with shock absorber

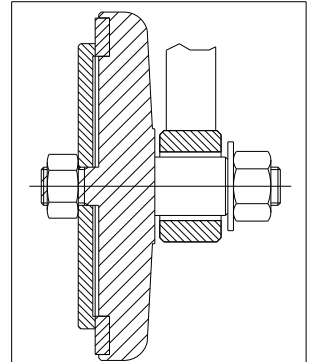

40 Soft seated disk for check valve

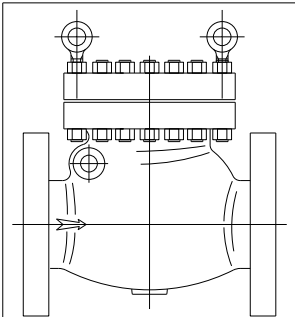

41 Swing check valve with lifting eyebolt

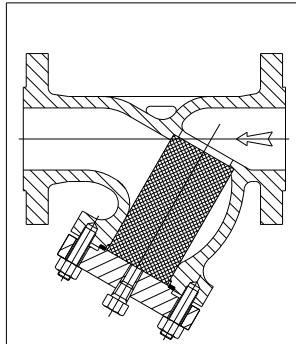

42 Strainer Y type with drain plug

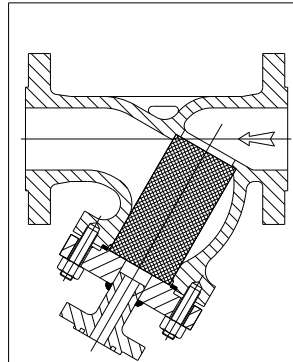

43 Strainer Y type with flange connection

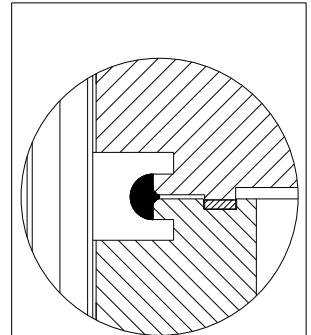

44 Body / bonnet seal weld

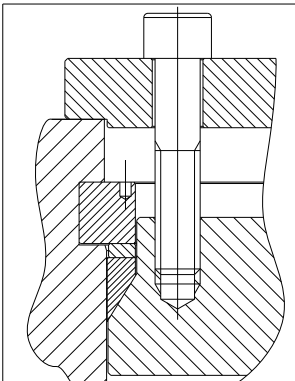

45 Pressure seal construction

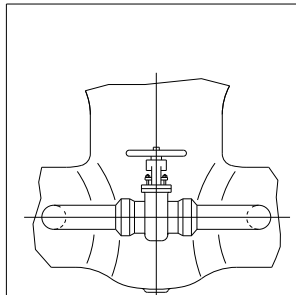

46 By pass (front view)

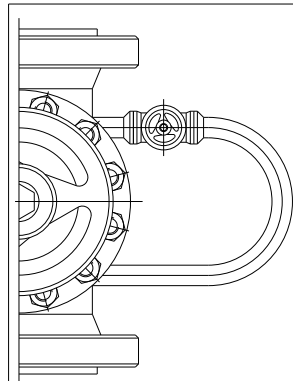

47 By pass (top view)

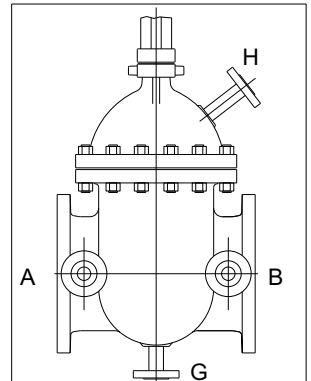

48 Flanges connection

All data, subject to technical changes, are only for information and not for official use.

FLANGES DIMENSIONS - ASME B16.5

SIZES 1/2" ÷ 24" - CLASSES 150 ÷ 2500

VALVOSIDER
MANUFACTURER OF VALVES

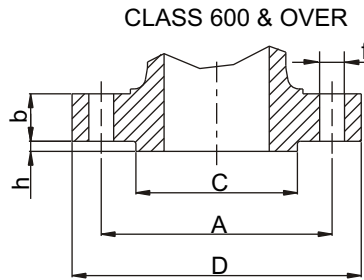
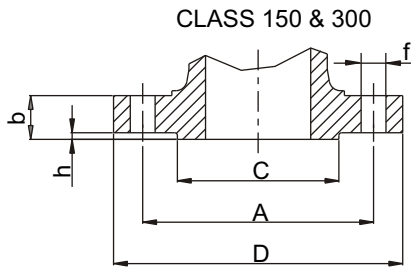

DN = Nominal pipe size (inches)
 D = Outside diameter of flange
 b* = Thickness of flange min.
 C = Diameter of hub
 h = Height of raised face
 N = Number of bolt holes
 f = Diameter of bolt holes
 A = Diameter of bolt circle
 RJ = Groove number

* raised face included for ANSI Class 150-300
 raised face not included for ANSI Class 600-900-1500-2500

CLASS	DN	D	b	C	h	N	f	A	RJ
150	1/2"	89	11,1	34,9	1,60	4	15	60,3	--
300	1/2"	95	14,3	34,9	1,60	4	15	66,7	11
600	1/2"	95	14,3	34,9	6,35	4	15	66,7	11
900-1500	1/2"	121	22,2	34,9	6,35	4	22	82,5	12
150	3/4"	98,4	12,7	42,9	1,60	4	15	69,8	--
300	3/4"	118	15,9	42,9	1,60	4	18	82,5	13
600	3/4"	118	15,9	42,9	6,35	4	18	82,5	13
900-1500	3/4"	130	25,4	42,9	6,35	4	22	88,9	14
150	1"	108	14,3	50,8	1,60	4	15	79,4	15
300	1"	124	17,5	50,8	1,60	4	19	88,9	16
600	1"	124	17,5	50,8	6,35	4	19	88,9	16
900-1500	1"	149	28,6	50,8	6,35	4	25	102	16
150	1 1/4"	118	15,9	63,5	1,60	4	15	88,9	17
300	1 1/4"	133	19	63,5	1,60	4	18	98,4	18
600	1 1/4"	133	20,6	63,5	6,35	4	18	98,4	18
900-1500	1 1/4"	159	28,6	63,5	6,35	4	26	111	18
150	1 1/2"	127	17,5	73	1,60	4	15	98,4	19
300	1 1/2"	156	20,6	73	1,60	4	22	114	20
600	1 1/2"	156	22,2	73	6,35	4	22	114	20
900-1500	1 1/2"	178	31,8	73	6,35	4	30	124	20
150	2"	152	19	92,1	1,60	4	19	121	22
300	2"	165	22,2	92,1	1,60	8	18	127	23
600	2"	165	25,4	92,1	6,35	8	18	127	23
900-1500	2"	216	38,1	92,1	6,35	8	26	165	24
2500	2"	235	50,8	92,1	6,35	8	29	171	26
150	2 1/2"	178	22,2	105	1,60	4	19	140	25
300	2 1/2"	191	25,4	105	1,60	8	22	149	26
600	2 1/2"	191	28,6	105	6,35	8	22	149	26
900-1500	2 1/2"	245	41,3	105	6,35	8	30	191	27
2500	2 1/2"	267	57,2	105	6,35	8	32	197	28
150	3"	191	23,8	127	1,60	4	19	152	29
300	3"	210	28,6	127	1,60	8	22	168	31
600	3"	210	31,8	127	6,35	8	22	168	31
900	3"	241	38,1	127	6,35	8	25	191	31
1500	3"	267	47,6	127	6,35	8	32	203	35
2500	3"	305	66,7	127	6,35	8	34,9	229	32
150	4"	229	23,8	157	1,60	8	19	191	36
300	4"	254	31,7	157	1,60	8	22	200	37
600	4"	273	38,1	157	6,35	8	26	216	37
900	4"	292	44,45	157	6,35	8	32	235	37
1500	4"	311	54	157	6,35	8	35	241	39
2500	4"	356	76,2	157	6,35	8	41	273	38
150	5"	254	23,8	186	1,60	8	22	216	40
300	5"	279	34,9	186	1,60	8	22	235	41
600	5"	330	44,4	186	6,35	8	28	267	41
900	5"	349	50,8	186	6,35	8	36	279	41
1500	5"	375	73	186	6,35	8	42	292	44
2500	5"	416	92,1	186	6,35	8	48	324	42

CLASS	DN	D	b	C	h	N	f	A	RJ
150	6"	279	25,4	216	1,6	8	22	241	43
300	6"	318	36,5	216	1,6	12	22	270	45
600	6"	356	47,6	216	6,35	12	30	292	45
900	6"	381	55,6	216	6,35	12	32	318	45
1500	6"	394	82,6	216	6,35	12	39	318	46
2500	6"	483	108	216	6,35	8	54	368	47
150	8"	343	28,6	270	1,6	8	22	298	48
300	8"	381	41,3	270	1,6	12	26	330	49
600	8"	419	55,6	270	6,35	12	32	349	49
900	8"	470	63,5	270	6,35	12	39	394	49
1500	8"	483	92,1	270	6,35	12	45	394	50
2500	8"	552	127	270	6,35	12	54	438	51
150	10"	406	30,2	324	1,6	12	25	362	52
300	10"	445	47,6	324	1,6	16	28,6	387	53
600	10"	508	63,5	324	6,35	16	36	432	53
900	10"	546	69,8	324	6,35	16	38,1	470	53
1500	10"	584	108	324	6,35	12	52	483	54
2500	10"	673	165	324	6,35	12	67	540	55
150	12"	483	31,7	381	1,6	12	26	432	56
300	12"	521	50,8	381	1,6	16	32	451	57
600	12"	559	66,7	381	6,35	20	36	490	57
900	12"	610	79,4	381	6,35	20	39	533	57
1500	12"	673	124	381	6,35	16	55	572	58
2500	12"	762	184	381	6,35	12	73	619	60
150	14"	533	34,9	413	1,6	12	29	476	59
300	14"	584	54	413	1,6	20	32	514	61
600	14"	603	69,8	413	6,35	20	39	527	61
900	14"	641	85,7	413	6,35	20	42	559	62
1500	14"	749	133	413	6,35	16	60	635	63
150	16"	597	36,5	470	1,6	16	28	540	64
300	16"	648	57,2	470	1,6	20	36	572	65
600	16"	686	76,2	470	6,35	20	42	603	65
900	16"	705	88,9	470	6,35	20	45	616	66
1500	16"	826	146	470	6,35	16	65	705	67
150	18"	635	39,7	533	1,6	16	32	578	68
300	18"	711	60,3	533	1,6	24	36	629	69
600	18"	743	82,6	533	6,35	20	45	654	69
900	18"	787	102	533	6,35	20	52	686	70
1500	18"	914	162	533	6,35	16	75	775	71
150	20"	699	42,9	584	1,6	20	32	635	72
300	20"	775	63,5	584	1,6	24	36	686	73
600	20"	813	88,9	584	6,35	24	45	724	73
900	20"	857	108	584	6,35	20	55	749	74
1500	20"	984	178	584	6,35	16	80	832	75
150	24"	813	47,6	692	1,6	20	36	749	76
300	24"	914	69,8	692	1,6	24	42	813	77
600	24"	940	102	692	6,35	24	52	838	77
900	24"	1041	140	692	6,35	20	65	902	78
1500	24"	1168	203	692	6,35	16	93	991	79

All dimensions in mm (except where differently indicated)

All data, subject to technical changes, are only for information and not for official use.

VALVOSIDER s.r.l. - Via S. Rocco, 2 - P.O. BOX 76 - 13011 Borgosesia (VC) - Italy
 Phone: +39016322991 - Fax: +39016321537 - www.valvosider.com - e-mail: valvo@valvosider.com

CLASS 150 & 300

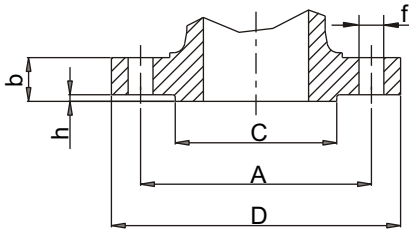

CLASS 600 & OVER

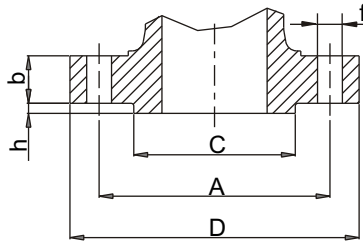

DN = Nominal pipe size (inches)
D = Outside diameter of flange
b* = Thickness of flange min.
C = Diameter of hub
h = Height of raised face
N = Number of bolt holes
f = Diameter of bolt holes
A = Diameter of bolt circle
RJ = Groove number

* raised face included for ANSI Class 150-300
raised face not included for ANSI Class 600-900

CLASS	DN	D	b	C	h	N	f	A	RJ	CLASS	DN	D	b	C	h	N	f	A	RJ
150	26"	870	68,3	749	1,6	24	35	806		150	38"	1238	87,4	1073	1,6	32	41	1149	
300	26"	972	79,2	749	1,6	28	44	876	93	300	38"	1168	108,0	1029	1,6	32	41	1092	
600	26"	1016	108,0	749	6,3	28	51	914	93	600	38"	1270	152,4	1054	6,3	28	60	1162	
900	26"	1086	139,7	953	6,3	20	73	953	100	900	38"	1461	190,5	1289	6,3	20	92	1289	
150	28"	927	71,4	800	1,6	28	35	864		150	40"	1289	90,4	1124	1,6	36	41	1200	
300	28"	1035	85,9	800	1,6	28	44	940	94	300	40"	1238	114,3	1086	1,6	32	44	1156	
600	28"	1073	111,3	800	6,3	28	54	965	94	600	40"	1321	158,8	1111	6,3	32	60	1213	
900	28"	1168	142,7	1022	6,3	20	79	1022	101	900	40"	1511	196,9	1340	6,3	24	92	1340	
150	30"	984	74,7	857	1,6	28	35	914		150	42"	1346	96,8	1194	1,6	36	41	1257	
300	30"	1092	91,9	857	1,6	28	48	997	95	300	42"	1289	119,1	1137	1,6	32	44	1207	
600	30"	1130	114,3	857	6,3	28	54	1022	95	600	42"	1403	168,1	1168	6,3	28	67	1283	
900	30"	1232	149,4	1086	6,3	20	79	1086	102	900	42"	1562	206,2	1391	6,3	24	92	1391	
150	32"	1060	81,0	914	1,6	28	41	978		150	44"	1403	101,6	1245	1,6	40	41	1314	
300	32"	1149	98,6	914	1,6	28	51	1054	96	300	44"	1353	124,0	1194	1,6	32	48	1264	
600	32"	1194	117,3	914	6,3	28	60	1080	96	600	44"	1454	173,0	1226	6,3	32	67	1334	
900	32"	1314	158,8	1156	6,3	20	86	1156	103	900	44"	1648	214,4	1464	6,3	24	99	1464	
150	34"	1111	82,6	965	1,6	32	41	1029		150	46"	1454	103,1	1295	1,6	40	41	1365	
300	34"	1207	101,6	965	1,6	28	51	1105	97	300	46"	1416	128,5	1245	1,6	28	51	1321	
600	34"	1245	120,7	965	6,3	28	60	1130	97	600	46"	1511	179,3	1276	6,3	32	67	1391	
900	34"	1397	165,1	1226	6,3	20	92	1226	104	900	46"	1734	225,6	1537	6,3	24	105	1537	
150	36"	1168	90,4	1022	1,6	32	41	1086		150	48"	1511	108,0	1359	1,6	44	41	1422	
300	36"	1270	104,6	1022	1,6	32	54	1168	98	300	48"	1467	133,4	1302	1,6	32	51	1372	
600	36"	1314	124,0	1022	6,3	28	67	1194	98	600	48"	1594	189,0	1334	6,3	32	73	1461	
900	36"	1461	171,5	1289	6,3	20	92	1289	105	900	48"	1784	233,4	1588	6,3	24	105	1588	

FLANGES FACING FINISH

NOMINAL ROUGHNESS GRADES (R_a) FOR ROUGHNESS COMPARISON SPECIMENS - ASME B46.1

µm	µin.
0.006	0.25
0.0125	0.5
0.025	1
0.05	2
0.1	4
0.2	8
0.4	16
0.8	32
1.6	63
3.2	125
6.3	250
12.5	500
25	1,000
50	2,000
100	4,000
200	8,000
400	16,000

ASME B16.5

TONGUE AND GROOVE - SMALL MALE AND FEMALE

The gasket contact surface shall not exceed 125 microinches (3,2 micrometers) roughness.

RING JOINT

The side wall surface of gasket groove shall not exceed 63 microinches (1,6 micrometers) roughness.

OTHER FLANGE FACINGS

Either a serrated concentric or serrated spiral finish having a resultant surface finish from 125 microinches to 250 microinches (3,2 to 6,3 micrometers) average roughness.

MSS SP-6 - steel

FLAT OR 1/6" (1.6 mm) RAISED FACE AND 1/4" (6.4 mm) RAISED AND LARGE MALE & FEMALE

Serrated: spiral or concentric, 45 to 55 per inch (18 to 21 per cm). Surface finish shall have a 125 to 250 microinches (3.2 to 6.3 micrometers) Ra.

SMALL MALE & FEMALE, LARGE & SMALL TONGUE & GROOVE

Serrated (as above) or non-serrated: 125 microinches (3,2 micrometers) Ra max.

RING JOINT

Non-serrated: 63 microinches (1.6 micrometers) Ra max. according to ASME B46.1.

The finish of contact faces of pipe flanges and connecting end flanges of fittings shall be judged by visual comparison with Ra standards.

All dimensions in mm (except where differently indicated)

All data, subject to technical changes, are only for information and not for official use.

END FLANGE FACINGS - ASME B16.5

VALVOSIDER
MANUFACTURER OF VALVES

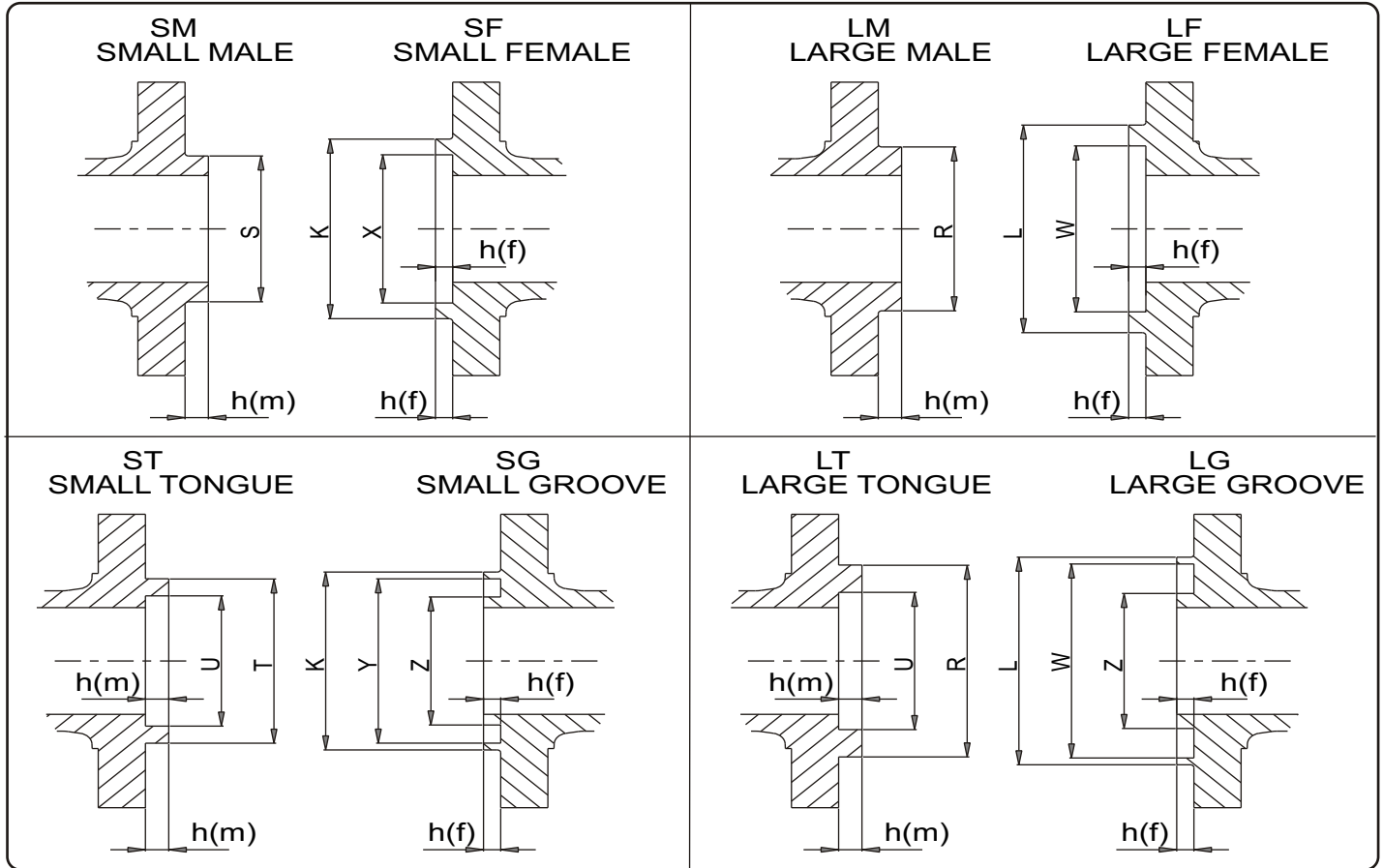

FACE TO FACE DIMENSIONS - ASME B16.10

CLASS	RF	MALE	FEMALE
150 / 300	SEE CATALOGUE	RF + 13 mm	RF + 10 mm
600 / 900 / 1500	SEE CATALOGUE	RF	RF - 3 mm

DIMENSIONS OF FACING (mm)

Nominal pipe size (inches)	OUTSIDE DIAMETER			INT. DIAM.	OUTSIDE DIAMETER			INT. DIAM.	RAISED FACE HEIGHT		Depth of groove or female	OUTSIDE DIAMETER OF RAISED PORTION	
	Raised face, lapped, large male and large tongue	Small male **	Small tongue		Large and small tongue	Large female and large groove	Small female		Small groove	Large and small groove **		150 and 300 Lbs. Class	Large and small male and tongue 400/2500 Lbs. Class
	R	S	T	U	W	X	Y	Z	h	h(m)	h(f)	K	L
1 1/2"	73,1	44,4	63,5	53,8	74,6	45,9	65	52,3	1,6	6,35	4,8	73	84,1
2"	91,8	57,1	82,5	73,1	93,7	58,7	84,1	71,4	1,6	6,35	4,8	92	103,1
2 1/2"	104,6	68,3	95,2	85,8	106,4	69,8	96,8	84,1	1,6	6,35	4,8	105	115,8
3"	127,0	84,1	117,3	107,9	128,5	85,8	119,1	106,4	1,6	6,35	4,8	127	138,2
4"	157,2	109,5	144,5	131,8	158,7	111,2	146,0	130,0	1,6	6,35	4,8	157	168,1
5"	185,7	136,6	173,0	160,3	187,4	138,1	174,7	158,7	1,6	6,35	4,8	186	196,8
6"	215,9	162,0	203,2	190,5	217,5	163,5	204,7	188,9	1,6	6,35	4,8	216	227,0
8"	269,7	212,8	254,0	238,2	271,5	214,3	255,5	236,5	1,6	6,35	4,8	270	281,0
10"	323,8	266,7	304,8	285,7	325,4	268,2	306,3	284,2	1,6	6,35	4,8	324	335,0
12"	381,0	317,5	361,9	342,9	382,5	319,0	363,5	341,3	1,6	6,35	4,8	381	392,1
14"	412,7	349,2	393,7	374,6	414,3	350,8	395,3	373,1	1,6	6,35	4,8	413	423,9
16"	469,9	400,0	447,5	425,4	471,4	401,6	449,3	423,9	1,6	6,35	4,8	470	481,0
18"	533,4	450,8	511,0	488,9	535,0	452,4	512,8	487,4	1,6	6,35	4,8	533	544,5
20"	584,2	501,6	558,8	533,4	585,7	503,2	560,3	531,8	1,6	6,35	4,8	584	595,3
24"	692,1	603,2	666,7	641,3	693,7	604,8	668,8	639,8	1,6	6,35	4,8	692	703,3

**Large male and female faces and large tongue and groove are not applicable to Class 150 because of potential dimensional conflict.

All dimensions in mm (except where differently indicated)

All data, subject to technical changes, are only for information and not for official use.

VALVOSIDER s.r.l. - Via S. Rocco, 2 - P.O. BOX 76 - 13011 Borgosesia (VC) - Italy
Phone: +39016322991 - Fax: +39016321537 - www.valvosider.com - e-mail: valvo@valvosider.com

BUTT WELDING ENDS - ASME B16.25

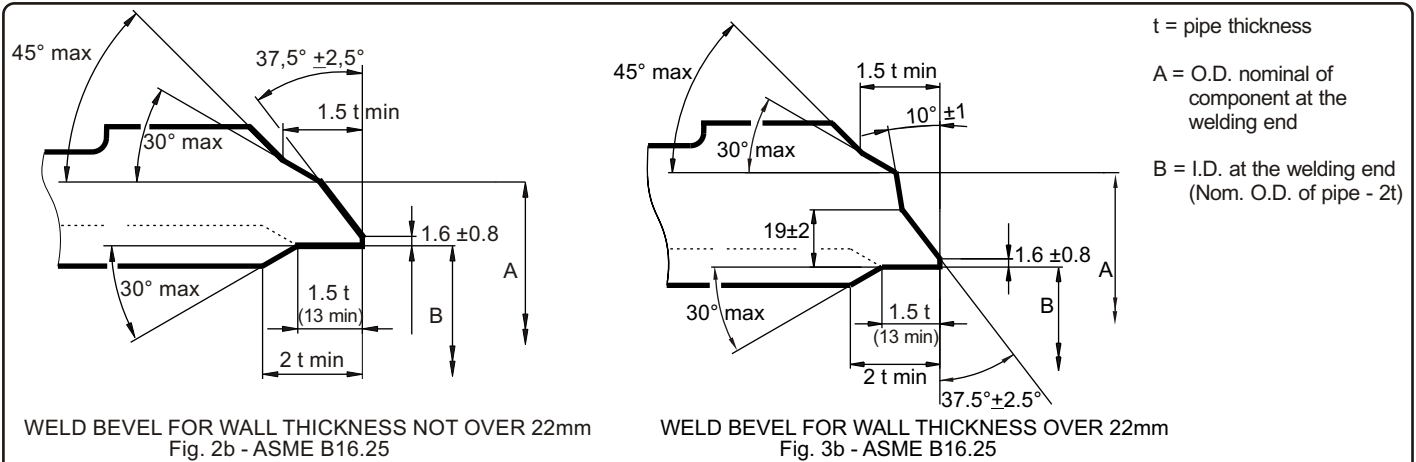

DN (inches)	Nom. pipe O.D.	A (1)	Wall thickness of pipe											
			sch. 20	sch. 30	sch. Std	sch. 40	sch. 60	sch. xs	sch. 80	sch. 100	sch. 120	sch. 140	sch. 160	sch. xxs
1" 1/2	48.3	n.a.			3.68	3.68		5.08	5.08				7.14	10.16
2"	60.3	n.a.			3.91	3.91		5.54	5.54				8.74	11.07
2" 1/2	73.0	75			5.16	5.16		7.01	7.01				9.52	14.02
3"	88.9	91			5.49	5.49		7.62	7.62				11.13	15.24
4"	114.3	117			6.02	6.02		8.56	8.56		11.13		13.49	17.12
5"	141.3	144			6.55	6.55		9.52	9.52		12.70		15.88	19.05
6"	168.3	172			7.11	7.11		10.97	10.97		14.27		18.26	21.95
8"	219.1	223	6.35	7.04	8.18	8.18	10.31	12.70	12.70	15.09	18.26	20.62	23.01	22.22
10"	273.0	278	6.35	7.80	9.27	9.27	12.70	12.70	15.09	18.26	21.44	25.40	28.58	25.40
12"	323.8	329	6.35	8.38	9.52	10.31	14.27	12.70	17.48	21.44	25.40	28.57	33.32	
14"	355.6	362	7.92	9.52	9.52	11.12	15.09	12.70	19.05	23.83	27.76	31.75	35.71	
16"	406.4	413	7.92	9.52	9.52	12.70	16.66	12.70	21.44	26.19	30.94	36.52	40.46	
18"	457.2	464	7.92	11.13	9.52	14.27	19.05	12.70	23.83	29.36	34.92	39.67	45.24	
20"	508.0	516	9.52	12.70	9.52	15.06	20.62	12.70	26.19	32.54	38.10	44.45	49.99	
24"	609.6	619	9.52	14.27	9.52	17.45	24.59	12.70	30.94	38.89	46.02	52.37	59.51	

(1) The diameters listed are not requirements

SOCKET WELDING ENDS - ASME B16.11 (not for auxiliary connections - see ASME B16.34)

DN mm	Nominal pipe size (inches)	B mm (min.)	J mm (min.)	Class 3000 Sch. 80		Class 6000 Sch. 160		Class 9000 Wall Des. XXS	
				C mm (min.)	D mm (min.)	C mm (min.)	D mm (min.)	C mm (min.)	D mm (min.)
6	1/8"	10,8	9,5	3,18	6,1	3,43	3,2	--	--
8	1/4"	14,2	9,5	3,30	8,5	4,01	5,6	--	--
10	3/8"	17,6	9,5	3,50	11,8	4,37	8,4	--	--
15	1/2"	21,8	9,5	4,09	15,0	5,18	11,0	5,94	5,6
20	3/4"	27,2	12,5	4,27	20,2	6,04	14,8	6,93	10,3
25	1"	33,9	12,5	4,98	25,9	6,93	19,9	7,95	14,4
32	1" 1/4	42,7	12,5	5,28	34,3	9,93	28,7	7,95	22,0
40	1" 1/2	48,8	12,5	5,54	40,1	7,80	33,2	8,91	27,2
50	2"	61,2	16,0	6,04	51,7	9,50	42,1	10,89	37,4
65	2" 1/2	73,9	16,0	7,67	61,2	--	--	--	--
80	3"	89,8	16,0	8,30	76,4	--	--	--	--
100	4"	115,2	16,0	9,35	100,7	--	--	--	--

All dimensions in mm (except where differently indicated)

All data, subject to technical changes, are only for information and not for official use.

AUXILIARY CONNECTION - TAPS - DRAINS - BY PASSES

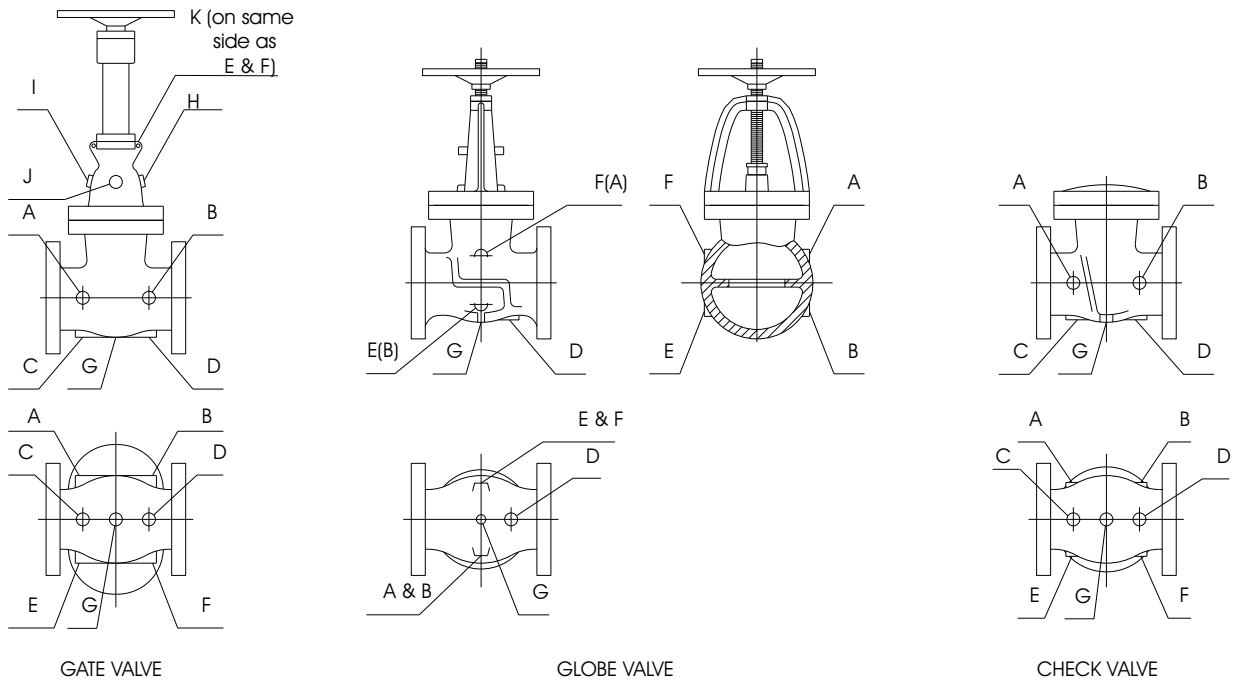

AUXILIARY CONNECTIONS - BYPASS AND DRAIN CONNECTIONS

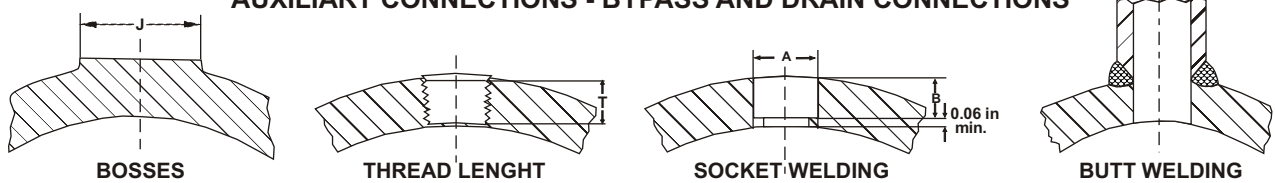

Size of Valve	2" to 4"	5" to 8"	10" to 24"
Size of Connections	1/2"	3/4"	1"
Length of Thread T	14	14	18
Min.Diam. of Socket A	22	27	34
Min.Depth. of Socket B	5	6.5	6.5
Diameter of Boss J	38	44	54
Size of Tapping	1/2"	3/4"	1"

NPT THREAD STANDARDS - ASME B1.20.1

$p = \text{Pitch}$
 $\text{Depth of thread} = 0.80p$
 $E0 = D - (0.050d + 1.1)p$
 $E1 = E0 + 0.0625L1$
 $L2 = (0.80D + 6.8)p$

NOMINAL PIPE SIZE (INCH)	OUTSIDE DIAMETER OF PIPE	THREADS PER INCH	PITCH OF THREAD	HANDTIGHT ENGAGEMENT	LENGTH OF EFFECTIVE THREAD (EXTERNAL)	WRENCH MAKEUP LENGTH FOR INTERNAL THREAD	OVERALL LENGTH EXTERNAL THREAD	PITCH DIAM. AT BEGINNING OF EXTERNAL THREAD
DN	D	(n)	P	L1	L2	L3	L4	E0
1/8	10,29	27	0,940	4,572	6,703	2,822	9,967	9,233
1/4	13,72	18	1,412	5,080	10,206	4,234	15,103	12,126
3/8	17,14	18	1,412	6,096	10,358	4,234	15,255	15,545
1/2	21,34	14	1,814	8,128	13,556	5,443	19,850	19,263
3/4	26,67	14	1,814	8,611	13,861	5,443	20,155	24,58
1	33,40	11,5	2,210	10,160	17,343	6,627	25,006	30,825
1 1/4	42,16	11,5	2,210	10,668	17,953	6,627	25,616	39,55
1 1/2	48,26	11,5	2,210	10,668	18,377	6,627	26,040	45,621
2	60,32	11,5	2,210	11,074	19,215	6,627	26,878	57,633

All dimensions in mm (except where differently indicated)

All data, subject to technical changes, are only for information and not for official use.

	ASTM		chemical composition %									mechanical properties			
	Number	Grade	C	Mn	P	S	Si	Cr	Mo	Ni	others	Mpa		% Ap.	% C
CASTINGS	A 216	WCB	max. 0,30	max. 1,00	max. 0,04	max. 0,045	max. 0,60	--	--	--	--	485	250	22	35
	A 352	LCB	max. 0,30	max. 1,00	max. 0,04	max. 0,045	max. 0,60	--	--	--	--	450	240	24	35
	A 352	LC 2	max. 0,25	0,50 - 0,80	max. 0,04	max. 0,045	max. 0,60	--	--	2,00 - 3,00	--	485	275	24	35
	A 352	LC 3	max. 0,15	0,50 - 0,80	max. 0,04	max. 0,045	max. 0,60	--	--	3,00 - 4,00	--	485	275	24	35
	A 217	WC 1	max. 0,25	0,50 - 0,80	max. 0,04	max. 0,045	max. 0,60	--	0,45 - 0,65	--	--	450	240	24	35
	A 217	WC 5	max. 0,20	0,40 - 0,70	max. 0,04	max. 0,045	max. 0,60	0,50 - 0,90	0,90 - 1,20	0,60 - 1,00	--	485	275	20	35
	A 217	WC 6	max. 0,20	0,50 - 0,80	max. 0,04	max. 0,045	max. 0,60	1,00 - 1,50	0,45 - 0,65	--	--	485	275	20	35
	A 217	WC 9	max. 0,18	0,40 - 0,70	max. 0,04	max. 0,045	max. 0,60	2,00 - 2,75	0,90 - 1,20	--	--	485	275	20	35
	A 217	C 5	max. 0,20	0,40 - 0,70	max. 0,04	max. 0,045	max. 0,75	4,00 - 6,50	0,45 - 0,65	--	--	620	415	18	35
	A 217	C 12	max. 0,20	0,35 - 0,65	max. 0,04	max. 0,045	max. 1,00	8,00 - 10,00	0,90 - 1,20	--	--	620	515	18	35
	A 217	CA 15	max. 0,15	max. 1,00	max. 0,04	max. 0,04	max. 1,50	11,50 - 14,00	max. 0,50	max. 1,00	--	620	450	18	30
	A 351	CF 3	max. 0,03	max. 1,50	max. 0,04	max. 0,04	max. 2,00	17,00 - 21,00	max. 0,50	8,00 - 12,00	--	485	205	35	--
	A 351	CF 8	max. 0,08	max. 1,50	max. 0,04	max. 0,04	max. 2,00	18,00 - 21,00	max. 0,50	8,00 - 11,00	--	485	205	35	--
	A 351	CF 8 C	max. 0,08	max. 1,50	max. 0,04	max. 0,04	max. 2,00	18,00 - 21,00	--	9,00 - 12,00	Cb min. 8xC max. 1,00	485	205	30	--
	A 351	CF 3 M	max. 0,03	max. 1,50	max. 0,04	max. 0,04	max. 1,50	17,00 - 21,00	2,00 - 3,00	9,00 - 13,00	--	485	205	30	--
	A 351	CF 8 M	max. 0,08	max. 1,50	max. 0,04	max. 0,04	max. 1,50	18,00 - 21,00	2,00 - 3,00	9,00 - 12,00	--	485	205	30	--
	A 351	CG 8M	max. 0,08	max. 1,50	max. 0,04	max. 0,04	max. 1,50	18,00 - 21,00	3,00 - 4,00	9,00 - 13,00	--	515	240	25	--
	A 351	CK3MCuN	max. 0,025	max. 1,20	max. 0,045	max. 0,01	max. 1,00	19,50 - 20,50	6,00 - 7,00	17,50 - 19,50	Cu 0,5 - 1,00 N 0,18-0,24	550	260	35	--
	A 351	CN7M	max. 0,07	max. 1,50	max. 0,04	max. 0,04	max. 1,50	19,00 - 22,00	2,00 - 3,00	27,50 - 30,50	Cu 3,0 - 4,0	425	170	35	--
	A 890	4A	max. 0,03	max. 1,50	max. 0,04	max. 0,02	max. 1,0	21,00 - 23,50	2,50 - 3,50	4,50 - 6,50	Cu max 1,00 N 0,10-0,30	620	415	25	--
A 890	5A	max. 0,03	max. 1,50	max. 0,04	max. 0,04	max. 1,0	24,00 - 26,00	4,00 - 5,00	6,00 - 8,00	N 0,10-0,30	690	515	18	--	
A 890	6A	max. 0,03	max. 1,00	max. 0,03	max. 0,025	max. 1,0	24,00 - 26,00	3,00 - 4,00	6,50 - 8,50	Cu&W 0,5-1,0 N 0,20-0,30	700	450	25	--	
FORGINGS	A 105	II	max. 0,35	max. 0,90	max. 0,05	max. 0,05	max. 0,35	--	--	--	--	485	250	22	30
	A 181	CL 60	max. 0,35	max. 0,90	max. 0,05	max. 0,05	max. 0,35	--	--	--	--	415	205	22	35
	A 181	CL 70	max. 0,35	max. 0,90	max. 0,05	max. 0,05	max. 0,35	--	--	--	--	485	250	18	24
	A 350	LF 2	max. 0,35	0,60 - 1,35	max. 0,35	max. 0,04	0,15 - 0,30	max. 0,30	max. 0,12	max. 0,40	Cu max 0,40	485	250	22	30
	A 350	LF 3	max. 0,20	max. 0,90	max. 0,035	max. 0,04	0,20 - 0,35	--	--	3,30 - 3,70	--	485	260	22	35
	A 182	F 1	max. 0,28	0,60 - 0,90	max. 0,045	max. 0,045	0,15 - 0,35	--	0,44 - 0,65	--	--	485	275	20	30
	A 182	F 5	max. 0,15	0,30 - 0,60	max. 0,03	max. 0,03	max. 0,50	4,00 - 6,00	0,44 - 0,65	max. 0,50	--	485	275	20	35
	A 182	F 6a CL.2	max. 0,12	max. 1,00	max. 0,04	max. 0,03	max. 1,00	11,50 - 13,50	--	max. 0,50	--	585	380	18	35
	A 182	F 9	max. 0,15	0,30 - 0,60	max. 0,03	max. 0,03	0,50 - 1,00	8,00 - 10,00	0,90 - 1,10	--	--	585	380	20	40
	A 182	F 10	0,01 - 0,20	0,50 - 0,80	max. 0,03	max. 0,03	1,00 - 1,40	7,00 - 9,00	--	19,00 - 22,00	--	550	205	30	50
	A 182	F 11 CL.2	0,05 - 0,15	0,30 - 0,60	max. 0,03	max. 0,03	0,50 - 1,00	1,00 - 1,50	0,44 - 0,65	--	--	485	275	20	30
	A 182	F 12 CL.2	0,10 - 0,20	0,30 - 0,80	max. 0,04	max. 0,04	0,10 - 0,60	0,80 - 1,25	0,44 - 0,65	--	--	485	275	20	30
	A 182	F 20	max. 0,07	max. 2,00	max. 0,045	max. 0,035	max. 1,00	19,00 - 21,00	2,00 - 3,00	32,00 - 38,00	--	550	240	30	50
	A 182	F 22	0,05 - 0,15	0,30 - 0,60	max. 0,04	max. 0,04	max. 0,50	2,00 - 2,50	0,87 - 1,13	--	--	415	205	20	35
	A 182	F 44	max. 0,02	max. 1,00	max. 0,03	max. 0,01	max. 0,80	19,5 - 20,5	6,0 6,5	17,5 - 18,5	Cu 0,50-1,00 N 0,18-0,22	650	300	35	50
	A 182	F 51	max. 0,03	max. 2,00	max. 0,03	max. 0,02	max. 1,00	21,0 - 23,0	2,5 3,5	4,5 - 6,5	N min 0,08 max 0,20	620	450	25	45
	A 182	F 53	max. 0,03	max. 1,20	max. 0,035	max. 0,02	max. 0,80	24,0 - 26,0	3,0 5,0	6,0 - 8,0	Cu max 0,50 N 0,24-0,32	750	515	15	--
	A 182	F 304	max. 0,08	max. 2,00	max. 0,045	max. 0,03	max. 1,00	18,00 - 20,00	--	8,00 - 11,00	--	515	205	30	50
	A 182	F 310	max. 0,15	max. 2,00	max. 0,045	max. 0,03	max. 1,00	24,00 - 26,00	--	19,00 - 22,00	--	515	205	30	50
	A 182	F 316	max. 0,08	max. 2,00	max. 0,045	max. 0,03	max. 1,00	16,00 - 18,00	2,00 - 3,00	10,00 - 14,00	--	515	205	30	50
	A 182	F 316L	max. 0,035	max. 2,00	max. 0,045	max. 0,03	max. 1,00	16,00 - 18,00	2,00 - 3,00	10,00 - 15,00	--	485	170	30	50
	A 182	F 321	max. 0,08	max. 2,00	max. 0,045	max. 0,03	max. 1,00	min. 17,00	--	9,00 - 12,00	Ti min. 5xC max. 0,70	515	205	30	50
	A 182	F 347	max. 0,08	max. 2,00	max. 0,045	max. 0,03	max. 1,00	17,00 - 20,00	--	9,00 - 13,00	Cb min. 10xC max. 1,00	515	205	30	50
	AISI	431	max. 0,20	max. 1,00	max. 0,04	max. 0,03	max. 1,00	15,00 - 17,00	--	1,25 - 2,50	--	--	--	--	--
	17.4 PH	®	max. 0,07	max. 1,00	max. 0,04	max. 0,03	max. 1,00	15,00 - 17,50	max. 0,50	3,00 - 5,00	Cbmin. 8xC/max. 1 Cu 0,5 - 1,0	860	725	16	50
	BOLTINGS	A 193	B 7	0,37 - 0,49	0,65 - 1,10	max. 0,035	max. 0,04	0,15 - 0,35	0,75 - 1,20	0,15 - 0,25	--	--	860	720	16
A 193		B 16	0,36 - 0,47	0,45 - 0,70	max. 0,035	max. 0,04	0,15 - 0,35	0,80 - 1,15	0,50 - 0,65	--	Va 0,25-0,35	860	725	18	50
A 193		B 8	max. 0,08	max. 2,00	max. 0,045	max. 0,03	max. 1,00	18,00 - 20,00	--	8,00 - 10,50	--	*	*	*	*
A 193		B 8M	max. 0,08	max. 2,00	max. 0,045	max. 0,03	max. 1,00	16,00 - 18,00	2,00 - 3,00	10,00 - 14,00	--	*	*	*	*
A 320		B 8	max. 0,08	max. 2,00	max. 0,045	max. 0,03	max. 1,00	18,00 - 20,00	--	8,00 - 10,50	--	*	*	*	*
A 320		L 7	0,38 - 0,48	0,75 - 1,00	max. 0,035	max. 0,04	0,15 - 0,35	0,80 - 1,10	0,15 - 0,25	--	--	860	725	16	50
A 194		2 H	min. 0,40	max. 1,00	max. 0,04	max. 0,05	max. 0,4	--	--	--	--	--	--	--	--
A 194		3	max. 0,10	max. 1,00	max. 0,04	max. 0,03	max. 1,00	4,00 - 6,00	0,40 - 0,65	--	--	--	--	--	--
A 194		4	0,40 - 0,50	0,70 - 0,90	max. 0,035	max. 0,04	0,15 - 0,35	--	0,20 - 0,30	--	--	--	--	--	--
A 194		8	max. 0,08	max. 2,00	max. 0,045	max. 0,03	max. 1,00	18,00 - 20,00	--	8,00 - 10,50	--	--	--	--	--
A 194	8M	max. 0,08	max. 2,00	max. 0,045	max. 0,03	max. 1,00	16,00 - 18,00	2,00 - 3,00	10,00 - 14,00	--	--	--	--	--	

All data, subject to technical changes, are only for information and not for official use.

TRIM MATERIALS API STANDARD 600

VALVOSIDER
MANUFACTURER OF VALVES

API 600 TRIM No.	MATERIAL TYPE					SERVICE
	DISC / WEDGE SEAT SURFACES (1)	SEAT RING SURFACES (1)	STEM HINGE PIN (2)	BACK SEAT	SMALL INTERNAL PARTS	
1	13Cr	13Cr	13Cr	13Cr	13Cr	General erosive or non-corrosive service between -100 °C and 400 °C
2	18Cr - 8Ni	18Cr - 8Ni	18Cr - 8Ni	18Cr - 8Ni	18Cr - 8Ni	For moderate pressure in non-erosive, corrosive service between -265 °C and 320 °C
3	25Cr - 20Ni	25Cr - 20Ni	25Cr - 20Ni	25Cr - 20Ni	25Cr - 20Ni	For moderate pressure in corrosive or non corrosive service between -265 °C and 450 °C
4	Hard 13Cr	Hard 13Cr	13Cr	13Cr	13Cr	As trim No. 1 but for medium pressure
5	HF	HF	13Cr	13Cr	13Cr	High pressure slightly erosive and corrosive service between -265 °C and 650 °C
5A	HF (A)	HF (A)	13Cr	13Cr	13Cr	As trim No. 5 where Co is not allowed
6	13Cr	NiCu alloy	13Cr	13Cr	13Cr	As trim No. 1
7	13Cr	Hard 13Cr	13Cr	13Cr	13Cr	As trim No. 1 for moderate pressure
8	13Cr	HF	13Cr	13Cr	13Cr	As trim No. 5 for moderate pressure
8A	13Cr	HF (A)	13Cr	13Cr	13Cr	As trim No. 5A for moderate pressure
9	NiCu alloy	NiCu alloy	NiCu alloy	NiCu alloy	NiCu alloy	Very corrosive fluids, erosive-corrosive service between -240 °C and 480 °C
10	18Cr - 8Ni - Mo	18Cr - 8Ni - Mo	18Cr - 8Ni - Mo	18Cr - 8Ni - Mo	18Cr - 8Ni - Mo	As trim No. 2
11	NiCu alloy	HF	NiCu alloy	NiCu alloy	NiCu alloy	As trim No. 9 but for medium pressure
12	18Cr - 8Ni - Mo	HF	18Cr - 8Ni - Mo	18Cr - 8Ni - Mo	18Cr - 8Ni - Mo	As trim No. 10 but for medium pressure
13	19Cr - 29Ni	19Cr - 29Ni	19Cr - 29Ni	19Cr - 29Ni	19Cr - 29Ni	Very corrosive service, for moderate pressure between -45 °C and 320 °C
14	19Cr - 29Ni	HF	19Cr - 29Ni	19Cr - 29Ni	19Cr - 29Ni	As trim No. 13 but for medium pressure
15	HF	HF	18Cr - 8Ni	18Cr - 8Ni	18Cr - 8Ni	As trim No. 2
16	HF	HF	18Cr - 8Ni - Mo	18Cr - 8Ni - Mo	18Cr - 8Ni - Mo	As trim No. 10
17	HF	HF	18Cr - 10Ni	18Cr - 10Ni	18Cr - 10Ni	As trim No. 2
18	HF	HF	19Cr - 29Ni	19Cr - 29Ni	19Cr - 29Ni	As trim No. 13

NOTES:

1) The base materials of disc, wedge and seat ring shall be, at least, equal in corrosion resistance to that of the body material. (Acc. to API Standard 600)

2) Stem shall be wrought material.

Cr = chromium; Ni = nickel; Co = cobalt; Mo = molybdenum. Ni-Cu alloy = Monel

HF = Hard Facing using CoCr (commercial name Stellite®) welding wire or electrode AWS a 5.13 "E-Co-Cr-A" hb >= 350; thickness 1.6 mm NiCr welding alloy. The suffix A applies to NiCr (5A..8A..)

CHEMICAL COMPOSITION AND MECHANICAL PROPERTIES OF OTHER MATERIALS

ASTM designation	chemical composition %													mechanical properties		
	Ni	Cu	Fe	Mo	Mn	C	Cr	Si	S	Ti	W	Co	Al	Mpa		%
														R	S	Ap.
Hastelloy B ®	61	--	5	28	--	0,05	1	--	--	--	--	2,5	--	588-902	343-392	15 - 50
Hastelloy C ®	54	--	6	16	--	0,08	15,1	--	--	--	4	2,5	--	549-892	353-471	10 - 49
Monel 8 400 ®	63 - 68	remaining	3,0	--	0,5 - 1,5	0,12	--	3,5 - 4,0	0,05	--	--	--	--	618-696	--	--
Monel K 500 ®	63 - 70	27 - 33	2,0	--	1,5	0,25	--	1,0	0,01	--	--	--	2,0 - 4,0	892-1049	559-755	30 - 20
Stellite N. 6 ®	--	--	--	--	0,25	1,40	29	1,20	--	--	8	60	--	--	--	--
Inconel 625 ®	min. 58	--	max. 5,0	8.0 - 10.0	max. 0,5	max. 0,1	22.0 - 23.0	max. 0,5	max. 0,015	max. 0,4		max. 1.0	max. 0,4	896	483	50

All data, subject to technical changes, are only for information and not for official use.

VALVOSIDER s.r.l. - Via S. Rocco, 2 - P.O. BOX 76 - 13011 Borgosesia (VC) - Italy
Phone: +39016322991 - Fax: +39016321537 - www.valvosider.com - e-mail: valvo@valvosider.com

MATERIALS		WCB(a)	WCC(a) LCC(b) LC2(b) LC3(b)	LCB(b)	WC1(h) LC1(b)	WC4(j) WC5	WC6(m)	WC9(m)	C5	C12	CF3(e) CF8(g)	CF8M(g) CF3M(f)	CF8C(g)
CLASS	TEMPERATURE °C	Working pressure (bars)											
150 (PN 20)	- 29 to 38	19,6	20,0	18,4	18,4	20,0	20,0	20,0	20,0	20,0	19,0	19,0	19,0
	50	19,2	19,2	18,1	18,3	19,3	19,2	19,2	19,2	19,2	18,4	18,4	18,5
	100	17,7	17,7	17,3	17,7	17,7	17,7	17,7	17,7	17,7	15,7	16,2	16,7
	150	15,8	15,8	15,8	15,8	15,8	15,8	15,8	15,8	15,8	13,9	14,8	15,5
	200	14,0	14,0	14,0	14,0	14,0	14,0	14,0	14,0	14,0	12,6	13,7	14,0
	250	12,1	12,1	12,1	12,1	12,1	12,1	12,1	12,1	12,1	11,7	12,1	12,1
	300	10,2	10,2	10,2	10,2	10,2	10,2	10,2	10,2	10,1	10,2	10,2	10,2
	350	8,4	8,4	8,4	8,4	8,4	8,4	8,4	8,4	8,4	8,4	8,4	8,4
	400	6,5			6,5		6,5	6,5	6,5	6,5	6,5	6,5	6,5
	425	5,6			5,6		5,6	5,6	5,6	5,6	5,6	5,6	5,6
	450	4,7			4,7		4,7	4,7	4,7	4,7	4,7	4,7	4,7
	500	2,8			2,8		2,8	2,8	2,8	2,8	2,8	2,8	2,8
	525	1,9			1,9		1,9	1,9	1,9	1,9	1,9	1,9	1,9
	540												
	600												
	650												
700													
750													
800													
	SHELL TEST	29,4	30,0	27,6	27,6	30,0	30,0	30,0	30,0	30,0	28,5	28,5	28,5
	SEAT TEST	21,6	22,0	20,2	20,2	22,0	22,0	22,0	22,0	22,0	20,9	20,9	20,9
300 (PN 50)	- 29 to 38	51,1	51,7	47,9	47,9	51,7	51,7	51,7	51,7	51,7	49,6	49,6	49,6
	50	50,1	51,7	47,3	47,6	51,7	51,1	51,2	51,7	51,7	47,8	48,1	48,4
	100	46,4	51,5	45,1	46,6	51,5	48,8	49,0	51,5	51,5	40,9	42,2	43,5
	150	45,2	50,2	44,0	45,0	50,2	46,4	46,6	50,2	50,2	36,3	38,5	40,5
	200	43,8	48,8	42,7	44,2	48,8	45,5	44,8	48,8	48,8	32,8	35,7	38,4
	250	41,7	46,3	40,6	43,1	46,3	44,5	44,2	46,3	46,3	30,5	33,4	36,2
	300	38,7	42,4	37,7	42,0	42,4	42,4	42,4	42,4	42,4	29,1	31,6	34,4
	350	37,0	40,2	36,0	40,2	40,2	40,2	40,2	40,2	40,2	28,1	30,4	32,9
	400	34,5	34,5		36,6	36,6	36,6	36,6	36,6	36,6	27,7	29,1	31,8
	425	28,8	28,8		35,1	35,1	35,1	35,1	34,5	35,1	27,2	28,7	31,5
	450	20,0	20,0		33,8	33,8	33,8	33,8	30,9	33,8	26,9	28,1	30,8
	500	8,8	8,8		24,1	27,1	27,8	27,8	20,3	27,5	26,1	26,8	27,8
	525	5,2	5,2		15,0	18,8	23,0	21,9	15,4	22,6	23,9	26,3	25,8
	540				10,7	13,9	12,8	16,4	11,7	17,0	21,8	25,0	25,0
	600						5,9	7,6	6,5	7,2	16,7	21,4	21,4
	650								3,0	3,5	10,5	14,1	11,6
700										6,0	9,9	6,7	
750										3,7	5,9	4,0	
800										2,1	3,5	2,6	
	SHELL TEST	76,7	77,6	71,9	71,9	77,6	77,6	77,6	77,6	77,6	74,4	74,4	74,4
	SEAT TEST	56,2	56,9	52,7	52,7	56,9	56,9	56,9	56,9	56,9	54,6	54,6	54,6
600 (PN 100)	- 29 to 38	102,1	103,4	95,7	95,8	103,4	103,4	103,4	103,4	103,4	99,2	99,3	99,3
	50	100,2	103,4	94,6	95,3	103,4	102,3	102,4	103,4	103,4	95,7	96,3	96,8
	100	92,8	103,1	90,2	93,2	103,1	97,5	98,1	103,1	103,1	81,8	84,4	86,9
	150	90,5	100,4	87,9	89,8	100,4	92,7	93,3	100,4	100,4	72,7	77,0	81,0
	200	87,6	97,6	85,4	88,4	97,6	91,0	89,7	97,6	97,6	65,5	71,3	76,8
	250	83,4	92,7	81,2	86,2	92,7	88,9	88,4	92,7	92,7	61,1	66,8	72,4
	300	77,5	84,9	75,4	84,1	84,9	84,9	84,9	84,9	84,9	58,1	63,3	68,9
	350	73,9	80,5	71,9	80,5	80,5	80,5	80,5	80,5	80,5	56,1	60,8	65,8
	400	69,0	69,0		73,2	73,2	73,2	73,2	73,2	73,2	54,9	58,2	63,5
	425	57,5	57,5		70,2	70,2	70,2	70,2	69,0	70,2	54,3	57,3	62,9
	450	40,1	40,1		67,6	67,6	67,6	67,6	61,8	67,6	53,7	56,2	61,5
	500	17,6	17,6		48,1	54,1	55,6	55,6	40,5	55,0	52,1	53,7	55,6
	525	10,4	10,4		30,1	37,6	40,5	43,8	30,8	45,2	47,8	52,6	51,6
	540	6,5	6,5		21,4	27,9	25,5	32,7	23,4	34,0	43,6	49,9	49,9
	600						11,8	15,3	13,1	14,4	33,4	42,9	42,9
	650						4,6	7,3	6,0	7,0	21,0	28,2	23,2
700										12,0	19,9	13,5	
750										7,3	11,0	8,0	
800										4,1	7,0	5,2	
	SHELL TEST	153,2	155,1	143,6	143,7	155,1	155,1	155,1	155,1	155,1	148,8	149,0	149,0
	SEAT TEST	112,3	113,7	105,3	105,4	113,7	113,7	113,7	113,7	113,7	109,1	109,2	109,2

NOTES

- (a) Permissible, but not recommended for prolonged usage above 427 °C (800 °F)
- (b) Not to be used over 343 °C (650 °F)
- (c) Permissible, but not recommended for prolonged usage above 454 °C (850 °F)
- (d) Permissible, but not recommended for prolonged usage above 593 °C (1100 °F)
- (e) Not to be used over 427 °C (800 °F)

- (f) Not to be used over 454 °C (850 °F)
- (g) At temperature over 538 °C (1000 °F), use only when carbon content is 0,04 or higher
- (h) Permissible, but not recommended for prolonged usage above 468 °C (875 °F)
- (j) Not to be used over 538 °C (1000 °F)
- (m) Not to be used over 593 °C (1100 °F)

All data, subject to technical changes, are only for information and not for official use.

PRESSURE-TEMPERATURE RATINGS ASME B16.34



MATERIALS		WCB(a)	WCC(a) LCC(b) LC2(b) LC3(b)	LCB(b)	WC1(h) LC1(b)	WC4(j) WC5	WC6(m)	WC9(m)	C5	C12	CF3(e) CF8(g)	CF8M(g) CF3M(f)	CF8C(g)
CLASS	TEMPERATURE °C	Working pressure (bars)											
900 (PN 150)	- 29 to 38	153,2	155,2	143,6	143,6	155,2	155,1	155,1	155,2	155,2	148,9	148,9	148,9
	50	150,2	155,2	141,9	142,9	155,2	153,4	153,6	155,2	155,2	143,5	144,4	144,4
	100	139,1	154,6	135,3	139,8	154,6	146,3	147,1	154,6	154,6	122,6	126,6	130,4
	150	135,7	150,6	131,9	134,9	150,6	139,1	139,9	150,6	150,6	109,0	115,5	121,5
	200	131,5	146,4	128,0	132,6	146,4	136,4	134,5	146,4	146,4	98,3	107,0	115,3
	250	125,2	139,0	121,8	129,2	139,0	133,4	132,7	139,0	139,0	91,6	100,2	108,6
	300	116,2	127,3	113,1	126,1	127,3	127,3	127,3	127,3	127,3	87,2	94,9	103,3
	350	110,9	120,7	107,9	120,7	120,7	120,7	120,7	120,7	120,7	84,2	91,3	98,7
	400	103,5	103,5		109,8	109,8	109,8	109,8	109,8	109,8	82,4	87,3	95,3
	425	86,3	86,3		105,3	105,3	105,3	105,3	105,3	105,3	81,5	86,0	94,4
	450	60,1	60,1		101,4	101,4	101,4	101,4	92,7	101,4	80,6	84,2	92,3
	500	26,4	26,4		72,2	81,2	83,4	83,4	60,8	82,5	78,2	80,5	83,4
	525	15,5	15,5		45,1	56,4	60,8	65,8	46,3	67,8	71,6	78,9	77,4
	540	9,8	9,8		32,1	41,8	38,3	49,1	35	50,9	65,4	74,9	74,9
	600						17,6	22,9	19,6	21,5	50,1	64,3	64,3
	650						7,0	11,0	9,0	10,4	31,6	42,4	34,7
	700										17,9	29,8	20,2
	750										11,0	17,6	12,1
	800										6,2	10,5	7,5
		SHELL TEST	229,8	232,8	215,4	215,4	232,8	232,7	232,7	232,8	232,8	223,4	223,4
	SEAT TEST	168,5	170,7	158,0	158,0	170,7	170,6	170,6	170,7	170,7	163,8	163,8	163,8
1500 (PN 250)	- 29 to 38	255,3	258,6	239,4	239,4	258,6	258,6	258,6	258,6	258,6	248,1	248,1	248,2
	50	250,4	258,6	236,5	238,2	258,6	255,7	256	258,6	258,6	239,2	240,6	241,9
	100	231,9	257,7	225,5	233,0	257,7	243,8	242,2	257,7	257,7	204,4	211,0	217,3
	150	226,1	251,0	219,8	224,8	251,0	231,9	233,2	251,0	251,0	181,7	192,5	202,5
	200	219,1	243,9	213,4	221,0	243,9	227,4	224,2	243,9	243,9	163,8	178,4	192,1
	250	208,6	231,7	202,9	215,4	231,7	222,3	221,1	231,7	231,7	152,7	166,9	181,0
	300	193,7	212,1	188,5	210,1	212,1	212,1	212,1	212,1	212,1	145,3	158,1	172,2
	350	184,8	201,2	179,8	201,1	201,2	201,2	201,2	201,2	201,2	140,3	152,1	164,5
	400	172,5	172,5		182,9	182,9	182,9	182,9	182,9	182,9	137,3	145,6	158,8
	425	143,8	100,2		175,5	175,5	175,5	175,5	172,5	175,5	135,8	143,3	157,3
	450	100,2	100,2		169,0	169,0	169,0	169,0	154,5	169,9	134,3	140,4	153,8
	500	44,0	44,0		120,3	135,3	139,0	139,0	101,3	137,5	130,3	134,1	139,0
	525	16,3	25,9		75,2	94,0	101,3	109,6	77,1	113	119,4	131,5	129,0
	540	16,3	16,3		53,5	69,7	63,8	81,8	58,4	84,9	109,1	124,8	124,8
	600						29,4	38,2	32,6	35,9	83,6	107,2	107,2
	650						11,6	18,3	15,0	17,4	52,6	70,6	57,9
	700										29,9	49,7	33,7
	750										18,3	29,4	20,1
	800										10,3	17,5	13,1
		SHELL TEST	383,0	387,9	359,1	359,1	387,9	387,9	387,9	387,9	387,9	372,2	372,2
	SEAT TEST	280,8	284,5	263,3	263,3	284,5	284,5	284,5	284,5	284,5	272,9	272,9	273,0
2500 (PN 420)	- 29 to 38	425,5	431,0	398,9	399,0	431,0	431,0	431,0	431,0	431,0	413,5	413,6	413,6
	50	417,3	431,0	393,7	397,1	431,0	426,2	426,7	430,9	430,9	398,6	401,0	403,2
	100	386,5	429,5	388,3	429,5	429,5	406,4	109,7	429,5	429,5	374,7	351,7	362,2
	150	376,9	419,3	366,3	374,6	418,3	386,4	388,6	418,3	418,3	302,8	320,9	337,5
	200	365,2	406,6	355,6	368,3	406,6	379,0	373,7	406,6	406,6	273,0	297,3	320,2
	250	347,7	386,1	338,2	359,0	386,1	370,6	368,5	386,1	386,1	254,5	278,2	301,7
	300	322,8	353,5	314,2	350,2	353,5	353,5	353,5	353,5	353,5	242,1	263,6	287,0
	350	308,0	335,3	299,7	335,2	335,3	335,3	335,3	335,3	335,3	233,8	253,8	274,2
	400	287,5	287,5		304,9	304,9	304,9	304,9	304,9	304,9	228,9	242,6	264,7
	425	239,6	239,6		292,5	292,5	292,5	292,5	287,5	292,5	226,4	238,9	262,2
	450	166,9	166,9		281,7	281,7	281,7	281,7	257,6	281,7	223,9	234,0	256,3
	500	73,3	73,3		200,6	225,4	231,6	231,6	168,9	229,1	217,2	223,6	231,6
	525	43,2	43,2		125,4	156,6	168,9	182,7	128,5	188,3	199,0	214,9	214,9
	540	27,2	27,2		89,2	116,1	106,4	136,4	97,3	141,5	181,8	208,0	208,0
	600						49,0	63,6	54,4	59,8	139,3	178,6	178,6
	650						19,3	30,4	25,1	29,0	87,6	117,1	96,5
	700										49,8	82,9	56,1
	750										30,4	49,0	33,5
	800										17,1	29,2	21,9
		SHELL TEST	638,3	646,5	598,4	398,5	646,5	646,5	646,5	646,5	646,5	620,3	620,4
	SEAT TEST	468,1	474,1	438,8	438,1	474,1	474,1	474,1	474,1	474,1	454,9	455,0	455,0

NOTES

- (a) Permissible, but not recommended for prolonged usage above 427 °C (800 °F)
- (b) Not to be used over 343 °C (650 °F)
- (c) Permissible, but not recommended for prolonged usage above 454 °C (850 °F)
- (d) Permissible, but not recommended for prolonged usage above 593 °C (1100 °F)
- (e) Not to be used over 427 °C (800 °F)
- (f) Not to be used over 454 °C (850 °F)
- (g) At temperature over 538 °C (1000 °F), use only when carbon content is 0,04 or higher
- (h) Permissible, but not recommended for prolonged usage above 468 °C (875 °F)
- (i) Not to be used over 538 °C (1000 °F)
- (m) Not to be used over 593 °C (1100 °F)

All data, subject to technical changes, are only for information and not for official use.

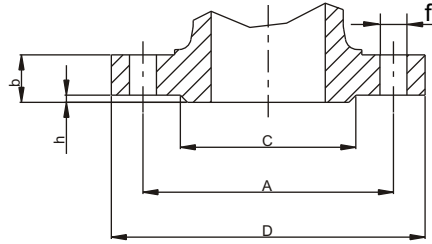

DN = Nominal pipe size
 D = Outside diameter of flange
 b = Thickness of flange min.
 C = Diameter of hub
 h = Height of raised face
 N = Number of bolt holes
 f = Diameter of bolt holes
 A = Diameter of bolt circle

PN	DN	D	b	C	h	N°	f	A		PN	DN	D	b	C	h	N°	f	A
6	10	75	12	35	2	4	11	50		6	100	210	16	148	3	4	18	170
10-16	10	90	14	40	2	4	14	60		10-16	100	220	20	158	3	8	18	180
25-40	10	90	16	40	2	4	14	60		25-40	100	235	24	162	3	8	22	190
64-100	10	100	20	40	2	4	14	70		64	100	250	30	162	3	8	26	200
160	10	100	20	40	2	4	15	70		160	100	265	40	162	3	8	30	210
250	10	125	24	40	2	4	18	85		250	100	300	54	162	3	8	34	235
6	15	80	12	40	2	4	11	55		100	125	265	36	162	3	8	30	210
10-16	15	95	14	45	2	4	14	65		6	125	240	18	178	3	8	18	200
25-40	15	95	16	45	2	4	14	65		10-16	125	250	22	188	3	8	18	210
64-100	15	105	20	45	2	4	14	75		25-40	125	270	26	188	3	8	26	220
160	15	105	20	45	2	4	15	75		64	125	295	34	188	3	8	30	240
250	15	130	26	45	2	4	18,5	90		100	125	315	40	188	3	8	33	250
6	20	90	14	50	2	4	11	65		160	125	315	44	188	3	8	33	250
10-16	20	105	16	58	2	4	14	75		250	125	340	60	188	3	12	41	275
25-40	20	105	18	58	2	4	14	75		6	150	265	18	202	3	8	18	225
64-100	20	130	24	58	2	4	18	90		10-16	150	285	22	212	3	8	22	240
6	25	100	14	60	2	4	11	75		25-40	150	300	28	218	3	8	26	250
10-16	25	115	16	68	2	4	14	85		64	150	345	36	218	3	8	33	280
25-40	25	115	18	68	2	4	14	85		100	150	355	44	218	3	12	33	290
64-100	25	140	24	68	2	4	18	100		160	150	355	50	218	3	12	33	290
160	25	140	24	68	2	4	18	100		250	150	390	68	218	3	12	48	320
250	25	150	28	68	2	4	19	105		6	175	295	20	232	3	8	18	255
6	32	120	14	70	2	4	14	90		10-16	175	315	24	242	3	8	22	270
10-16	32	140	16	78	2	4	18	100		25	175	330	28	248	3	12	26	280
25-40	32	140	18	78	2	4	18	100		40	175	350	32	260	3	12	30	295
64-100	32	155	24	78	2	4	22	110		64	175	375	40	260	3	12	33	310
6	40	130	14	80	3	4	14	100		100	175	385	48	260	3	12	33	320
10-16	40	150	16	88	3	4	18	110		160	175	390	54	260	3	12	36	320
25-40	40	150	18	88	3	4	18	110		250	175	430	74	260	3	12	50	355
64-100	40	170	26	85	3	4	22	125		6	200	320	20	258	3	8	18	280
160	40	170	28	88	3	4	22	125		10	200	340	24	268	3	8	22	295
250	40	185	34	88	3	4	25	135		16	200	340	24	268	3	12	22	295
6	50	140	14	90	3	4	14	110		25	200	360	30	278	3	12	26	310
10-16	50	165	18	102	3	4	18	125		40	200	375	34	285	3	12	30	320
25-40	50	165	20	102	3	4	18	125		64	200	415	42	285	3	12	36	345
64	50	180	26	102	3	4	22	135		100	200	430	52	285	3	12	36	360
100	50	195	28	102	3	4	26	145		160	200	430	60	285	3	12	36	360
160	50	195	30	102	3	4	26	145		250	200	485	82	285	3	12	57	400
250	50	200	38	102	3	5	26	150		6	250	375	22	312	3	12	18	335
6	65	160	14	110	3	4	14	130		10	250	395	26	320	3	12	22	350
10-16	65	185	18	122	3	4	18	145		16	250	405	26	320	3	12	26	355
25-40	65	185	22	122	3	8	18	145		25	250	425	32	335	3	12	30	370
64	65	205	26	120	3	8	22	160		40	250	450	38	345	3	12	33	385
100	65	220	30	120	3	8	26	170		64	250	470	46	345	3	12	36	400
160	65	220	34	122	3	8	26	180		100	250	505	60	345	3	12	39	430
250	65	230	42	122	3	8	30	180		160	250	515	68	345	3	12	42	430
6	80	190	16	128	3	4	18	150		250	250	585	100	345	3	16	72	490
10	80	200	20	138	3	8	18	160		6	300	440	22	365	4	12	22	395
16	80	200	20	138	3	8	18	160		10	300	445	26	370	4	12	22	400
25-40	80	200	24	138	3	8	18	160		16	300	460	28	378	4	12	26	410
64	80	215	28	138	3	8	22	170		25	300	485	34	390	4	16	30	430
100	80	230	32	138	3	8	24	180		40	300	515	42	410	4	16	33	450
160	80	230	36	138	3	8	40	180		64	300	530	52	410	4	16	36	460
250	80	255	46	138	3	8	31	200		100	300	585	68	410	4	16	42	500
										160	300	585	78	410	4	16	42	500
										250	300	690	120	410	4	16	90	590

All dimensions in mm (except where differently indicated)

All data, subject to technical changes, are only for information and not for official use.

VALVOSIDER s.r.l. - Via S. Rocco, 2 - P.O. BOX 76 - 13011 Borgosesia (VC) - Italy
 Phone: +39016322991 - Fax: +39016321537 - www.valvosider.com - e-mail: valvo@valvosider.com

DIN FLANGES DIMENSIONS

DN 350 ÷ DN 1200

VALVOSIDER
MANUFACTURER OF VALVES

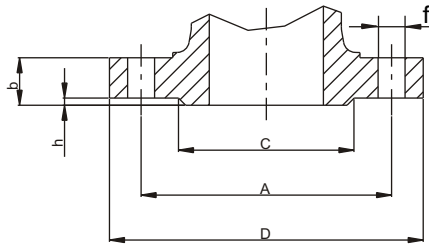

DN = Nominal pipe size
D = Outside diameter of flange
b = Thickness of flange min.
C = Diameter of hub
h = Height of raised face
N = Number of bolt holes
f = Diameter of bolt holes
A = Diameter of bolt circle

PN	DN	D	b	C	h	N°	f	A		PN	DN	D	b	C	h	N°	f	A
6	350	490	22	415	4	12	22	445		6	700	860	24	775	5	24	25	810
10	350	505	26	430	4	16	22	460		10	700	895	30	800	5	24	30	840
16	350	520	30	438	4	16	26	470		16	700	910	42	795	5	24	36	840
25	350	555	38	450	4	16	33	490		25	700	960	50	820	5	24	42	875
40	350	580	46	465	4	16	36	510		40	700	995	64	840	5	24	48	900
64	350	600	56	465	4	16	39	525		64	700	1045	84	840	5	24	56	935
100	350	655	74	465	4	16	48	560		100	700	1145	120	840	5	24	70	1020
6	400	540	22	465	4	16	22	495		6	800	975	24	880	5	24	30	920
10	400	565	26	482	4	16	26	515		10	800	1015	32	905	5	24	33	950
16	400	580	32	490	4	16	30	525		16	800	1025	42	900	5	24	39	950
25	400	620	40	505	4	16	36	550		25	800	1085	64	930	5	24	48	990
40	400	660	50	535	4	16	39	585		40	800	1165	72	960	5	24	62	1050
64	400	670	60	535	4	16	42	585		64	800	1165	92	960	5	24	62	1050
100	400	715	78	535	4	16	48	620		100	800	n.a	n.a	n.a	n.a	n.a	n.a	n.a
6	450	595	22	520	4	16	22	550		6	900	1075	26	980	5	24	30	1020
10	450	615	26	532	4	20	26	565		10	900	1115	34	1005	5	28	33	1050
16	450	640	32	550	4	20	30	585		16	900	1125	44	1000	5	28	39	1050
25	450	670	40	555	4	20	36	600		25	900	1185	68	1030	5	28	48	1090
40	450	685	50	560	4	20	39	610		40	900	1250	78	1070	5	28	56	1140
64	450	715	64	560	4	20	42	630		64	900	1285	98	1070	5	28	62	1170
100	450	770	86	560	4	20	48	675		100	900	n.a	n.a	n.a	n.a	n.a	n.a	n.a
6	500	645	24	570	4	20	22	600		6	1000	1175	26	1080	5	28	30	1120
10	500	670	28	585	4	20	26	620		10	1000	1230	34	1110	5	28	36	1160
16	500	715	36	610	4	20	33	650		16	1000	1255	46	1115	5	28	42	1170
25	500	730	44	615	4	20	36	660		25	1000	1320	62	1140	5	28	56	1210
40	500	755	52	615	4	20	42	670		40	1000	1360	80	1180	5	28	56	1250
64	500	800	68	615	4	20	48	705		64	1000	1415	108	1180	5	28	70	1290
100	500	870	94	615	4	20	56	760		100	1000	n.a	n.a	n.a	n.a	n.a	n.a	n.a
6	600	755	24	670	5	20	26	705		6	1200	1405	28	1295	5	32	33	1340
10	600	780	28	685	5	20	30	725		10	1200	1455	38	1330	5	32	39	1380
16	600	840	40	725	5	20	36	770		16	1200	1485	52	1330	5	32	48	1390
25	600	845	46	720	5	20	39	770		25	1200	1530	70	1350	5	32	56	1420
40	600	890	54	735	5	20	48	795		40	1200	1575	88	1380	5	32	62	1460
64	600	930	76	735	5	20	56	820		64	1200	1665	126	1380	5	32	78	1530
100	600	990	104	735	5	20	62	875		100	1200	n.a	n.a	n.a	n.a	n.a	n.a	n.a

FLANGES - TYPES OF CONTACT SURFACES - DIN 2526

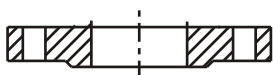

FLANGES WITH RAISED FACE



FLANGES WITHOUT RAISED FACE

Type A - Contact face without stipulation

Type B - Contact face $R_z = 160$, turned (not finer than 40 micron)

Type C - Raised face $R_z = 160$ (not finer than 40 micron), turned

Type D - Raised face $R_z = 40$, turned

Type E - Raised face $R_z = 16$, turned

NOMINAL ROUGHNESS GRADES (R_a)

R_a (μm)	R_z (μm)
1.6	16
3.2	25
6.3	40
12.5	100
25	160

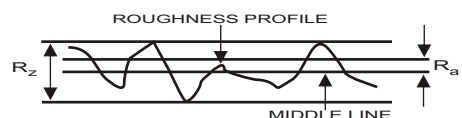

All dimensions in mm (except where differently indicated)

All data, subject to technical changes, are only for information and not for official use.

VALVOSIDER s.r.l. - Via S. Rocco, 2 - P.O. BOX 76 - 13011 Borgosesia (VC) - Italy
Phone: +39016322991 - Fax: +39016321537 - www.valvosider.com - e-mail: valvo@valvosider.com

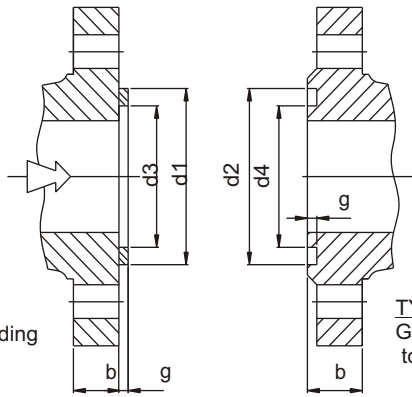

TYPE F -
Tongue according
to DIN 2512

TYPE N -
Groove according
to DIN 2512

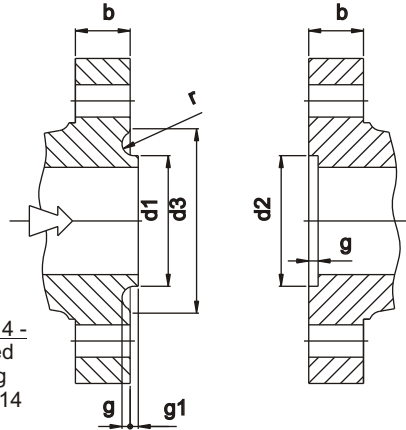

TYPE V 14 -
Male-facing
according
to DIN 2514

TYPE R 14 -
Female-facing
according
to DIN 2514

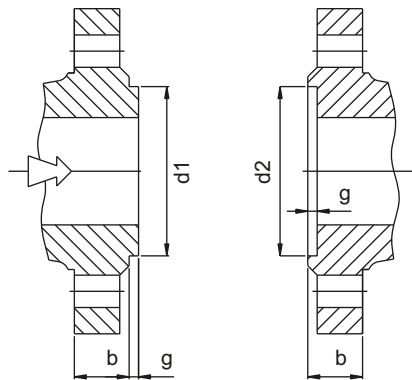

TYPE V 13 -
Male-facing
according
to DIN 2513

TYPE R 13 -
Female-facing
according
to DIN 2513

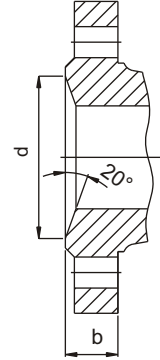

TYPE L - Recess for lenticular seal
according to DIN 2696

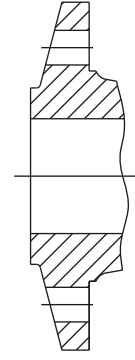

TYPE M - Bevel for diaphragm
seal welding according to
DIN 2695

DIMENSIONS OF FACING

DN	DIN 2513					DIN 2512									DN	DIN 2514							LENTICULAR SEAL DIN 2696		DN
	PN ≤ 6		PN ≥ 10			g	PN ≤ 6				PN ≥ 10					g	PN 10 ÷ 40					PN 64 : 250	d		
	d ₁	d ₂	d ₁	d ₂	d ₃		d ₄	d ₁	d ₂	d ₃	d ₄	d ₁	d ₂	d ₃			g	g ₁	r						
10	30	31	34	35	4	30	31	22	21	34	35	24	23	4	10	-	-	-	-	-	-	18	10		
15	35	36	39	40	4	35	36	27	26	39	40	29	28	4	15	-	-	-	-	-	-	24	15		
20	42	43	50	51	4	42	43	32	31	50	51	36	35	4	20	35	36	51	4	2	2,5	30	20		
25	49	50	57	58	4	49	50	39	38	57	58	43	42	4	25	42	43	58	4	2	2,5	35	25		
32	61	62	65	66	4	61	62	49	48	65	66	51	50	4	32	50	51	66	4	2	2,5	43	32		
40	68	69	75	76	4	68	69	56	55	75	76	61	60	4	40	60	61	76	4	2	2,5	51	40		
50	81	82	87	88	4	81	82	69	68	87	88	73	72	4	50	72	73	88	4	2	2,5	63	50		
65	101	102	109	110	4	101	102	89	88	109	110	95	94	4	65	94	95	110	4	2	2,5	85	65		
80	117	118	120	121	4	117	118	103	102	120	121	106	105	4	80	105	106	121	4	2	2,5	97	80		
100	137	138	149	150	4,5	137	138	123	122	149	150	129	128	4,5	100	128	129	150	4,5	2,5	3	124	100		
125	165	166	175	176	4,5	165	166	149	148	175	176	155	154	4,5	125	154	155	176	4,5	2,5	3	153	125		
150	192	193	203	204	4,5	192	193	176	175	203	204	183	182	4,5	150	182	183	204	4,5	2,5	3	181	150		
175	222	223	233	234	4,5	222	223	206	205	233	234	213	212	4,5	175	212	213	234	4,5	2,5	3	218	175		
200	249	250	259	260	4,5	249	250	231	230	259	260	239	238	4,5	200	238	239	260	4,5	2,5	3	243	200		
250	304	305	312	313	4,5	304	305	286	285	312	313	292	291	4,5	250	291	292	313	4,5	2,5	3	298	250		
300	354	355	363	364	4,5	354	355	336	335	363	364	343	342	4,5	300	342	343	364	4,5	2,5	3	345	300		
350	401	402	421	422	5	401	402	381	380	421	422	395	394	5	350	394	395	422	5	3	3,5	394	350		
400	451	452	473	474	5	451	452	431	430	473	474	447	446	5	400	446	447	474	5	3	3,5	445	400		
450	505	506	523	524	5	505	506	481	480	523	524	497	496	5	450	496	497	524	5	3	3,5		450		
500	555	556	575	576	5	555	556	531	530	575	576	549	548	5	500	548	549	576	5	3	3,5		500		
600	655	656	675	676	5	655	656	631	630	675	676	649	648	5	600	648	649	676	5	3	3,5		600		
700	760	761	777	778	5	760	761	736	735	777	778	751	750	5	700	750	751	778	5	3	3,5		700		
800	865	866	882	883	5	865	866	841	840	882	883	856	855	5	800	855	856	883	5	3	3,5		800		
900	965	966	987	988	5	965	966	941	940	987	988	961	960	5	900	960	961	988	5	3	3,5		900		
1000	1062	1063	1091	1092	6	1062	1063	1036	1035	1091	1092	1061	1060	6	1000	1060	1061	1092	6	3	4		1000		

All dimensions in mm (except where differently indicated)

All data, subject to technical changes, are only for information and not for official use.

VALVE WELDING ENDS - DIN 3239

Part 1 - Butt ends | Part 2 - Socket ends

VALVOSIDER
MANUFACTURER OF VALVES

Nominal size DN	Butt Welding ends for pipes of							
	series 1 (up to PN 40)	series 2 (PN 63)	series 3 (PN 100)	series 4 (PN 160)	series 5 (PN 250)	series 6 *) (PN 320)	series 7 (PN 400)	series 8 (PN 630)
10	d1	Use series 4 welding ends		20	Use series 6 welding ends	20	20	24
	d2	Use series 4 welding ends		18	Use series 6 welding ends	18	18	22
	d3	Use series 4 welding ends		17,2	Use series 6 welding ends	17,2	17,2	21,3
	d _p	Use series 4 welding ends		13	Use series 6 welding ends	12	10	11,5
	s	Use series 4 welding ends		2,0	Use series 6 welding ends	2,6	3,6	5,0
15	d1	Use series 4 welding ends		24	24	24	31	37
	d2	Use series 4 welding ends		22	22	22	28	34
	d3	Use series 4 welding ends		21,3	21,3	21,3	26,9	33,7
	d _p	Use series 4 welding ends		17	16	15	17	18,5
	s	Use series 4 welding ends		2,0	2,6	3,2	5,0	8,0
20	d1	31	--	--	--	--	--	--
	d2	28	--	--	--	--	--	--
	d3	26,9	--	--	--	--	--	--
	d _p	22	--	--	--	--	--	--
	s	2,3	--	--	--	--	--	--
25	d1	Use series 3 welding ends		37	39	39	48	54
	d2	Use series 3 welding ends		34	34	35	44	49
	d3	Use series 3 welding ends		33,7	33,7	33,7	42,4	48,3
	d _p	Use series 3 welding ends		28,5	27	20,5	24	25
	s	Use series 3 welding ends		2,6	3,2	3,6	5,0	7,1
40	d1	Use series 3 welding ends		54	54	54	67	67
	d2	Use series 3 welding ends		49	49	49	61	77
	d3	Use series 3 welding ends		48,3	48,3	48,3	60,3	76,1
	d _p	Use series 3 welding ends		43	41	38,5	40	43,5
	s	Use series 3 welding ends		2,6	3,6	5,0	6,3	11,0
50	d1	Use series 3 welding ends		67	67	67	83	96
	d2	Use series 3 welding ends		61	61	61	77	90
	d3	Use series 3 welding ends		60,3	60,3	60,3	76,1	88,9
	d _p	Use series 3 welding ends		54	52,5	45	59,5	51,5
	s	Use series 3 welding ends		3,2	4,0	8,0	8,8	14,2
65	d1	Use series 3 welding ends		83	83	83	96	121
	d2	Use series 3 welding ends		77	77	77	90	115
	d3	Use series 3 welding ends		76,1	76,1	76,1	88,9	114,3
	d _p	Use series 3 welding ends		69	85	59,5	68	81
	s	Use series 3 welding ends		3,6	5,6	8,8	11,0	17,5
80	d1	Use series 3 welding ends		96	96	121	121	121
	d2	Use series 3 welding ends		90	90	115	115	115
	d3	Use series 3 welding ends		88,9	88,9	114,3	114,3	114,3
	d _p	Use series 3 welding ends		81	76,5	93	87,5	81
	s	Use series 3 welding ends		4,0	6,3	11,0	14,2	17,5
100	d1	Use series 3 welding ends		121	121	121	121	--
	d2	Use series 3 welding ends		115	115	115	115	--
	d3	Use series 3 welding ends		114,3	114,3	114,3	114,3	--
	d _p	Use series 3 welding ends		104	96,5	104	96,5	--
	s	Use series 3 welding ends		5,0	8,0	5,0	8,0	--
125	d1	Use series 2 welding ends	147	147	147	147	147	--
	d2		141	141	141	141	141	--
	d3		139,7	139,7	139,7	139,7	139,7	--
	d _p		130,5	127	120,5	130,5	127	--
	s		4,5	6,3	10,0	4,5	6,3	--
150	d1	Use series 2 welding ends	176	176	176	176	176	--
	d2		170	170	170	170	170	--
	d3		168,3	168,3	168,3	168,3	168,3	--
	d _p		156,5	154	144,5	156,5	154	--
	s		5,6	7,1	12,5	5,6	7,1	--
200	d1	Use series 2 welding ends	228	228	228	228	228	--
	d2		222	222	222	222	222	--
	d3		219,1	219,1	219,1	219,1	219,1	--
	d _p		204,5	199,5	169	204,5	199,5	--
	s		7,1	10	16,0	7,1	10	--
250	d1	Use series 2 welding ends	282	282	282	282	282	--
	d2		276	276	276	276	276	--
	d3		273	273	273	273	273	--
	d _p		256,5	255	248,5	256,5	255	--
	s		8,0	8,8	12,5	8,0	8,8	--
300	d1	Use series 2 welding ends	331	331	331	331	331	--
	d2		325	325	325	325	325	--
	d3		323,9	323,9	323,9	323,9	323,9	--
	d _p		306,5	301	295,5	306,5	301	--
	s		8,0	11,0	14,2	8,0	11,0	--
350	d1	Use series 2 welding ends	365	365	365	365	365	--
	d2		359	359	359	359	359	--
	d3		355,6	355,6	355,6	355,6	355,6	--
	d _p		336,5	330	324	336,5	330	--
	s		8,8	12,5	16,0	8,8	12,5	--
400	d1	Use series 2 welding ends	417	417	417	417	417	--
	d2		411	411	411	411	411	--
	d3		406,4	406,4	406,4	406,4	406,4	--
	d _p		383	377	371	383	377	--
	s		11	14,2	18,8	11	14,2	--
500	d1	Use series 2 welding ends	518	518	518	518	518	--
	d2		512	512	512	512	512	--
	d3		508	508	508	508	508	--
	d _p		478	472	466	478	472	--
	s		14,2	18,8	25,4	14,2	18,8	--

WELDING SOCKET CONNECTIONS

DIN 3239 - Part 2

da = min. socket ext. diameter
d1 = socket bore diameter
t = depth of socket

DIN 3239 - Part 1

Type 1

S = wall thickness
d2 = pipe external diameter
dp = d2 - 2S (pipe int. diameter)

1) d1 is the maximum permissible major diameter, generally applicable for steel castings or malleable cast iron components suitable for welding.
2) d3 is the major diameter of the associated series 1 steel pipe as specified in ISO 4200 - 1985.
*) Welding neck flanges are not suitable for use with piping systems rated for PN 320 and PN 630.

Nominal width DN	da min. Series			di	Associated outside diameter of pipe	t
	4	5	6			
6	17	17	17	11	10,2	10
8	21	21	22	14	13,5	10
10	24	24	26	18	17,2	10
15	29	32	34	22	21,3	10
20	35	38	41	27,5	26,9	13
25	42	46	50	34,5	33,7	13
32	52	55	59	43	42,4	13
40	57	62	68	49	48,3	13
50	71	75	83	61,5	60,3	16
65	90	100	110	77	76,1	16
80	100	120	130	90	88,9	16
100	135	150	165	115,5	114,3	20

All dimensions in mm (except where differently indicated)

All data, subject to technical changes, are only for information and not for official use.

VALVOSIDER s.r.l. - Via S. Rocco, 2 - P.O. BOX 76 - 13011 Borgosesia (VC) - Italy
Phone: +39016322991 - Fax: +39016321537 - www.valvosider.com - e-mail: valvo@valvosider.com

Designation		Chemical composition (cast analysis) (% min.)								
Name	Number	C	Si max	Mn	P max	S max	Cr	Mo	Ni	others
GP240GH	1.0619	0,18 to 0,23	0,60	0,50 to 1,20	0,030	0,020 ¹⁾	--	--	--	--
G20Mo5	1.5419	0,18 to 0,23	0,60	0,50 to 1,00	0,025	0,020 ¹⁾	--	0,40 to 0,60	--	--
G17CrMo5-5	1.7357	0,15 to 0,20	0,60	0,50 to 1,00	0,020	0,020 ¹⁾	1,00 to 1,50	0,45 to 0,65	--	--
G17CrMo9-10	1.7379	0,13 to 0,20	0,60	0,50 to 0,90	0,020	0,020 ¹⁾	2,00 to 2,50	0,90 to 1,20	--	--
GX15CrMo5	1.7365	0,12 to 0,19	0,80	0,50 to 0,80	0,025	0,025	4,00 to 6,00	0,45 to 0,65	--	--
G20Mn5	1.6220	0,17 to 0,23	0,60	1,00 to 1,60	0,020	0,020 ¹⁾	--	--	0,80 max	--
G9Ni10	1.5636	0,06 to 0,12	0,60	0,50 to 0,80	0,020	0,015	--	--	2,00 to 3,00	--
G9Ni14	1.5638	0,06 to 0,12	0,60	0,50 to 0,80	0,020	0,015	--	--	3,00 to 4,00	--
GX5CrNi19-10 2)	1.4308 2)	0,07 max	1,50	1,50	0,040	0,030	18,00 to 20,00	--	8,00 to 11,00	--
GX5CrNiNb19-11 2)	1.4552 2)	0,07 max	1,50	1,50	0,040	0,030	18,00 to 20,00	--	9,00 to 12,00	Nb: 8 x C, max: 1,00
GX5CrNiMo19-11-2 2)	1.4408 2)	0,07 max	1,50	1,50	0,040	0,030	18,00 to 20,00	2,00 to 2,50	9,00 to 12,00	--
GX5CrNiMoNb19-11-2 2)	1.4581 2)	0,07 max	1,50	1,50	0,040	0,030	18,00 to 20,00	2,00 to 2,50	9,00 to 12,00	Nb: 8 x C, max: 1,00
GX2CrNiMoN22-5-3	1.4470	0,03 max	1,00	2,00	0,035	0,025	21,00 to 23,00	2,50 to 3,50	4,50 to 6,50	N: 0,12 to 0,20

1) For castings of ruling thickness <28 mm, % 0,030 S is permitted

2) It should be pointed out that the suggested chemical composition ranges of these alloyed corrosion resistant steel grades are rather large. According to the final destination (high temperature/low temperature, etc...) it may be advisable for the founder to aim for narrower ranges for different elements in order to achieve the most suitable structures.

MECHANICAL PROPERTIES

Designation		Heat treatment °C		Test at room temperature				Test at elevated temperature								
Name	Number	Symbol 2)	Normalizing (+ N) or Quenching (+ Q) 1)	Tempering (+T)	Tensile test			Impact test	Tensile test							
					Rp _{0,2} Mpa *) min	Rm Mpa *)	A % min		KV J min.	Rp _{0,2} Mpa *) min at °C						
									100°	200°	300°	350°	400°	450°	500°	550°
GP240GH	1.0619	+ N + QT	900 to 980 890 to 980	-- 600 to 700	240	420 to 600	22	27	210	175	145	135	130	125	--	--
G20Mo5	1.5419	+ QT	920 to 980	650 to 730	245	440 to 590	22	27	--	190	165	155	150	145	135	--
G17CrMo5-5	1.7357	+ QT	920 to 960	680 to 730	315	490 to 690	20	27	--	250	230	215	200	190	175	160
G17CrMo9-10	1.7379	+ QT	930 to 970	680 to 740	400	590 to 740	18	40	--	355	345	330	315	305	280	240
GX15CrMo5	1.7365	+ QT	930 to 990	680 to 730	420	630 to 760	16	27	--	390	380	--	370	--	305	250

1) +Q means quenching media: air or liquid. +T = tempering. +N = normalizing

2) If there are alternative specifications for heat treatment, the requested alternative shall be indicated on the order, e.g.: GP240GH +QT1 or 1.0619 +QT1

*) 1 Mpa = 1N/mm²

Designation		Heat treatment °C		Test at room temperature			Impact test		
Name	Number	Symbol 1)	Quenching	Tempering	Tensile strength			KV J min.	At °C
					Rp _{0,2} Mpa *) min	Rm Mpa *)	A % min		
G20Mn5	1.6220	+ N + QT	900 to 980 900 to 940	-- 610 to 660	300	480 to 620	20	27	-30
G9Ni10	1.5636	+ QT	830 to 890	600 to 650	280	480 to 630	24	27	-70
G9Ni14	1.5638	+ QT	820 to 900	590 to 650	360	500 to 650	20	27	-90

1) +Q: quenching in water. +T = tempering. +N = normalizing.

*) 1 Mpa = 1 N/mm²

Designation		Heat treatment		Test at room temperature				Test at elevated temperature							
Name	Number	+ AT 1)	°C	Tensile test			Impact test	Tensile test							
				Rp _{1,0} 5) Mpa *) min	Rm Mpa *)	A % min		KV J min.	°C 8)	Rp _{1,0} 5) Mpa *) min. at °C					
									100°	200°	300°	350°	400°	500°	550°
GX5CrNi19-10	1.4308		1050 to 1150	200	440 to 640	30	60 7)	RT 7)	160	125	110	--	--	--	--
GX5CrNiNb19-11	1.4552		1050 to 1150	200	440 to 640	25	40	RT	165	145	130	--	120	110	100
GX5CrNiMo19-11-2	1.4408		1080 to 1150	210	440 to 640	30	60 7)	RT 7)	170	135	115	--	105	--	--
GX5CrNiMoNb19-11-2	1.4581		1080 to 1150	210	440 to 640	25	40	RT	185	160	145	--	130	120	115
GX2CrNiMoN22-5-3	1.4470		1120 to 1150 2) 3)	420 6)	600 to 800	20	30	RT	330 6)	280 6)	4)	--	--	--	--

1) The heat treatment for all the steel grades is +AT +QW (solution annealing + water quenching).

2) After solution annealing at high temperature, castings may be cooled down to 1040 °C to 1010 °C prior to water quenching in order to improve corrosion resistance and prevent cracks in complex shapes.

3) As far as steel castings for pressure vessel are concerned the austenitic-ferritic steel are not considered in their age hardened condition.

4) For similar reasons as those concerning note 3) the austenitic-ferritic steel have not to be used for temperatures higher than 250 °C in pressure vessel applications.

5) Rp_{0,2} may be estimated by lowering Rp_{1,0} by 25 Mpa.

6) Rp_{0,2}

7) For use at low temperature impact properties may be agreed and the following applies: Steel number 1.4308 KV J min. 60 at -196 °C.

8) RT = Room temperature. *) 1 Mpa = 1 N/mm²

All data, subject to technical changes, are only for information and not for official use.

MATERIALS EQUIVALENCE AND COMPARISON

VALVOSIDER
MANUFACTURER OF VALVES

MATERIALS EQUIVALENCE

ASTM	EN 10213	EN No.	UNS	JIS	TRADE MARK
A48-40B	EN-GJL-250	0.6025			
	EN-GJS-400-18	0.7043			
A216 WCB	GP240GH	1.0619	J03002	SCPH2	
A352 LCB	G20Mn5	1.6220	J03003	SCPL1	
A352 LC2					
A352 LC3	G9Ni14	1.5638	J31550	SCPL31	
A217 WC1	G20Mo5	1.5419	J12524	SCPH11	
A217 WC6	G17CrMo5-5	1.7357	J12072	SCPH21	
A217 WC9	GS12CrMo9-10	1.7379	J21890	SCPH32-CF	
A217 C5	GX15CrMo5	1.7365 (1.7363)	J42045	SCPH61	
A217 C12	(GX12CrMo10-1)	(1.7389)	J82090		
A351 CF3	X2CrNi19-11	1.4306	J92500	SCS19	
A351 CF3M	X2CrNiMo17-12-2	1.4409	J92800	SCS16	
A351 CF8	GX5CrNiMo19-10	1.4308	J92600	SCS13	
A351 CF8C	GX5CrNiNb19-11	1.4552	J92710		
A351 CF8M	GX5CrNiMo19-11-2	1.4408	J92900	SCS14	
A351 CF8MC	GX5CrNiMoNb19-11-2	1.4581			
A351 CG8M					
	GX2CrNiMoN22-5-3	1.4470			
A351 CK3MCuN					
A351 CN7M			N08007	SCS23	
A494 N-12MV			N10001		HASTELLOY B ®
A494 CW-12MW			N10002		HASTELLOY C ®
A494 M35-1			N04400		MONEL 400 ®
A494 CW-6MC			N06625		INCONEL 625 ®
			N08825		INCOLOY 825 ®
			S31803		SAF 2205 ®
			S31254		254 SMO ®
			S32550		FERRALIUM 255 ®

MATERIALS COMPARISON

CASTINGS			FORGINGS		
ASTM	EN 10213	EN No.	ASTM	EN 10213	EN No.
A216 WCB	GP240GH (GS-C 25N)	1.0619	A105	(C22.8)	1.0460
A352 LCB	G20Mn5	1.6220	A350 LF2		1.0437
A352 LC2					
A352 LC3	G9Ni14	1.5638	A350 LF3		1.5637
A217 WC1	G20Mo5	1.5419	A182 F1		1.5415
A217 WC6	G17CrMo5-5	1.7357	A182 F11	14CrMo4-5	1.7335
A217 WC9	GS12CrMo9-10	1.7379	A182 F22		1.7380
A217 C5	GX15CrMo5	1.7365 (1.7363)	A182 F5		1.7362
A217 CA15			A182 F6	(X20Cr13)	1.4021
A217 C12	(GX12CrMo10-1)	(1.7389)	A182 F9	(15CrMo12.1)	1.4920
A351 CF3	GX2CrNi19-11	1.4309	A182 F304L	X2CrNi19-11	1.4306
A351 CF3M	GX2CrNiMo19-11-2	1.4409	A182 F316L	X2CrNiMo17-12-2	1.4404
A351 CF8	GX5CrNi19-10	1.4308	A182 F304	X5CrNi18-10	1.4301
A351 CF8C	GX5CrNiNb19-11	1.4552	A182 F321	X6CrNiTi18-10	1.4541
A351 CF8C	GX5CrNiNb19-11	1.4552	A182 F347	X6CrNiNb18-10	1.4550
A351 CF8M	GX5CrNiMo19-11-2	1.4408	A182 F316	X5CrNiMo17-12-2	1.4401
A351 CF8MC	GX5CrNiMoNb19-11-2	1.4581	A182 F348	X6CrNiMoNb17-12-2	1.4580
A351 CG8M			A182 F317		
A351 CK3MCuN			A182 F44		
A351 CN7M			A182 F20		

BOLTS - ASME MATERIALS

BOLTS		NUTS	
B7	ASTM A193 B7	2H	ASTM A194 Gr.2H
B16	ASTM A193 B16	Gr.4	ASTM A194 Gr.4
L7	ASTM A320 L7	Gr.4	ASTM A194 Gr.4
B8M	ASTM A193 B8M	Gr.8M	ASTM A193 Gr.8M
B8	ASTM A193 B8 CL. 1	Gr.8 A	ASTM A194 Gr.8A
320 B8	ASTM A320 B8 CL.1	Gr.8 A	ASTM A194 Gr.8A
307 B	ASTM A307 Gr.B		
B8	ASTM A193 B8 CL. 1	2H	ASTM A194 Gr.2H

BOLTS - DIN MATERIALS

MATERIALS		BOLTS		NUTS	
Y	C35	1.0501	C35		C35
YK	CK35	1.1181	CK35		C35
G	24CrMo5	1.7258	24CrMo5		CK35
GA	21CrMoV57	1.7709	21CrMoV57		24CrMo5
	A2-70		A2-70		A2-70
	A4-70		A4-70		A4-70

All data, subject to technicals changes, are only for information and not for official use.

VALVOSIDER s.r.l. - Via S. Rocco, 2 - P.O. BOX 76 - 13011 Borgosesia (VC) - Italy
Phone: +39016322991 - Fax: +39016321537 - www.valvosider.com - e-mail: valvo@valvosider.com

RATING FOR GROUP 3E0 MATERIALS - GP240GH - 1.0619

TEMP. °C	GAUGE WORKING PRESSURE IN BAR				
	PN 16	PN 25	PN 40	PN 63	PN 100
RT	16,0	25,0	40,0	63,0	100,0
100	14,8	23,2	37,1	58,5	92,8
150	14,0	22,0	35,2	55,5	88,0
200	13,3	20,8	33,3	52,5	83,3
250	12,1	19,0	30,4	48,0	76,1
300	11,0	17,2	27,6	43,5	69,0
350	10,2	16,0	25,7	40,5	64,2
400	9,5	14,8	23,8	37,5	59,5
450					
460					
470					
480					
490					
500					

RATING FOR GROUP 4E0 MATERIALS - G20Mo5 - 1.5419

TEMP. °C	GAUGE WORKING PRESSURE IN BAR				
	PN 16	PN 25	PN 40	PN 63	PN 100
RT	16,0	25,0	40,0	63,0	100,0
100	16,0	25,0	40,0	63,0	100,0
150	16,0	25,0	40,0	63,0	100,0
200	16,0	25,0	40,0	63,0	100,0
250	15,6	24,4	39,0	61,5	97,6
300	13,7	21,4	34,2	54,0	85,7
350	12,9	20,2	32,3	51,0	80,9
400	11,9	18,6	29,9	47,1	74,7
450	11,0	17,2	27,6	43,5	69,0
460	10,2	16,0	25,6	40,3	64,0
470	9,4	14,7	23,6	37,2	59,1
480	8,6	13,5	21,6	34,1	54,2
490	7,8	12,3	19,7	31,0	49,2
500					

RATING FOR GROUP 5E0 MATERIALS - G17CrMo5-5 - 1.7357

TEMP. °C	GAUGE WORKING PRESSURE IN BAR				
	PN 16	PN 25	PN 40	PN 63	PN 100
RT	16,0	25,0	40,0	63,0	100,0
100	16,0	25,0	40,0	63,0	100,0
150	16,0	25,0	40,0	63,0	100,0
200	16,0	25,0	40,0	63,0	100,0
250	16,0	25,0	40,0	63,0	100,0
300	16,0	25,0	40,0	63,0	100,0
350	15,2	23,8	38,0	60,0	95,2
400	14,4	22,5	36,0	56,7	90,0
450	13,4	21,0	33,7	53,1	84,2
460	12,8	20,0	32,0	50,5	80,2
470	12,1	19,0	30,4	47,9	76,1
480	11,5	18,0	28,8	45,4	72,0
490	10,8	17,0	27,2	42,8	68,0
500					

RATING FOR GROUP 6E1 MATERIALS - GX15CrMo5 - 1.7365

TEMP. °C	GAUGE WORKING PRESSURE IN BAR				
	PN 16	PN 25	PN 40	PN 63	PN 100
RT	16,0	25,0	40,0	63,0	100,0
100	16,0	25,0	40,0	63,0	100,0
150	16,0	25,0	40,0	63,0	100,0
200	16,0	25,0	40,0	63,0	100,0
250	16,0	25,0	40,0	63,0	100,0
300	16,0	25,0	40,0	63,0	100,0
350	16,0	25,0	40,0	63,0	100,0
400	16,0	25,0	40,0	63,0	100,0
450	16,0	25,0	40,0	63,0	100,0
460					
470					
480					
490					
500					

RATING FOR GROUP 12E0 MATERIALS - GX5CrNiNb 19-11 - 1.4552

TEMP. °C	GAUGE WORKING PRESSURE IN BAR				
	PN 16	PN 25	PN 40	PN 63	PN 100
RT	16,0	25,0	40,0	63,0	100,0
100	15,8	24,7	39,6	62,4	99,0
150	14,9	23,3	37,3	58,8	93,3
200	14,1	22,1	35,4	55,8	88,5
250	13,4	21,0	33,7	53,1	84,2
300	12,7	19,8	31,8	50,1	79,5
350	12,2	19,1	30,6	48,3	76,6
400	11,8	18,5	29,7	46,8	74,2
450	11,6	18,1	29,0	45,7	72,6
500	11,3	17,7	28,3	44,7	70,9
550					
560					

RATING FOR GROUP 15E0 MATERIALS - GX5CrNiMoNb 19-11-2 - 1.4581

TEMP. °C	GAUGE WORKING PRESSURE IN BAR				
	PN 16	PN 25	PN 40	PN 63	PN 100
RT	16,0	25,0	40,0	63,0	100,0
100	16,0	25,0	40,0	63,0	100,0
150	15,6	24,5	39,2	61,8	98,0
200	14,9	23,3	37,3	58,8	93,3
250	14,1	22,1	35,4	55,8	88,5
300	13,3	20,8	33,3	52,5	83,3
350	12,8	20,1	32,1	50,7	80,4
400	12,4	19,5	31,2	49,2	78,0
450	12,2	19,1	30,6	48,3	76,6
500	12,0	18,8	30,0	47,4	75,2
550	11,9	18,6	29,9	47,1	74,7
560	11,8	18,5	29,6	46,6	74,0

All data, subject to technical changes, are only for information and not for official use.

FLOW COEFFICIENT, K_v

may be defined as the rate of flow of water in cubic metres per hour, that will generate a pressure drop of one bar across the valve.

FLOW COEFFICIENT, C_v

may be defined as the rate of flow of water in US gallons per minute, at 60 °F (15,6 °C), that will generate a pressure drop of one pound-force per square inch across the valve.

BASIC FORMULAS

Liquid flow:

$$K_v = \frac{Q\sqrt{G}}{\sqrt{(\Delta P)}} \quad ; \quad \Delta P = G \left(\frac{Q}{K_v} \right)^2$$

where
 Q = flow rate in cubic metres per hour;
 G = specific gravity of liquid (water = 1);
 ΔP = pressure drop across valve in bar.

$$C_v = \frac{Q\sqrt{G}}{\sqrt{(\Delta P)}} \quad ; \quad \Delta P = G \left(\frac{Q}{C_v} \right)^2$$

where
 Q = flow rate in US gal/min;
 G = specific gravity of liquid (water = 1);
 ΔP = pressure drop across valve in lbf/in²

Gases flow :

$$\Delta P = P_1 - \sqrt{P_1^2 - 2S_G T \left(\frac{W_G}{1360 \frac{K_v}{0.86}} \right)}$$

where
 P_1 = inlet pressure (PSIA);
 S_G = specific gravity of gas at standard conditions (air = 1);
 T = absolute temperature of gas (-460 °F)
 W_G = Volumetric flow of gas

Steam flow:

$$\Delta P = P_1 - \sqrt{P_1^2 - \left(\frac{1 + 0.0007 T_s}{2.1 \frac{K_v}{0.86}} \right) \cdot W^2}$$

where
 W = pound per hour of Steam;
 T_s = degree of superheat (°F);
 P_1 = inlet pressure
 ΔP = pressure drop across valve in lbf/in²

Each type and size of valve has a particular flow coefficient and the general formulas indicate how a knowledge of this can be used to establish the pressure drop across a valve for a given flow rate or, alternatively, to determinate the flow rate through a valve which will generate a given pressure drop.

Flow coefficient values are determined by testing and may not be valid for all conditions of flow.

CAST STEEL VALVES - FLOW COEFFICIENT K_v (m³/h) (C_v (US gal/minute) = $K_v/0.86$)

Type	Class	Nominal dimension											
		2"	3"	4"	6"	8"	10"	12"	14"	16"	18"	20"	24"
GATE VALVES	150	204	510	893	2074	3808	6035	8840	12325	16320	20825	23290	37060
	300	204	510	893	2074	3808	6035	8840	11339	15014	19159	21427	34095
	600	204	510	893	2074	3808	6035	10880	13065	17145	22330	27319	39704
	900	188	469	821	1908	3504	5552	10010	12019	15773	20543	25134	36527
	1500	173	432	756	1755	3223	5108	9209	11058	14511	18900	23123	33605
GLOBE VALVES	150	38	102	174	400	740	1190	1700	2380	3188	4080	5015	7225
	300	38	102	174	400	740	1190	1700	2380	3188	3754	4614	6647
	600	35	86	149	352	633	985	1415	2190	2268	--	--	--
	900	32	79	137	324	582	906	1302	2015	2087	--	--	--
	1500	30	73	126	298	536	834	1198	1853	1920	--	--	--
SWING CHECK VALVES F.B.	150	80	204	349	799	1479	2380	3400	4760	6375	8160	9350	14875
	300	77	198	338	775	1435	2309	3298	4617	6184	7915	9070	14429
	600	73	188	321	736	1363	2193	3133	4386	5874	7519	8616	13707
	900	70	179	305	700	1295	2083	2977	4167	5580	7143	8186	--
	1500	66	170	290	665	1231	1979	2828	3958	5301	6786	7777	--
STRAINERS	150	63	162	275	632	1170	1880	2687	3760	5036	6447	7388	--
	300	56	127	200	494	675	944	1378	1916	2874	4311	6467	9700
	600	56	127	200	494	675	944	1378	1916	2874	4311	6467	9700
	900	49	111	176	434	594	830	1213	1686	2529	3794	5691	8536
	1500	48	109	172	426	582	814	1188	1652	2479	3718	5577	8365
STRAINERS	1500	47	107	169	417	570	797	1165	1619	2429	3643	5466	8198
	2500	46	105	165	409	559	781	1141	1587	2380	3571	5356	8034

All data, subject to technical changes, are only for information and not for official use.

	Multiply →	by	→ to obtain		Multiply →	by	→ to obtain
Length	mil	25,4	μ (micron)	Velocity	ft/s (foot per second)	3,281	m/s (metre per second)
	in (inch)	25,4	mm		m/min (metre per minute)	60	m/s (metre per second)
	ft (foot)	0,3048	m		ft/min (foot per minute)	196,85	m/s (metre per second)
	yd (yard)	0,9144	m		mile/h (mile per hour)	1,6093	km/h (kilometre per hour)
	miles (nautical)	1,853	km		m/s (metre per second)	3,6	km/h (kilometre per hour)
	miles (statute)	1,609	km				
Area	sq.in. (square inch)	6,4516	cm ²	Dynamic viscosity	g/ (cm s) (Poise)	0,1	Pa s = kg / (m s)
	sq.ft. (square foot)	0,0929	cm ²		centipoise	0,001	Pa s
	sq.yd. (square yard)	0,8361	cm ²		lb/ (ft s)	1,48819	Pa s
Volume	cu.in (cubic inch)	16,387	cm ³	Kinematic viscosity	cm ² (Stokes)	0,0001	m ² /s
	cu.ft. (cubic foot)	28,317	dm ³		centistokes	0,000001	m ² /s
	UK gal (UK gallon)	4,5461	dm ³		ft ² / s	0,09290	m ² /s
	US gal (US gallon)	3,7854	dm ³	Moment of force	N m (newton metre)	0,001	kN m (kilonewton metre)
	bushel	35,24	dm ³		kN m	101,972	kgf m (kilogram-force metre)
	US gal (US gallon)	42	Us barrel		kgf m	86,8	lbf in (Pound-force inch)
	UK pint	1,76	l (litre)		lbf ft (Pound-force foot)	12	lbf in (Pound-force inch)
	l (litre)	1000	cm ³	lbf ft (Pound-force foot)	1,356	N m (newton metre)	
	l (litre)	1	dm ³				
	m3 (cubic metre)	1000	l (litre)				
Mass	grains	0,0648	g	Mass per unit length	kg/m	0,672	lb/ft
	lb (pound)	0,4536	kg		lb/ft	1,488	kg/m
	oz (ounce)	28,3495	g	Mass per unit area	kg/m ²	0,2048	lb/ft ²
	ton (UK ton)	1016,05	kg		lb/ft ²	4,882	kg/m ²
	sh ton (US ton)	907,2	kg	Thermal conductivity	W/(m °C)	6,934	Btu in/(ft ² h °F)
	t (tonne)	1000	kg		Btu in/ft ² °F	0,1442	W/(m °C)
Pressure and Stress	kgf/cm ² = ate	0,980556	bar	Entalpy	Btu (British Thermal Unit)	1055	J (Joule)
	Pa (Pascal) = N/m ²	0,00001	bar		Btu	0,252	kcal = Cal
	MPa (Megapascal)	10	bar		J	0,73560	ft lb
	mm H ₂ O	9,80665	Pa		kWh	3600	kJ
	Torr (mm Hg)	133,322	Pa	Power	Btu	0,252	kcal = Cal
	psi (lbs per square inch)	0,068941	bar		kcal	4186,8	J
UK tonf/in ²	15,44	Mpa	Energy	kJ/kg	0,239	kcal/kg	
				kW	1,34102	hp	
				hp	746	watt	
Density	lb/in ³	27,680	g/cm ³	Calorific value (volume basis)	MJ/m ³	26,84	Btu/ft ³
	lb/ft ³	0,01602	g/cm ³		Btu/ft ³	0,03726	MJ/m ³
	g/cm ³	1000	litre - g/dm ³		Btu/ft ³	37,26	kJ7m ³
	kg/m ³	0,752	ton/yd ³	Force	N (Newton)	0,102	kgf = kp (unità in disuso)
ton/yd ³	13,319	lb/Ukgal	lbf (pound-force)		4,4483	N	
				kgf = kp	2,205	lbf	
	to obtain ←	by	← Divide		to obtain ←	by	← Divide
To →			add	→ to obtain			
psig (psi at gauge)			14,70	psia (psi absolute)			
bar (at gauge)			1,01325	bar absolute			
°C (degrees Celsius)			273,15	K (degees Kelvin)			
°F (degrees Fahrenheit)			459,4	°R (degrees Rankine)			
to obtain ←			subtract	← To			

All data, subject to technical changes, are only for information and not for official use.

TEMPERATURE CONVERSION

FAHRENHEIT AND CENTIGRADE

VALVOSIDER
MANUFACTURER OF VALVES

°C	(a)		°C	(a)		°C	(a)		°C	(a)		°C	(a)	
	°C → °F	°F ← °C		°C → °F	°F ← °C		°C → °F	°F ← °C		°C → °F	°F ← °C		°C → °F	°F ← °C
			-17,2	1	33,8	16,1	61	141,8	149	300	572	482	900	1652
			-16,7	2	35,6	16,7	62	143,6	154	310	590	488	910	1670
			-16,1	3	37,4	17,2	63	145,4	160	320	608	493	920	1688
			-15,6	4	39,2	17,8	64	147,2	166	330	626	499	930	1706
			-15,0	5	41,0	18,3	65	149,0	171	340	644	504	940	1724
			-14,4	6	42,8	18,9	66	150,8	177	350	662	510	950	1742
			-13,9	7	44,6	19,4	67	152,6	182	360	680	516	960	1760
			-13,3	8	46,4	20,0	68	154,4	188	370	698	521	970	1778
			-12,8	9	48,2	20,6	69	156,2	193	380	716	527	980	1796
			-12,2	10	50,0	21,1	70	158,0	199	390	734	532	990	1814
			-11,7	11	51,8	21,7	71	159,8	204	400	752	538	1000	1832
-273	-459,4		-11,1	12	53,6	22,2	72	161,6	210	410	770	549	1020	1868
-268	-450		-10,6	13	55,4	22,8	73	163,4	216	420	788	560	1040	1904
-262	-440		-10,0	14	57,2	23,3	74	165,2	221	430	806	571	1060	1940
-257	-430		-9,4	15	59,0	23,9	75	167,0	227	440	824	582	1080	1976
-251	-420		-8,9	16	60,8	24,4	76	168,8	232	450	842	593	1100	2012
-246	-410		-8,3	17	62,6	25,0	77	170,6	238	460	860	604	1120	2048
-240	-400		-7,8	18	64,4	25,6	78	172,4	243	470	878	616	1140	2084
-234	-390		-7,2	19	66,2	26,1	79	174,2	249	480	896	627	1160	2120
-229	-380		-6,7	20	68,0	26,7	80	176,0	254	490	914	638	1180	2156
-223	-370		-6,1	21	69,8	27,2	81	177,8	260	500	932	649	1200	2192
-218	-360		-5,6	22	71,6	27,8	82	179,6	266	510	950	660	1220	2228
-212	-350		-5,0	23	73,4	28,3	83	181,4	271	520	968	671	1240	2264
-207	-340		-4,4	24	75,2	28,9	84	183,2	277	530	986	682	1260	2300
-201	-330		-3,9	25	77,0	29,4	85	185,0	282	540	1004	693	1280	2336
-196	-320		-3,3	26	78,8	30,0	86	186,8	288	550	1022	704	1300	2372
-190	-310		-2,8	27	80,6	30,6	87	188,6	293	560	1040	732	1350	2462
-184	-300		-2,2	28	82,4	31,1	88	190,4	299	570	1058	760	1400	2552
-179	-290		-1,7	29	84,2	31,7	89	192,2	304	580	1076	788	1450	2642
-173	-280		-1,1	30	86,0	32,2	90	194,0	310	590	1094	816	1500	2732
-169	-273	-459,4	-0,6	31	87,8	32,8	91	195,8	316	600	1112	843	1550	2822
-168	-270	-454	0,0	32	89,6	33,3	92	197,6	321	610	1130	871	1600	2912
-162	-260	-436	0,6	33	91,4	33,9	93	199,4	327	620	1148	899	1650	3002
-157	-250	-418	1,1	34	93,2	34,4	94	201,2	332	630	1166	927	1700	3092
-151	-240	-400	1,7	35	95,0	35,0	95	203,0	338	640	1184	954	1750	3182
-146	-230	-382	2,2	36	96,8	35,6	96	204,8	343	650	1202	982	1800	3272
-140	-220	-364	2,8	37	98,6	36,1	97	206,6	349	660	1220	1010	1850	3362
-134	-210	-346	3,3	38	100,4	36,7	98	208,4	354	670	1238	1038	1900	3452
-129	-200	-328	3,9	39	102,2	37,2	99	210,2	360	680	1256	1066	1950	3542
-123	-190	-310	4,4	40	104,0	37,8	100	212,0	366	690	1274	1093	2000	3632
-118	-180	-292	5,0	41	105,8	43	110	230	371	700	1292	1121	2050	3722
-112	-170	-274	5,6	42	107,6	49	120	248	377	710	1310	1149	2100	3812
-107	-160	-256	6,1	43	109,4	54	130	266	382	720	1328	1177	2150	3902
-101	-150	-238	6,7	44	111,2	60	140	284	388	730	1346	1204	2200	3992
-96	-140	-220	7,2	45	113,0	66	150	302	393	740	1364	1232	2250	4082
-90	-130	-202	7,8	46	114,8	71	160	320	399	750	1382	1260	2300	4172
-84	-120	-184	8,3	47	116,6	77	170	338	404	760	1400	1288	2350	4262
-79	-110	-166	8,9	48	118,4	82	180	356	410	770	1418	1316	2400	4352
-73	-100	-148	9,4	49	120,2	88	190	374	416	780	1436	1343	2450	4442
-68	-90	-130	10,0	50	122,0	93	200	392	421	790	1454	1371	2500	4532
-62	-80	-112	10,6	51	123,8	99	210	410	427	800	1472	1399	2550	4622
-57	-70	-94	11,1	52	125,6	100	212	414	432	810	1490	1427	2600	4712
-51	-60	-76	11,7	53	127,4	104	220	428	438	820	1508	1454	2650	4802
-46	-50	-58	12,2	54	129,2	110	230	446	443	830	1526	1482	2700	4892
-40	-40	-40	12,8	55	131,0	116	240	464	449	840	1544	1510	2750	4982
-34	-30	-22	13,3	56	132,8	121	250	482	454	850	1562	1538	2800	5072
-29	-20	-4	13,9	57	134,6	127	260	500	460	860	1580	1566	2850	5162
-28	-18	0	14,4	58	136,4	132	270	518	466	870	1598	1593	2900	5252
-23	-10	14	15,0	59	138,2	138	280	536	471	880	1616	1621	2950	5342
-18	0	32	15,6	60	140,0	143	290	554	477	890	1634	1649	3000	5432

The central column (a) represent the know temperature in °C or in °F.
 The equivalent temperature in °F or in °C is then read from the column to the right or the left.
 General Formula $^{\circ}\text{C} = (^{\circ}\text{F} - 32) \times 5/9$
 $^{\circ}\text{F} = (^{\circ}\text{C} \times 9/5) + 32$

All data, subject to technicals changes, are only for information and not for official use.

VALVOSIDER s.r.l. - Via S. Rocco, 2 - P.O. BOX 76 - 13011 Borgosesia (VC) - Italy
 Phone: +39016322991 - Fax: +39016321537 - www.valvosider.com - e-mail: valvo@valvosider.com

INCHES	0	1/16	1/8	3/16	1/4	5/16	3/8	7/16	1/2	9/16	5/8	11/16	3/4	13/16	7/8	15/16
0	0,00	1,59	3,18	4,76	6,35	7,94	9,53	11,11	12,70	14,29	15,88	17,46	19,05	20,64	22,23	23,81
1	25,40	26,99	28,58	30,16	31,75	33,34	34,93	36,51	38,10	39,69	41,28	42,86	44,45	46,04	47,63	49,21
2	50,80	52,39	53,98	55,56	57,15	58,74	60,33	61,91	63,50	65,09	66,68	68,26	69,85	71,44	73,03	74,61
3	76,20	77,79	79,38	80,96	82,55	84,14	85,73	87,31	88,90	90,49	92,08	93,66	95,25	96,84	98,43	100,01
4	101,60	103,19	104,78	106,36	107,95	109,54	111,13	112,71	114,30	115,89	117,48	119,06	120,65	122,24	123,83	125,41
5	127,00	128,59	130,18	131,76	133,35	134,94	136,53	138,11	139,70	141,29	142,88	144,46	146,05	147,64	149,23	150,81
6	152,40	153,99	155,58	157,16	158,75	160,34	161,93	163,51	165,10	166,69	168,28	169,86	171,45	173,04	174,63	176,21
7	177,80	179,39	180,98	182,56	184,15	185,74	187,33	188,91	190,50	192,09	193,68	195,26	196,85	198,44	200,03	201,61
8	203,20	204,79	206,38	207,96	209,55	211,14	212,73	214,31	215,90	217,49	219,08	220,66	222,25	223,84	225,43	227,01
9	228,60	230,19	231,78	233,36	234,95	236,54	238,13	239,71	241,30	242,89	244,48	246,06	247,65	249,24	250,83	252,41
10	254,00	255,59	257,18	258,76	260,35	261,94	263,53	265,11	266,70	268,29	269,88	271,46	273,05	274,64	276,23	277,81
11	279,40	280,99	282,58	284,16	285,75	287,34	288,93	290,51	292,10	293,69	295,28	296,86	298,45	300,04	301,63	303,21
12	304,80	306,39	307,98	309,56	311,15	312,74	314,33	315,91	317,50	319,09	320,68	322,26	323,85	325,44	327,03	328,61
13	330,20	331,79	333,38	334,96	336,55	338,14	339,73	341,31	342,90	344,49	346,08	347,66	349,25	350,84	352,43	354,01
14	355,60	357,19	358,78	360,36	361,95	363,54	365,13	366,71	368,30	369,89	371,48	373,06	374,65	376,24	377,83	379,41
15	381,00	382,59	384,18	385,76	387,35	388,94	390,53	392,11	393,70	395,29	396,88	398,46	400,05	401,64	403,23	404,81
16	406,40	407,99	409,58	411,16	412,75	414,34	415,93	417,51	419,10	420,69	422,28	423,86	425,45	427,04	428,63	430,21
17	431,80	433,39	434,98	436,56	438,15	439,74	441,33	442,91	444,50	446,09	447,68	449,26	450,85	452,44	454,03	455,61
18	457,20	458,79	460,38	461,96	463,55	465,14	466,73	468,31	469,90	471,49	473,08	474,66	476,25	477,84	479,43	481,01
19	482,60	484,19	485,78	487,36	488,95	490,54	492,13	493,71	495,30	496,89	498,48	500,06	501,65	503,24	504,83	506,41
20	508,00	509,59	511,18	512,76	514,35	515,94	517,53	519,11	520,70	522,29	523,88	525,46	527,05	528,64	530,23	531,81
21	533,40	534,99	536,58	538,16	539,75	541,34	542,93	544,51	546,10	547,69	549,28	550,86	552,45	554,04	555,63	557,21
22	558,80	560,39	561,98	563,56	565,15	566,74	568,33	569,91	571,50	573,09	574,68	576,26	577,85	579,44	581,03	582,61
23	584,20	585,79	587,38	588,96	590,55	592,14	593,73	595,31	596,90	598,49	600,08	601,66	603,25	604,84	606,43	608,01
24	609,60	611,19	612,78	614,36	615,95	617,54	619,13	620,71	622,30	623,89	625,48	627,06	628,65	630,24	631,83	633,41
25	635,00	636,59	638,18	639,76	641,35	642,94	644,53	646,11	647,70	649,29	650,88	652,46	654,05	655,64	657,23	658,81
26	660,40	661,99	663,58	665,16	666,75	668,34	669,93	671,51	673,10	674,69	676,28	677,86	679,45	681,04	682,63	684,21
27	685,80	687,39	688,98	690,56	692,15	693,74	695,33	696,91	698,50	700,09	701,68	703,26	704,85	706,44	708,03	709,61
28	711,20	712,79	714,38	715,96	717,55	719,14	720,73	722,31	723,90	725,49	727,08	728,66	730,25	731,84	733,43	735,01
29	736,60	738,19	739,78	741,36	742,95	744,54	746,13	747,71	749,30	750,89	752,48	754,06	755,65	757,24	758,83	760,41
30	762,00	763,59	765,18	766,76	768,35	769,94	771,53	773,11	774,70	776,29	777,88	779,46	781,05	782,64	784,23	785,81
31	787,40	788,99	790,58	792,16	793,75	795,34	796,93	798,51	800,10	801,69	803,28	804,86	806,45	808,04	809,63	811,21
32	812,80	814,39	815,98	817,56	819,15	820,74	822,33	823,91	825,50	827,09	828,68	830,26	831,85	833,44	835,03	836,61
33	838,20	839,79	841,38	842,96	844,55	846,14	847,73	849,31	850,90	852,49	854,08	855,66	857,25	858,84	860,43	862,01
34	863,60	865,19	866,78	868,36	869,95	871,54	873,13	874,71	876,30	877,89	879,48	881,06	882,65	884,24	885,83	887,41
35	889,00	890,59	892,18	893,76	895,35	896,94	898,53	900,11	901,70	903,29	904,88	906,46	908,05	909,64	911,23	912,81
36	914,40	915,99	917,58	919,16	920,75	922,34	923,93	925,51	927,10	928,69	930,28	931,86	933,45	935,04	936,63	938,21
37	939,80	941,39	942,98	944,56	946,15	947,74	949,33	950,91	952,50	954,09	955,68	957,26	958,85	960,44	962,03	963,61
38	965,20	966,79	968,38	969,96	971,55	973,14	974,73	976,31	977,90	979,49	981,08	982,66	984,25	985,84	987,43	989,01
39	990,60	992,19	993,78	995,36	996,95	998,54	1000,13	1001,71	1003,30	1004,89	1006,48	1008,06	1009,65	1011,24	1012,83	1014,41
40	1016,00	1017,59	1019,18	1020,76	1022,35	1023,94	1025,53	1027,11	1028,70	1030,29	1031,88	1033,46	1035,05	1036,64	1038,23	1039,81
41	1041,40	1042,99	1044,58	1046,16	1047,75	1049,34	1050,93	1052,51	1054,10	1055,69	1057,28	1058,86	1060,45	1062,04	1063,63	1065,21
42	1066,80	1068,39	1069,98	1071,56	1073,15	1074,74	1076,33	1077,91	1079,50	1081,09	1082,68	1084,26	1085,85	1087,44	1089,03	1090,61
43	1092,20	1093,79	1095,38	1096,96	1098,55	1100,14	1101,73	1103,31	1104,90	1106,49	1108,08	1109,66	1111,25	1112,84	1114,43	1116,01
44	1117,60	1119,19	1120,78	1122,36	1123,95	1125,54	1127,13	1128,71	1130,30	1131,89	1133,48	1135,06	1136,65	1138,24	1139,83	1141,41
45	1143,00	1144,59	1146,18	1147,76	1149,35	1150,94	1152,53	1154,11	1155,70	1157,29	1158,88	1160,46	1162,05	1163,64	1165,23	1166,81
46	1168,40	1169,99	1171,58	1173,16	1174,75	1176,34	1177,93	1179,51	1181,10	1182,69	1184,28	1185,86	1187,45	1189,04	1190,63	1192,21
47	1193,80	1195,39	1196,98	1198,56	1200,15	1201,74	1203,33	1204,91	1206,50	1208,09	1209,68	1211,26	1212,85	1214,44	1216,03	1217,61
48	1219,20	1220,79	1222,38	1223,96	1225,55	1227,14	1228,73	1230,31	1231,90	1233,49	1235,08	1236,66	1238,25	1239,84	1241,43	1243,01
49	1244,60	1246,19	1247,78	1249,36	1250,95	1252,54	1254,13	1255,71	1257,30	1258,89	1260,48	1262,06	1263,65	1265,24	1266,83	1268,41
50	1270,00	1271,59	1273,18	1274,76	1276,35	1277,94	1279,53	1281,11	1282,70	1284,29	1285,88	1287,46	1289,05	1290,64	1292,23	1293,81

All data, subject to technical changes, are only for information and not for official use.



TERMS AND CONDITIONS

Quotes are made without any obligation. An order is considered accepted when our order acknowledgement is received.

Orders are non-cancellable unless approved by management and cancellation charges may apply.

Prices are quoted "ex works" Borgosesia. All transportation charges, insurance, customs charges, special packing, any other fees will be the customer's (buyer's) responsibility, as well as any delays on delivery of goods.

Valvosider will not be responsible for any interruption or setback on delivery or delays in completing the contract due to strikes, work stoppages, fires, floods, accidents, inability to obtain materials, fuel, transportation or any other causes beyond our control. Penalty will not apply if not written in the contract.

All complaints and claims about shortages, corrections and/or reductions should be made within 30 days after receipt of goods. Damages and/or loss of goods in transit will be the sole responsibility of the carrier and all claims should be filed directly with them.

All amount of invoice due to Valvosider must be paid without rebate, deductions or set-off of any kind. The customer (buyer) should never have the right to suspend his obligation.

The customer (buyer) will have an interest bearing debt equal to the statutory rate of interest in Italy at the time of all or any unpaid portion on the last day of the payment term.

Valvosider reserves the right to change or modify the design and construction of any product without incurring any obligation to supply, substitute or modify goods previously sold.

Before shipment all goods are carefully tested. Valvosider guarantees its products against any defective material and workmanship for a period of up to one year from shipping date as long as goods are used for its intended and recommended purpose. Valvosider's obligation under warranty is limited to repair of the product or replacement of any part or parts having defects in material or workmanship. The customer (buyer) shall permit Valvosider to inspect the product to determine if indeed is warranty work.

Valvosider is not responsible to damages done to the product during repairs and/or replacement, said obligations and remedies to be sole warranty given hereunder. No warranty will apply to any product which has been modified, altered or changed in design or function after leaving the Valvosider factory.

Catalog pictures are only shown as a reference of the different products made by Valvosider. The actual product may vary in its design as changes are made for improvement to the product.

In case of controversy only the judicial authorities of Vercelli, Italy law court are competent.

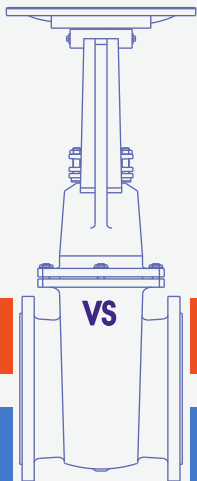

ASME

DIN

VALVOSIDER s.r.l.

Via S. Rocco, 2 - P.O. BOX 76 - 13011 Borgosesia (VC) - Italy

Phone: +39 0163 22991 - Fax: +39 0163 21537

e-mail: valvo@valvosider.com - <http://www.valvosider.com>