



BONETTI

FLOATING BALL VALVES

PN40

DN 15 - 65 Flanged according to UNI / DIN

SFA

SFS

Features

The floating ball valve **SFA** has Carbon steel body and alloy steel trim suitable for high temperature. Thanks to a new patented innovative seat and to Carbon reinforced PTFE sealings, the valve is suitable for hot media under pressure, as steam or superheated water.

Besides, this ball valve is designed to avoid leakages and fugitive emissions in the environment as well as to maintain a safe tightness also in case of fire, so being suitable for dangerous or flammable media too.

The innovative feature of this valve is the "double sealing system", that is the capability to grant sealing both by downstream seating, as in usual floating ball valves, and also by upstream seating (see Fig. 1).

SFS ball valve has identical features, but it is manufactured with body and trim in austenitic stainless steel. Therefore it is the ideal solution for corrosive media or corrosive atmosphere. Those valves are bi-directional and could be fitted with electric or pneumatic actuator.

Valves are suitable with full or reduced bore

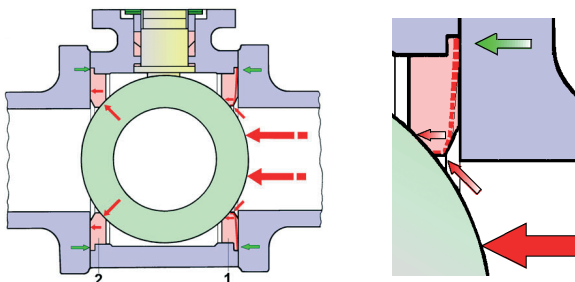

Fig. 1

Reference Standards

PED Directive (97/23/CE)
EN 1092-1 for flange dimension
EN 558-1 (DIN 3202 F1) for end to end dimension
ISO 15848-1 ("fugitive emission")
API607 ("fire safe")

Working condition

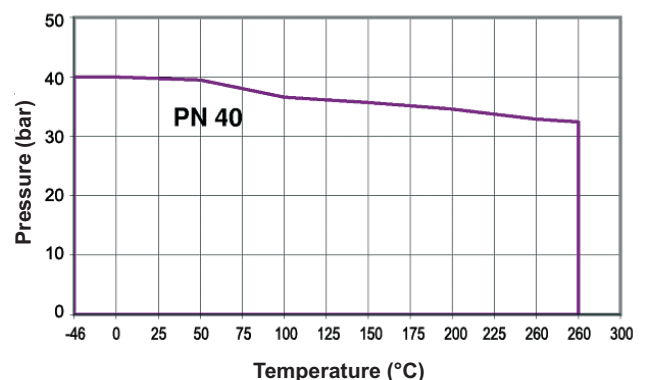

Fig. 2

Fig. 2 shows operating range of valves
Note: for temperatures under -46 °C, please apply to our Technical or Sales Department.

Technical data

Bore:	Reduced or full
On line tightness:	Grade A according to ISO 5208
Antistatic device:	According to ISO7121 and BS5351
Connections:	Flanged according to PN16 - PN40, End to end according to EN 558-1 (DIN 3202 F1- see Fig 4)

Operating starting torque (Nm) at 40 Bar

DN	15	20	25	32	40	50	65
Reduced bore	-	7	15	21	30	40	45
Full bore	7	15	21	30	40	45	-

Above values refer to a frequently operated valve.
In case the valve is not operated for a long time, or in case of heavy media, the operating starting torque must be increased.

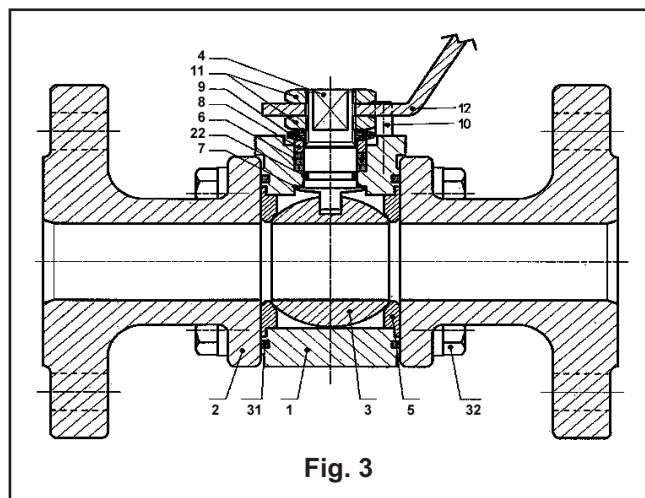

Fig. 3

Option

- Depressurizing hole on the ball.
- Extended stem.
- Oval hand-wheel for application in small spaces.

Safety informations for installation and maintenance

For detailed informations about installation, maintenance and safety criteria, please refer to Use and Maintenance Manual.

Spare parts

Suggested spares parts are evidenced by an asterisk on the Table of materials (Table 1).

Dimension and weight

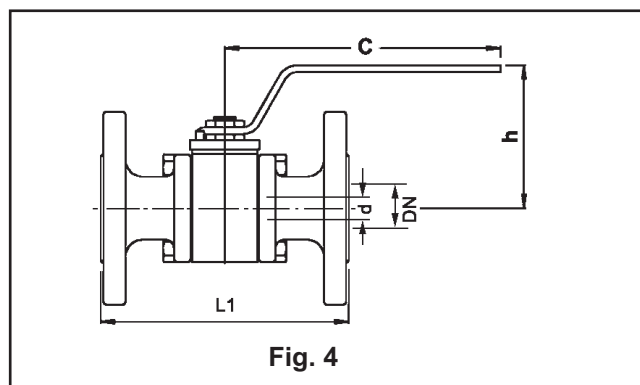

Fig. 4

Table 1

No.	Item	Execution SFA	Execution SFS
1	Body	A105 / A350 LF2	AISI 316
2	Cap	A105 / A350 LF2	AISI 316
3	Ball	1.4301/1.4086 (a)	AISI 316
4	Stem	1.4104 HT	AISI 316
5*	Seat ring	RPTFE (b)	RPTFE (b)
6*	Packing ring	Graphite	Graphite
7*	Antifriction washer	RPTFE (b)	RPTFE (b)
8	Packing gland	CS galvanized	AISI 316
9	Belleville washer	Ck 70	SS
10	Stop pin	CS galvanized	AISI 316
11	Nut	CS galvanized	AISI 316
12	Handle	CS galvanized and polimerized	CS galvanized and polimerized
22*	O-ring	FKM	FKM
31*	Body seal	Graphite	Graphite
32	Bolt	B7 galvanized	B8

(a) 1.4301(AISI 304) for DN ≤ 25
1.4086 (AISI 430F) for DN > 25

(b) RPTFE = PTFE + 25% carbon

Full bore valves

DN	L1 mm	C mm	h mm	d mm	Top mounting	Weight Kg	Kv
15	130	145	87	15	F03	2.8	10,5
20	150	170	98	20	F04	4.0	27.3
25	160	170	103	25	F04	5.3	40
32	180	212	107	32	F05	8.4	66,5
40	200	212	113	40	F05	10.5	98
50	230	303	142	50	F07	15.8	225

reduced bore valves

	L1 mm	C mm	h mm	DN mm	d mm	Top mounting	Weight Kg	Kv
20x15	150	145	87	20	15	F03	3.5	11,5
25x20	160	170	98	25	20	F04	4.4	29
32x25	180	170	103	32	25	F04	6.9	43
40x32	200	212	107	40	32	F05	8.9	70
50x40	230	212	113	50	40	F05	12.1	102
65x50	290	303	142	65	50	F07	18.9	240

CESARE BONETTI S.p.A.

Via Cesare Bonetti 17 - 20024 Garbagnate Milanese (Italy)
 Telefono: +3902 990721
 Telefax: +3902 9952483
 Internet web site: <http://www.cesare-bonetti.it>
 E-mail: bont.post@bont.it

Vendite Italia: Telefono: +39 02 99 072 333
 Telefax: +39 02 99 072 300
 E-mail: italia@bont.it
 Export sales: Telephone: +39 02 99 072 444
 Telefax: +39 02 99 072 400
 E-mail: export@bont.it