



# Bringing Energy Down to Earth

---

## Say energy. Think environment. And vice versa.

Any company that is energy conscious is also environmentally conscious. Less energy consumed means less waste, fewer emissions and a healthier environment.

In short, bringing energy and environment together lowers the cost industry must pay for both. By helping companies manage energy, Armstrong products and services are also helping to protect the environment.

Armstrong has been sharing know-how since we invented the energy-efficient inverted bucket steam trap in 1911. In the years since, customers' savings have proven again and again that **knowledge *not* shared is energy wasted.**

Armstrong's developments and improvements in steam trap design and function have led to countless savings in energy, time and money. This section has grown out of our decades of sharing and expanding what we've learned. It deals with the operating principles of steam traps and outlines their specific applications to a wide variety of products and industries. You'll find it a useful complement to other Armstrong literature and tools, such as the "Armstrong Interactive" CD-ROM and the "Trap-A-Ware" sizing and selection software, which can be ordered on Armstrong's European web site [www.armstrong.be](http://www.armstrong.be).

This section also includes Recommendation Charts that summarize our findings on which type of trap will give optimum performance in a given situation and why.

**IMPORTANT:** This section is intended to summarize general principles of installation and operation of steam traps, as outlined above. Actual installation and operation of steam trapping equipment should be performed only by experienced personnel. Selection or installation should always be accompanied by competent technical assistance or advice. This data should never be used as a substitute for such technical advice or assistance. We encourage you to contact Armstrong or its local representative for further details.

# Instructions for Using the Recommendation Charts



A quick reference Recommendation Chart appears throughout the "HOW TO TRAP" sections of this Handbook, pages CG-24 to CG-50.

A feature code system (ranging from A to Q) supplies you with "at-a-glance" information.

The chart covers the type of steam traps and the major advantages that Armstrong feels are superior for each particular application.

For example, assume you are looking for information concerning the proper trap to use on a gravity drained jacketed kettle. You would:

1. Turn to the "How to Trap Jacketed Kettles" section, pages CG-42 to CG-43, and look in the lower right-hand corner of page CG-42. The Recommendation Chart located there is reprinted below for your convenience. (Each section has a Recommendation Chart.)
2. Find "Jacketed Kettles, Gravity Drain" in the first column under "Equipment Being Trapped" and read to the right for Armstrong's "1st Choice and Feature Code." In this case, the first choice is an IBLV and the feature code letters B, C, E, K, N are listed.
3. Now refer to Chart CG-9-2 below, titled "How Various Types of Steam Traps Meet Specific Operating Requirements" and read down the extreme left-hand column to each of the letters B, C, E, K, N. The letter "B," for example, refers to the trap's ability to provide energy-conserving operation.

4. Follow the line for "B" to the right until you reach the column that corresponds to our first choice, in this case the inverted bucket. Based on tests and actual operating conditions, the energy-conserving performance of the inverted bucket steam trap has been rated "Excellent." Follow this same procedure for the remaining letters.

## Abbreviations

- IB Inverted Bucket Trap
- IBLV Inverted Bucket Large Vent
- F&T Float and Thermostatic Trap
- CD Controlled Disc or Thermodynamic Trap
- DC Automatic Differential Condensate Controller
- CV Check Valve
- T Thermic Bucket
- PRV Pressure Reducing Valve

**Table CG-9-1. Recommendation Chart**  
(See chart below for "Feature Code" References.)

Equipment Being Trapped	1st Choice and Feature Code	Alternate Choice
Jacketed Kettles Gravity Drain	IBLV B, C, E, K, N	F&T or Thermostatic
Jacketed Kettles Syphon Drain	DC B, C, E, G, H, K, N, P	IBLV

**Table CG-9-2. How Various types of Steam Traps Meet Specific Operating Requirements**

Feature Code	Characteristics	Inverted Bucket	F&T	Disc	Thermostatic	Differential Controller
A	Method of Operation	(1) Intermittent	Continuous	Intermittent	(2) Intermittent	Continuous
B	Energy Conservation (Time in Service)	Excellent	Good	Poor	Fair	(3) Excellent
C	Resistance to Wear	Excellent	Good	Poor	Fair	Excellent
D	Corrosion Resistance	Excellent	Good	Excellent	Good	Excellent
E	Resistance to Hydraulic shock	Excellent	Poor	Excellent	(4) Poor	Excellent
F	Vents Air and CO <sub>2</sub> at Steam Temperature	Yes	No	No	No	Yes
G	Ability to Vent Air at Very Low Pressure (0,02 barg)	Poor	Excellent	(5) NR	Good	Excellent
H	Ability to Handle Start-Up Air Loads	Fair	Excellent	Poor	Excellent	Excellent
I	Operation Against Back Pressure	Excellent	Excellent	Poor	Excellent	Excellent
J	Resistance to Damage From Freezing (6)	Good	Poor	Good	Good	Good
K	Ability to Purge System	Excellent	Fair	Excellent	Good	Excellent
L	Performance on Very Light Loads	Excellent	Excellent	Poor	Excellent	Excellent
M	Responsiveness to Slugs of Condensate	Immediate	Immediate	Delayed	Delayed	Immediate
N	Ability to Handle Dirt	Excellent	Poor	Poor	Fair	Excellent
O	Comparative Physical Size	(7) Large	Large	Small	Small	Large
P	Ability to Handle "Flash Steam"	Fair	Poor	Poor	Poor	Excellent
Q	Mechanical Failure (Open or Closed)	Open	Closed	(8) Open	(9)	Open

(1) Drainage of condensate is continuous. Discharge is intermittent.  
 (2) Can be continuous on low load.  
 (3) Excellent when "secondary steam" is utilized.  
 (4) Bimetallic and wafer traps – good.  
 (5) Not recommended for low pressure operations.

(6) Cast iron traps not recommended.  
 (7) In welded stainless steel construction – medium.  
 (8) Can fail closed due to dirt.  
 (9) Can fail either open or closed, depending upon the design of the bellows.



# Steam Tables

Steam Conservation Guidelines

## What They Are...How to Use Them

The heat quantities and temperature/pressure relationships referred to in this section are taken from the Properties of Saturated Steam table.

## Definitions of Terms Used

**Saturated Steam** is pure steam at the temperature that corresponds to the boiling temperature of water at the existing pressure.

### Absolute and Gauge Pressures

(Column 1). Absolute pressure is pressure in bar (bar(a)) above a perfect vacuum. Gauge pressure is pressure in bar (barg) above atmospheric pressure, which is 1 bar absolute. Gauge pressure (barg) plus 1 equals absolute pressure. Or, absolute pressure in bar minus 1 equals gauge pressure.

**Pressure/Temperature Relationship** (Columns 1 and 2). For every pressure of saturated steam there is a corresponding temperature. Example: The temperature of 9 barg saturated steam is always 179,9°C.

**Specific Volume of Steam** (Column 3). The volume per unit of mass in m<sup>3</sup>/kg.

**Heat of Saturated Liquid** (Column 4 and 6). This is the amount of heat required to raise the temperature of one kilogram of water from 0°C to the boiling point at the pressure and temperature shown. It is expressed in kilojoules (kJ) or kilocalories (kcal).

**Latent Heat or Heat of Vaporization** (Column 5 and 7). The amount of heat required to change a kilogram of boiling water to a kilogram of steam. This same amount of heat is released when a kilogram of steam is condensed back into a kilogram of water. This heat quantity is different for every pressure/temperature combination, as shown in the steam table.

## How the Table is Used

In addition to determining pressure/temperature relationships, you can compute the amount of steam that will be condensed by any heating unit of known kJ (kcal) output.

Conversely, the table can be used to determine kJ (kcal) output if steam condensing rate is known. In the application portion of this section, there are several references to the use of the steam table.

**Table CG-10-1. Properties of Saturated Steam**

Steam Pressure (bar abs.)	Steam Temp. (°C)	Spec. Volume (m <sup>3</sup> /kg)	Kilojoules		Kilocalories	
			Heat of Saturated Liquid (kJ/kg)	Latent Heat (kJ/kg)	Heat of Saturated Liquid (kcal/kg)	Latent Heat (kcal/kg)
Column 1	Column 2	Column 3	Column 4	Column 5	Column 6	Column 7
P	t	SV	q	r	q	r
0,01	7,0	129,20	29	2 484	7,0	593,5
0,02	17,5	67,01	73	2 460	17,5	587,6
0,03	24,1	45,67	101	2 444	24,1	583,9
0,04	29,0	34,80	121	2 433	28,9	581,2
0,05	32,9	28,19	138	2 423	32,9	578,9
0,06	36,2	23,47	151	2 415	36,2	577,0
0,07	39,0	20,53	163	2 409	39,0	575,5
0,08	41,5	18,10	174	2 403	41,5	574,0
0,09	43,8	16,20	183	2 398	43,7	572,8
0,10	45,8	14,67	192	2 393	45,8	571,8
0,20	60,1	7,650	251	2 358	60,1	563,3
0,30	69,1	5,229	289	2 335	69,1	558,0
0,40	75,9	3,993	317	2 319	75,8	554,0
0,50	81,3	3,240	340	2 305	81,3	550,7
0,60	86,0	2,732	359	2 293	85,9	547,9
0,70	90,0	2,365	376	2 283	89,9	545,5
0,80	93,5	2,087	391	2 274	93,5	543,2
0,90	96,7	1,869	405	2 265	96,7	541,2
1,00	99,6	1,694	417	2 257	99,7	539,3
1,50	111,4	1,159	467	2 226	111,5	531,8
2,00	120,2	0,8854	504	2 201	120,5	525,9
2,50	127,4	0,7184	535	2 181	127,8	521,0
3,00	133,5	0,6056	561	2 163	134,1	516,7
3,50	138,9	0,5240	584	2 147	139,5	512,9
4,00	143,6	0,4622	604	2 133	144,4	509,5
4,50	147,9	0,4138	623	2 119	148,8	506,3
5,00	151,8	0,3747	640	2 107	152,8	503,4
6,00	158,8	0,3155	670	2 084	160,1	498,0
7,00	164,9	0,2727	696	2 065	166,4	493,3
8,00	170,4	0,2403	721	2 046	172,2	488,8
9,00	175,4	0,2148	742	2 029	177,3	484,8
10,00	179,9	0,1943	762	2 013	182,1	481,0
11,00	184,1	0,1774	778	1 998	186,5	477,4
12,00	188,0	0,1632	798	1 983	190,7	473,9
13,00	191,6	0,1511	814	1 970	194,5	470,8
14,00	195,0	0,1407	830	1 958	198,2	467,7
15,00	198,3	0,1317	844	1 945	201,7	464,7
16,00	201,4	0,1237	858	1 933	205,1	461,7
17,00	204,3	0,1166	871	1 921	208,2	459,0
18,00	207,1	0,1103	884	1 910	211,2	456,3
19,00	209,8	0,10470	897	1 899	214,2	453,6
20,00	212,4	0,09954	908	1 888	217,0	451,1
25,00	223,9	0,07991	961	1 839	229,7	439,3
30,00	233,8	0,06663	1008	1 794	240,8	428,5
40,00	250,3	0,04975	1087	1 712	259,7	409,1
50,00	263,9	0,03943	1154	1 640	275,7	391,7
60,00	275,6	0,03244	1213	1 571	289,8	375,4
70,00	285,8	0,02737	1267	1 505	302,7	359,7
80,00	295,0	0,02353	1317	1 442	314,6	344,6
90,00	303,3	0,02050	1363	1 380	325,7	329,8
100,00	311,0	0,01804	1407	1 319	336,3	315,2
110,00	318,1	0,01601	1450	1 258	346,5	300,6
120,00	324,7	0,01428	1492	1 197	356,3	286,0
130,00	330,8	0,01280	1532	1 135	365,9	271,1
140,00	336,6	0,01150	1571	1 070	375,4	255,7
150,00	342,1	0,010340	1610	1 004	384,7	239,9
200,00	365,7	0,005877	1826	592	436,2	141,4

1 kcal = 4,186 kJ  
1 kJ = 0,24 kcal

## Flash (Secondary) Steam

**What is flash steam?** When hot condensate or boiler water, under pressure, is released to a lower pressure, part of it is re-evaporated, becoming what is known as flash steam.

**Why is it important?** This flash steam is important because it contains heat units that can be used for economical plant operation – and which are otherwise wasted.

**How is it formed?** When water is heated at atmospheric pressure (1,013 bar(a)), its temperature rises until it reaches 100°C, the highest temperature at which water can exist at this pressure. Additional heat does not raise the temperature, but converts the water to steam.

The heat absorbed by the water in raising its temperature to boiling point is called “sensible heat” or heat of saturated liquid. The heat required to convert water at boiling point to steam at the same temperature is called “latent heat.” The unit of heat in common use is the kJ. The amount of heat required to raise the temperature of one kg of water by 1°C at atmospheric pressure equals 4,186 kJ.

If water is heated under pressure, however, the boiling point is higher than 100°C, so the sensible heat required is greater. The higher the pressure, the higher the boiling temperature and the higher the heat content. If pressure is reduced, a certain amount of sensible heat is released. This excess heat will be absorbed in the form of latent heat, causing part of the water to “flash” into steam.

Condensate at steam temperature and under 10 bar(a) pressure has a heat content of 762 kJ/kg. (See Column 4 in Steam Table.) If this condensate is discharged to atmospheric pressure (1 bar(a)), its heat content instantly drops to 417 kJ/kg. The surplus of 345 kJ reevaporates or flashes a portion of the condensate. The percentage that will flash to steam can be computed using the formula:

$$\% \text{ flash steam} = \frac{q_1 - q_2}{r} \times 100$$

- $q_1$  = Sensible heat in the condensate at the higher pressure before discharge.
- $q_2$  = Sensible heat in the condensate at the lower pressure to which discharge takes place.
- $r$  = Latent heat in the steam at the lower pressure to which the condensate has been discharged.

$$\% \text{ flash steam} = \frac{762 - 417}{2\,257} \times 100 = 15,3\%$$

Chart CG-11-1 shows the amount of secondary steam that will be formed when discharging condensate to different pressures. **Other useful tables can be found on page CG-61 (Useful Engineering Tables).**

Chart CG-11-1. Percentage of flash steam formed when discharging condensate to reduced pressure.

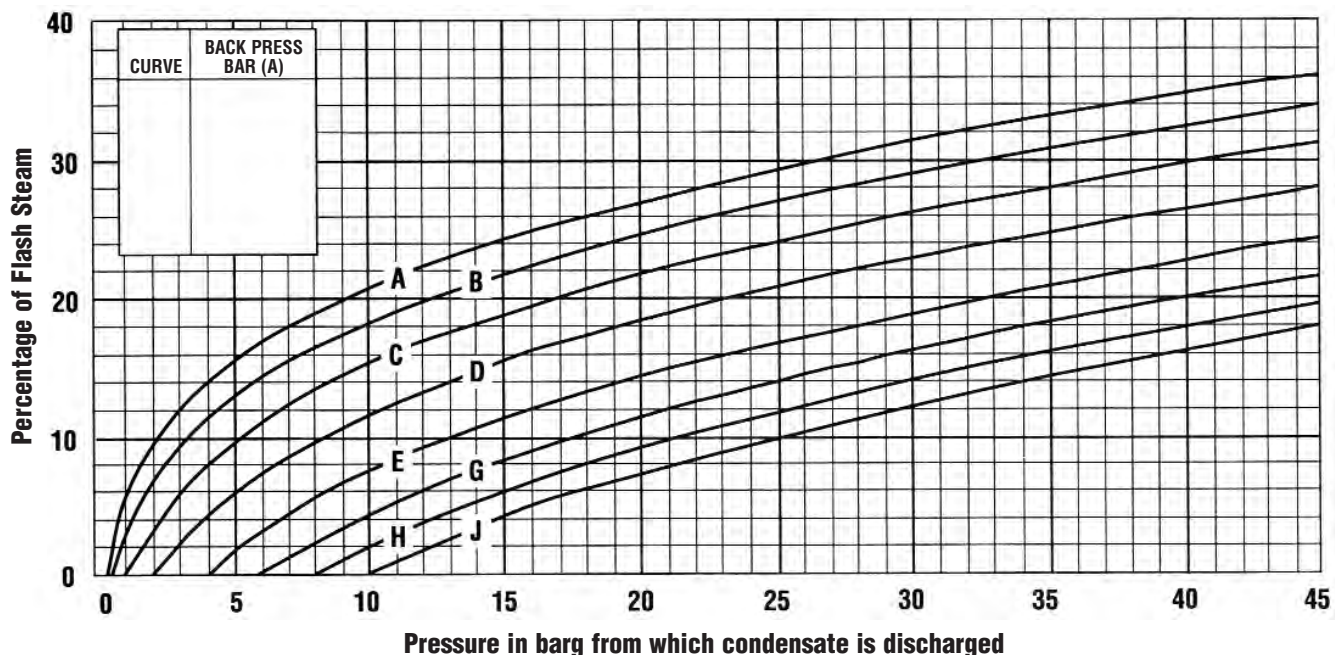



# Steam...Basic Concepts

Steam Conservation Guidelines

Steam is an invisible gas generated by adding heat energy to water in a boiler. Enough energy must be added to raise the temperature of the water to the boiling point. Then additional energy – without any further increase in temperature – changes the water to steam.

Steam is a very efficient and easily controlled heat transfer medium. It is most often used for transporting energy from a central location (the boiler) to any number of locations in the plant where it is used to heat air, water or process applications.

As noted, additional kJ are required to make boiling water change to steam. These kJ are not lost but stored in the steam ready to be released to heat air, cook tomatoes, press pants or dry a roll of paper.

The heat required to change boiling water into steam is called the heat of vaporization or latent heat. The quantity is different for every pressure/temperature combination, as shown in the steam tables.

## Steam at Work...

### How the Heat of Steam Is Utilized

Heat flows from a higher temperature level to a lower temperature level in a process known as heat transfer. Starting in the combustion chamber of the boiler, heat flows through the boiler tubes to the water. When the higher pressure in the boiler pushes steam out, it heats the pipes of the distribution system. Heat flows from the steam through the walls of the pipes into the cooler surrounding air. This heat transfer changes some of the steam back into water. That's why distribution lines are usually insulated to minimize this wasteful and undesirable heat transfer.

When steam reaches the heat exchangers in the system, the story is different. Here the transfer of heat from the steam is

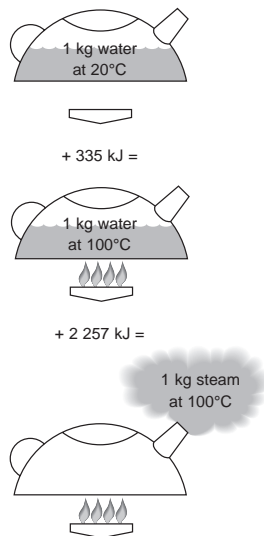

**Figure CG-12-1.** These drawings show how much heat is required to generate one kg of steam at atmospheric pressure. Note that it takes 4,186 kJ for every 1°C increase in temperature up to the boiling point, but that it takes much more kJ to change water at 100°C to steam at 100°C.

desirable. Heat flows to the air in an air heater, to the water in a water heater or to food in a cooking kettle. Nothing should interfere with this heat transfer.

## Condensate Drainage...

### Why It's Necessary

Condensate is the by-product of heat transfer in a steam system. It forms in the distribution system due to unavoidable radiation. It also forms in heating and process equipment as a result of desirable heat transfer from the steam to the substance heated. Once the steam has condensed and given up its valuable latent heat, the hot condensate must be removed immediately. Although the available heat in a kilogram of condensate is negligible as compared to a kilogram of steam, condensate is still valuable hot water and should be returned to the boiler.

## Definitions

- **The kJ.** 4,186 kJ – kilojoules – is the amount of heat energy required to raise the temperature of one kg of cold water by 1°C. Or, 4,186 kJ is the amount of heat energy given off by one kg of water in cooling, say, from 20°C to 19°C.
- **Temperature.** The degree of hotness with no implication of the amount of heat energy available.
- **Heat.** A measure of energy available with no implication of temperature. To illustrate, the 4,186 kJ that raises one kg of water from 10°C to 11°C could come from the surrounding air at a temperature of 20°C or from a flame at a temperature of 500°C.

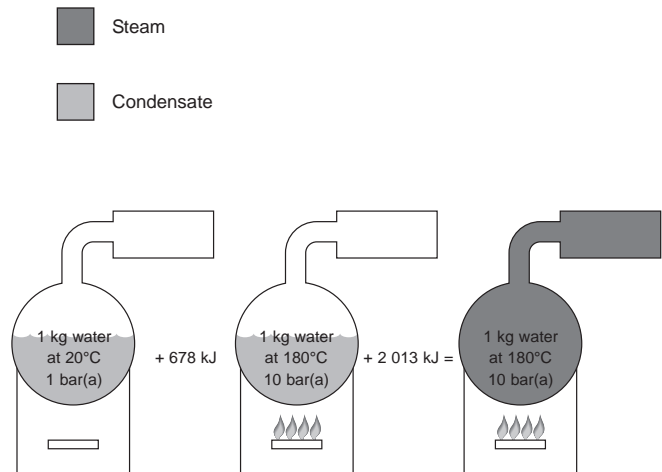

**Figure CG-12-2.** These drawings show how much heat is required to generate one kg of steam at 10 bar(a) pressure. Note the extra heat and higher temperature required to make water boil at 10 bar(a) pressure than at atmospheric pressure. Note, too, the lesser amount of heat required to change water to steam at the higher temperature.

**The need to drain the distribution system.** Condensate lying in the bottom of steam lines can be the cause of one kind of water hammer. Steam traveling at up to 150 km per hour makes “waves” as it passes over this condensate (Fig. CG-13-2). If enough condensate forms, high-speed steam pushes it along, creating a dangerous slug that grows larger and larger as it picks up liquid in front of it. Anything that changes the direction – pipe fittings, regulating valves, tees, elbows, blind flanges – can be destroyed. In addition to damage from this “battering ram,” high-velocity water may erode fittings by chipping away at metal surfaces.

**The need to drain the heat transfer unit.** When steam comes in contact with condensate cooled below the temperature of steam, it can produce another kind of water hammer known as *thermal shock*. Steam occupies a much greater volume than condensate, and when it collapses suddenly, it can send shock waves throughout the system. This form of water hammer can damage equipment, and it signals that condensate is not being drained from the system.

Obviously, condensate in the heat transfer unit takes up space and reduces the physical size and capacity of the equipment. Removing it quickly keeps the unit full of steam (Fig. CG-13-3). As steam condenses, it forms a film of water on the inside of the heat exchanger. Non-condensable gases do not change into liquid and flow away by gravity. Instead, they accumulate as a thin film on the surface of the heat exchanger – along with dirt and scale. All are potential barriers to heat transfer (Fig. CG-13-1)

**The need to remove air and CO<sub>2</sub>.** Air is always present during equipment start-up and in the boiler feedwater. Feedwater may also contain dissolved carbonates, which release carbon dioxide gas. The steam velocity pushes the gases to the walls of the heat exchangers, where they may block heat transfer. This compounds the condensate drainage problem, because these gases must be removed along with the condensate.

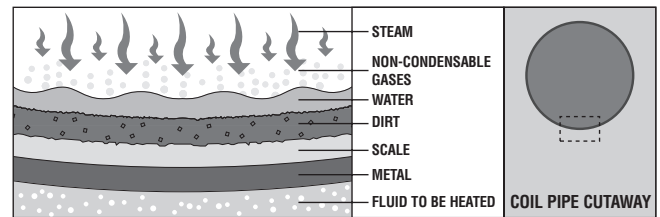

**Figure CG-13-1.** Potential barriers to heat transfer: steam heat and temperature must penetrate these potential barriers to do their work.

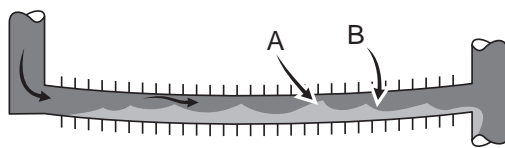

**Figure CG-13-2.** Condensate allowed to collect in pipes or tubes is blown into waves by steam passing over it until it blocks steam flow at point A. Condensate in area B causes a pressure differential that allows steam pressure to push the slug of condensate along like a battering ram.

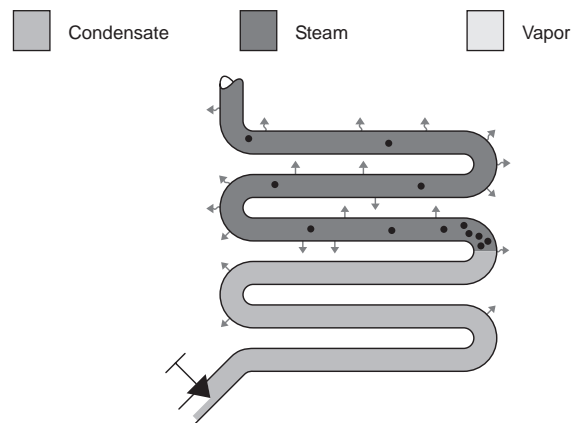

**Figure CG-13-3.** Coil half full of condensate can't work at full capacity.

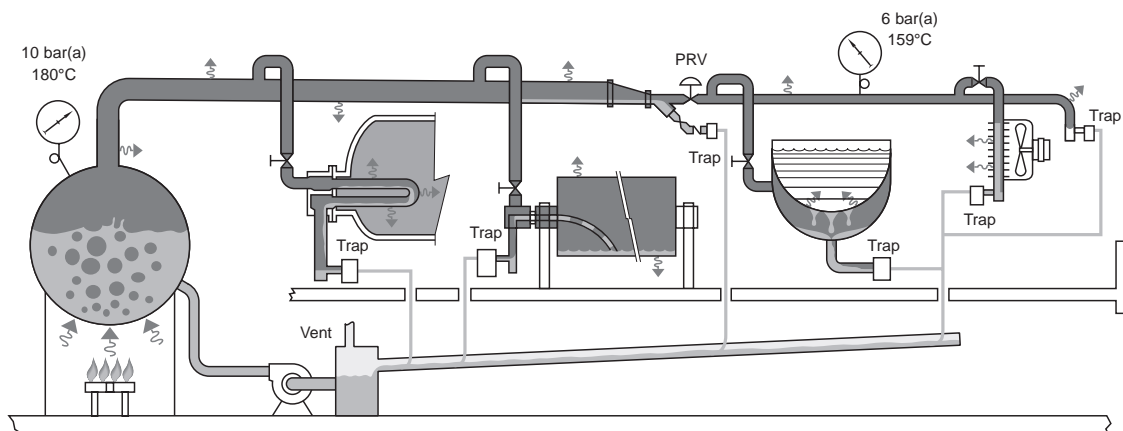

**Figure CG-13-4.** Note that heat radiation from the distribution system causes condensate to form and, therefore, requires steam traps at natural low points or ahead of control valves. In the heat exchangers, traps perform the vital function of removing the condensate before it becomes a barrier to heat transfer. Hot condensate is returned through the traps to the boiler for reuse.

## Effect of Air on Steam Temperature

When air and other gases enter the steam system, they consume part of the volume that steam would otherwise occupy. The temperature of the air/steam mixture falls below that of pure steam. Figure CG-14-1 explains the effect of air in steam lines. Table CG-14-1 and Chart CG-14-1 show the various temperature reductions caused by air at various percentages and pressures.

## Effect of Air on Heat Transfer

The normal flow of steam toward the heat exchanger surface carries air and other gases with it. Since they do not condense and drain by gravity, these non-condensable gases set up a barrier between the steam and the heat exchanger surface. The excellent insulating properties of air reduce heat transfer. In fact, under certain conditions as little as 1/2 of 1% by volume of air in steam can reduce heat transfer efficiency by 50% (Fig. CG-15-1).

When non-condensable gases (primarily air) continue to accumulate and are not removed, they may gradually fill the heat exchanger with gases and stop the flow of steam altogether. The unit is then "air bound."

Table CG-14-1. Temperature Reduction Caused by Air				
Pressure (bar(a))	Temp. of Steam, No Air Present (°C)	Temp. of steam Mixed with Various Percentages of Air (by Volume) (°C)		
		10%	20%	30%
2	120,2	116,7	113,0	110,0
4	143,6	140,0	135,5	131,1
6	158,8	154,5	150,3	145,1
8	170,4	165,9	161,3	155,9
10	179,9	175,4	170,4	165,0

**Figure CG-14-1.** Chamber containing air and steam delivers only the heat of the partial pressure of the steam, not the total pressure.

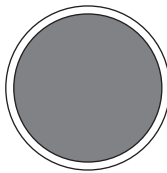

Steam chamber 100% steam  
 Total pressure 10 bar(a)  
 Steam pressure 10 bar(a)  
 Steam temperature 180°C

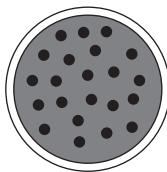

Steam chamber 90% steam and 10% air  
 Total pressure 10 bar(a)  
 Steam pressure 9 bar(a)  
 Steam temperature 175,4°C

## Corrosion

Two primary causes of scale and corrosion are carbon dioxide (CO<sub>2</sub>) and oxygen (O<sub>2</sub>). CO<sub>2</sub> enters the system as carbonates dissolved in feedwater and, when mixed with cooled condensate, creates carbonic acid. Extremely corrosive, carbonic acid can eat through piping and heat exchangers (Fig. CG-15-2). Oxygen enters the system as gas dissolved in the cold feedwater. It aggravates the action of carbonic acid, speeding corrosion and pitting iron and steel surfaces (Fig. CG-15-3).

## Eliminating the Undesirables

To summarize, traps must drain condensate because it can reduce heat transfer and cause water hammer. Traps should evacuate air and other non-condensable gases because they can reduce heat transfer by reducing steam temperature and insulating the system. They can also foster destructive corrosion. It's essential to remove condensate, air and CO<sub>2</sub> as quickly and completely as possible. A steam trap, which is simply an automatic valve that opens for condensate, air and CO<sub>2</sub> and closes for steam, does this job. For economic reasons, the steam trap should do its work for long periods with minimum attention.

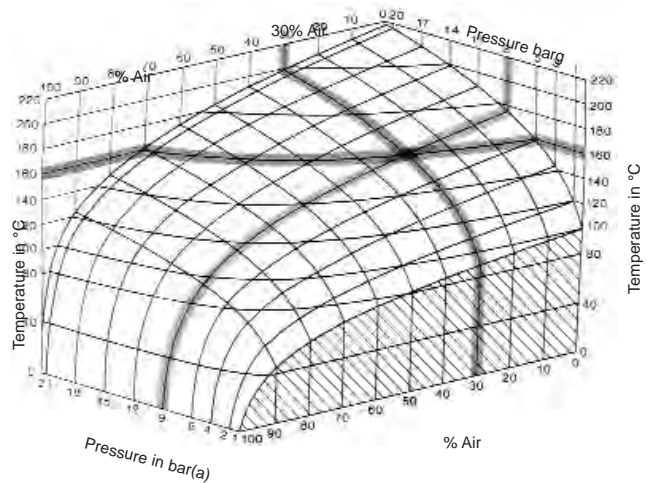

**Chart CG-14-1. Air Steam Mixture**

Temperature reduction caused by various percentages of air at differing pressures. This chart determines the percentage of air with known pressure and temperature by determining the point of intersection between pressure, temperature and percentage of air by volume. As an example, assume system pressure of 9 bar(a) with a temperature at the heat exchanger of 160°C. From the chart, it is determined that there is 30% air by volume in the steam.

## What the Steam Trap Must Do

The job of the steam trap is to get condensate, air and CO<sub>2</sub> out of the system as quickly as they accumulate. In addition, for overall efficiency and economy, the trap must also provide:

- 1. Minimal steam loss.** Table CG-15-1 shows how costly unattended steam leaks can be.
- 2. Long life and dependable service.** Rapid wear of parts quickly brings a trap to the point of unavailability. An efficient trap saves money by minimizing trap testing, repair, cleaning, downtime and associated losses.
- 3. Corrosion resistance.** Working trap parts should be corrosion-resistant in order to combat the damaging effects of acidic or oxygen-laden condensate.
- 4. Air venting.** Air can be present in steam at any time and especially on start-up. Air must be vented for efficient heat transfer and to prevent system binding.
- 5. CO<sub>2</sub> venting.** Venting CO<sub>2</sub> at steam temperature will prevent the formation of carbonic acid. Therefore, the steam trap must function at or near steam temperature since CO<sub>2</sub> dissolves in condensate that has cooled below steam temperature.
- 6. Operation against back pressure.** Pressurized return lines can occur both by design and unintentionally. A steam trap should be able to operate against the actual back pressure in its return system.
- 7. Freedom from dirt problems.** Dirt is an ever-present concern since traps are located at low points in the steam system. Condensate picks up dirt and scale in the piping, and solids may carry over from the boiler. Even particles passing through strainer screens are erosive and, therefore, the steam trap must be able to operate in the presence of dirt.

**Figure CG-15-1.** Steam condensing in a heat transfer unit moves air to the heat transfer surface, where it collects or "plates out" to form effective insulation.

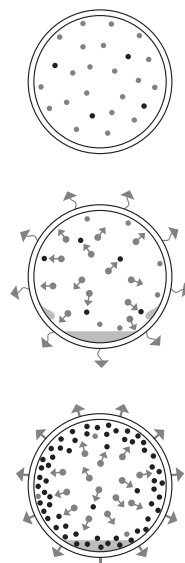

Condensate

Steam

A trap delivering anything less than all these desirable operating/design features will reduce the efficiency of the system and increase costs. When a trap delivers all these features the system can achieve:

1. Fast heat-up of heat transfer equipment
2. Maximum equipment temperature for enhanced steam heat transfer
3. Maximum equipment capacity
4. Maximum fuel economy
5. Reduced labor per unit of output
6. Minimum maintenance and a long trouble-free service life

Sometimes an application may demand a trap without these design features, but in the vast majority of applications the trap which meets all the requirements will deliver the best results.

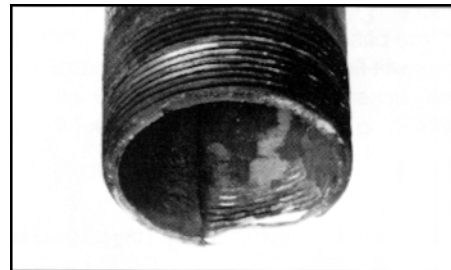

**Figure CG-15-2.** CO<sub>2</sub> gas combines with condensate allowed to cool below steam temperature to form carbonic acid, which corrodes pipes and heat transfer units. Note groove eaten away in the pipe illustrated.

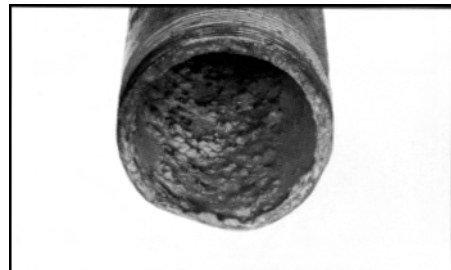

**Figure CG-15-3.** Oxygen in the system speeds corrosion (oxidation) of pipes, causing pitting such as shown here.

Figs. CG-15-2 and CG-15-3 courtesy of Dearborn Chemical Company, USA.

**Table CG-15-1. Cost of Various Sized steam Leaks at 7 barg (Assuming steam costs 10,00€ Per Ton of Steam)**

Size of Orifice (In.)	Tons of Steam Wasted Per Month	Total Cost Per Month (€)	Total Cost Per Year (€)
1/2"	379,5	3 795	45 540
7/16"	289,5	2 895	34 740
3/8"	213,6	2 136	25 632
5/16"	147,7	1 477	17 724
1/4"	95,4	954	11 448
3/16"	53,2	532	6 384
1/8"	23,8	238	2 856

The steam loss values assume clean, dry steam flowing through a sharp-edged orifice to atmospheric pressure with no condensate present. Condensate would normally reduce these losses due to the flashing effect when a pressure drop is experienced.





# The Inverted Bucket Steam Trap

The Armstrong inverted submerged bucket steam trap is a mechanical trap that operates on the difference in density between steam and water. See Fig. CG-16-1. Steam entering the inverted submerged bucket causes the bucket to float and close the discharge valve. Condensate entering the trap changes the bucket to a weight that sinks and opens the trap valve to discharge the condensate. Unlike other mechanical traps, the inverted bucket also vents air and carbon dioxide continuously at steam temperature.

This simple principle of condensate removal was introduced by Armstrong in 1911. Years of improvement in materials and manufacturing have made today's Armstrong inverted bucket traps virtually unmatched in operating efficiency, dependability and long life.

### Long, Energy-Efficient Service Life

At the heart of the Armstrong inverted bucket trap is a unique leverage system that multiplies the force provided by the bucket to open the valve against pressure. There are no fixed pivots to wear or create friction. It is designed to open the discharge orifice for maximum capacity. Since the bucket is open at the bottom, it is resistant to damage from water hammer. Wearing points are heavily reinforced for long life.

An Armstrong inverted bucket trap can continue to conserve energy even in the presence of wear. Gradual wear slightly increases the diameter of the seat and alters the shape and diameter of the ball valve. But as this occurs, the ball merely seats itself deeper – preserving a tight seal.

### Reliable Operation

The Armstrong inverted bucket trap owes much of its reliability to a design that makes it virtually free of dirt problems. Note that the valve and seat are at the top of the trap. The larger particles of dirt fall to the bottom, where they are pulverized under the up-and-down action of the bucket. Since the valve of an inverted bucket is either closed or fully open, there is free passage of dirt particles. In addition, the swift flow of condensate from under the bucket's edge creates a unique self-scrubbing action that sweeps dirt out of the trap. The inverted bucket has only two moving parts – the valve lever assembly and the bucket. That means no fixed points, no complicated linkages – nothing to stick, bind or clog.

### Corrosion-Resistant Parts

The valve and seat of Armstrong inverted bucket traps are high chrome stainless steel, ground and lapped. All other working parts are wear- and corrosion-resistant stainless steel.

### Operation Against High Back Pressure

High pressure in the discharge line simply reduces the differential across the valve. As back pressure approaches that of inlet pressure, discharge becomes continuous just as it does on the very low pressure differentials.

Back pressure has no adverse effect on inverted bucket trap operation other than capacity reduction caused by the low differential. There is simply less force required by the bucket to pull the valve open, cycling the trap.

Figure CG-16-1. Operation of Inverted Bucket Steam Trap (at pressures close to maximum)

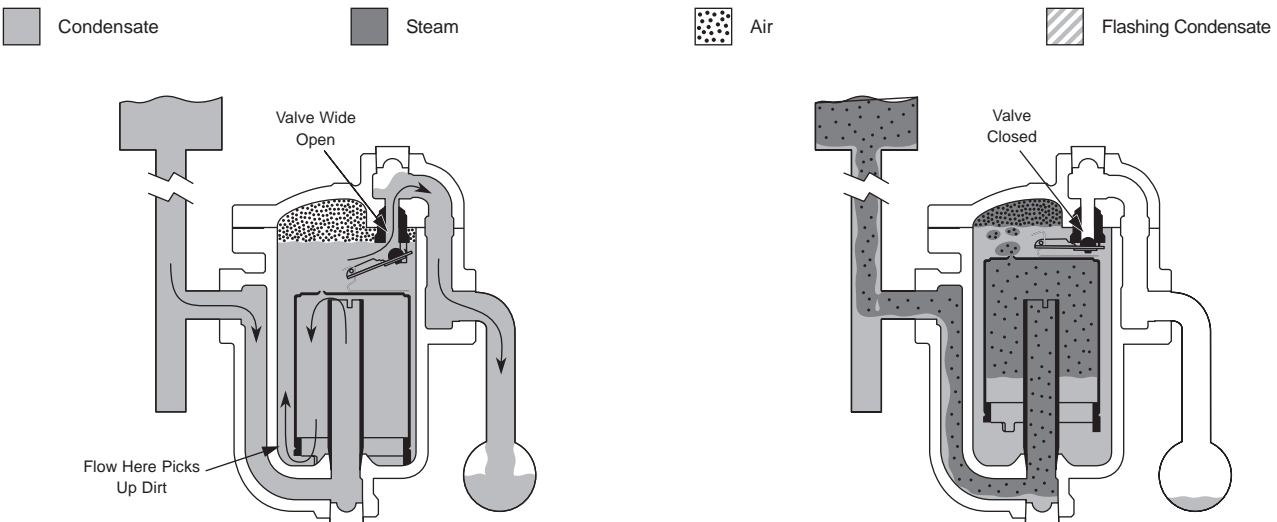

1. Steam trap is installed in drain line between steam-heated unit and condensate return header. On start-up, bucket is down and valve is wide open. As initial flood of condensate enters the trap and flows under bottom of bucket, it fills trap body and completely submerges bucket. Condensate then discharges through wide-open valve to return header.

2. Steam also enters trap under bottom of bucket, where it rises and collects at top, imparting buoyancy. Bucket then rises and lifts valve toward its seat until valve is snapped tightly shut. Air and carbon dioxide continually pass through bucket vent and collect at top of trap. Any steam passing through vent is condensed by radiation from trap.

# The Inverted Bucket Steam Trap

## Types of Armstrong Inverted Bucket Traps Available to Meet Specific Requirements

The availability of inverted bucket traps in different body materials, piping configurations and other variables permits flexibility in applying the right trap to meet specific needs. See Table CG-17-1.

- 1. All-Stainless Steel Traps.** Sealed, tamper-proof stainless steel bodies enable these traps to withstand freeze-ups without damage. They may be installed on tracer lines, outdoor drips and other services subject to freezing. For pressures to 45 barg and temperatures to 427°C.
- 2. Cast Iron Traps.** Standard inverted bucket traps for general service at pressures to 17 barg and temperatures to 232°C. Offered with side connections, side connections with integral strainers and bottom inlet – top outlet connections.
- 3. Forged Steel Traps.** Standard inverted bucket traps for high pressure, high temperature services (including superheated steam) to 186 barg at 560°C.
- 4. Cast Stainless Steel Traps.** Standard inverted bucket traps for high capacity, corrosive service. Repairable. For pressures to 47 barg and temperatures to 263°C.

Table CG-17-1. Typical Design Parameters for Inverted Bucket traps					
Body and Cap Materials	Cast Iron	Stainless Steel	Forged Steel	Cast Steel	Cast Stainless Steel
Connections (mm)	15 - 65	15 - 25	15 - 50	15 - 25	15 - 50
Type Connections	Screwed, Flanged	Screwed, Socketweld or Flanged	Screwed, Socketweld or Flanged	Screwed, Socketweld or Flanged	Screwed, Socketweld or Flanged
Operating Pressure (barg)	0 thru 17	0 thru 45	0 thru 180	0 thru 40	0 thru 47
Capacity (kg/h)	To 9 500	To 2 000	To 9 500	To 2 000	To 9 500

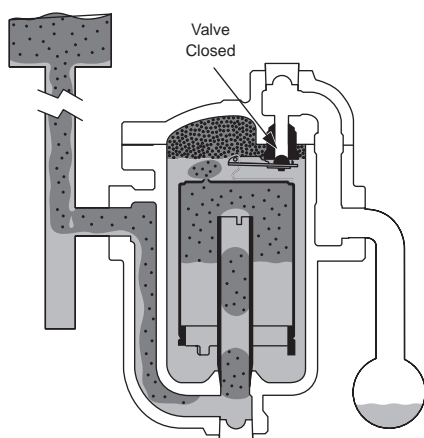

3. As the entering condensate starts to fill the bucket, the bucket begins to exert a pull on the lever. As the condensate continues to rise, more force is exerted until there is enough to open the valve against the differential pressure.

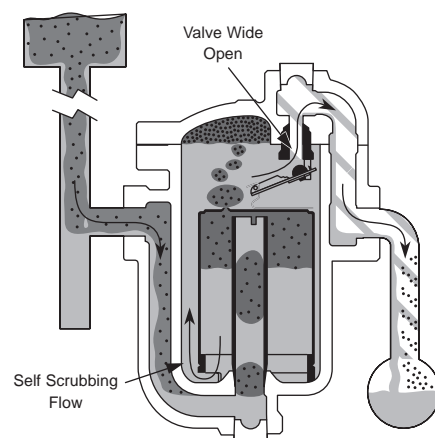

4. As the valve starts to open, the pressure force across the valve is reduced. The bucket then sinks rapidly and fully opens the valve. Accumulated air is discharged first, followed by condensate. The flow under the bottom of the bucket picks up dirt and sweeps it out of the trap. Discharge continues until more steam floats the bucket, and the cycle repeats.



# The Float and Thermostatic Steam Trap

The float and thermostatic trap is a mechanical trap that operates on both density and temperature principles. The float valve operates on the density principle: a lever connects the ball float to the valve and seat. Once condensate reaches a certain level in the trap the float rises, opening the orifice and draining condensate. A water seal formed by the condensate prevents live steam loss.

Since the discharge valve is under water, it is not capable of venting air and non-condensables. When the accumulation of air and non-condensable gases causes a significant temperature drop, a thermostatic air vent in the top of the trap discharges it. The thermostatic vent opens at a temperature a few degrees below saturation so it's able to handle a large volume of air – through an entirely separate orifice – but at a slightly reduced temperature.

Armstrong F&T traps provide high air-venting capacity, respond immediately to condensate and are suitable for both industrial and HVAC applications.

### Reliable Operation on Modulating Steam Pressure

Modulating steam pressure means that the pressure in the heat exchange unit being drained can vary anywhere from the maximum steam supply pressure down to vacuum under certain conditions. Thus, under conditions of zero pressure, only the force of gravity is available to push condensate through a steam trap. Substantial amounts of air may also be liberated under these conditions of low steam pressure. The efficient operation of the F&T trap meets all of these specialized requirements.

### High Back Pressure Operation

Back pressure has no adverse effect on float and thermostatic trap operation other than capacity reduction due to low differential. The trap will not fail to close and will not blow steam due to the high back pressure.

Table CG-18-1. Typical Design Parameters for Float and Thermostatic Traps

Body and Cap Materials	Cast Iron	Cast Steel
Connections (mm)	15 - 80	15 - 80
Type Connections	Screwed or Flanged	Screwed, Socketweld or Flanged
Operating Pressure (bar)	0 thru 17	0 thru 31
Capacity (kg/h)	To 94 000	To 170 000

Figure CG-18-1. Operation of F&T Steam Trap

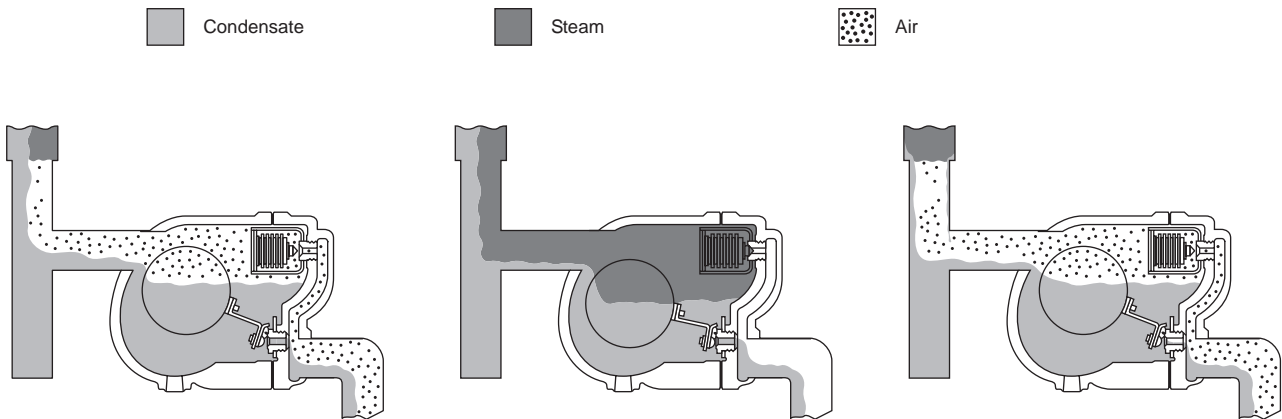

1. On start-up, low system pressure forces air out through the thermostatic air vent. A high condensate load normally follows air venting and lifts the float, which opens the main valve. The remaining air continues to discharge through the open vent.

2. When steam reaches the trap, the thermostatic air vent closes in response to higher temperature. Condensate continues to flow through the main valve, which is positioned by the float to discharge condensate at the same rate that it flows to the trap.

3. As air accumulates in the trap, the temperature drops below that of saturated steam. The balanced pressure thermostatic air vent opens and discharges air.

**NOTE:** These operational schematics of the F&T trap do not represent actual trap configuration.

# The Controlled Disc Steam Trap

The controlled disc steam trap is a time-delayed device that operates on the velocity principle. It contains only one moving part, the disc itself. Because it is very lightweight and compact, the CD trap meets the needs of many applications where space is limited. In addition to the disc trap's simplicity and small size, it also offers advantages such as resistance to hydraulic shock, the complete discharge of all condensate when open and intermittent operation for a steady purging action.

## Unique Heating Chamber

The unique heating chamber in Armstrong's controlled disc traps surrounds the disc body and control chamber. A controlled bleed from the chamber to the trap outlet controls the cycle rate. That means that the trap design – not ambient conditions – controls the cycle rate. Without this controlling feature, rain, snow and cold ambient conditions would upset the cycle rate of the trap.

**Figure CG-19-1. Operation of Controlled Disc Traps**

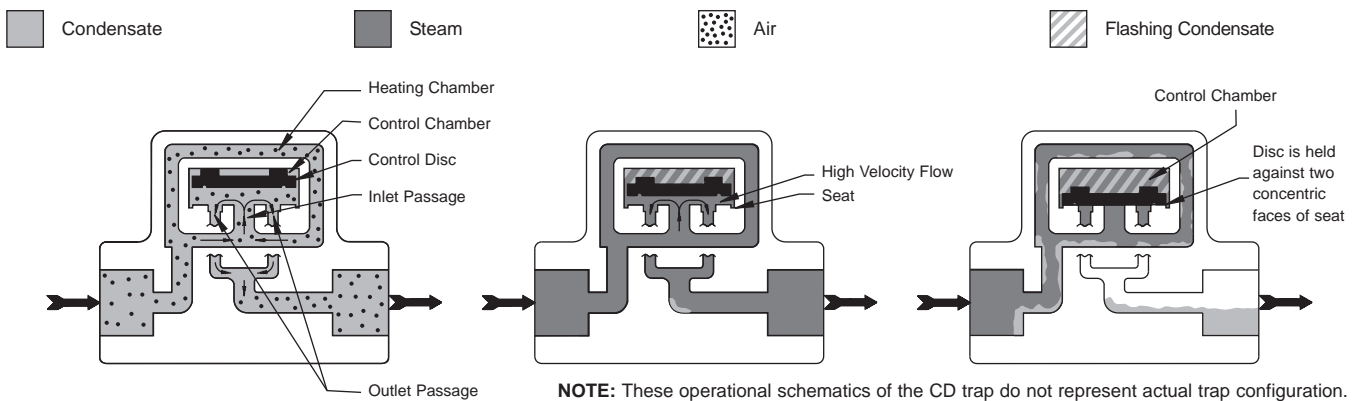

1. On start-up, condensate and air entering the trap pass through the heating chamber, around the control chamber and through the inlet orifice. This flow lifts the disc off the inlet orifice, and the condensate flows through to the outlet passages.

2. Steam enters through the inlet passage and flows under the control disc. The flow velocity across the face of the control disc increases, creating a low pressure that pulls the disc toward the seat.

3. The disc closes against two concentric faces of the seat, closing off the inlet passage and also trapping steam and condensate above the disc. There is a controlled bleeding of steam from the control chamber; flashing condensate helps maintain the pressure in the control chamber. When the pressure above the disc is reduced, the incoming pressure lifts the disc off the seat. If condensate is present, it will be discharged, and the cycle repeats.

**Table CG-19-1. Typical Design Parameter of Controlled Disc Steam Traps**

Body and Cap Materials	Carbon Steel	Stainless Steel
Connections (mm)	10 - 25	15 - 25
Type Connections	Screwed, Socketweld or Flanged	Screwed or Flanged
Operating Pressure (bar)	0 thru 41	0 thru 41
Capacity (kg/h)	To 1 300	To 1 150

# The Bimetallic Steam Trap

The bimetallic steam trap operates on the temperature principle, using two layers of bimetallic elements, which have different expansion coefficients. When cold, the bimetallic elements are flat. When the temperature starts to rise, the elements will expand differently and will curve. The stem connected to these elements moves a valve into either an open or closed position.

**Figure CG-19-2. Operation of Bimetallic Steam Traps**

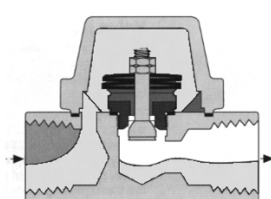

1. On start-up, temperature is low and the bimetallic elements are flat. The valve is opened and condensate and air are discharged through the trap.

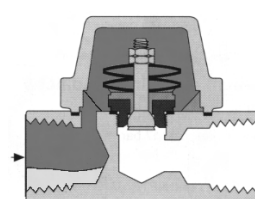

2. When steam reaches the trap, the temperature increases and the bimetallic elements are expanding. The valve will close and the trap stops discharging until enough subcooled condensate is accumulated and temperature decreases.

**Table CG-19-2. Typical Design Parameter for Bimetallic Traps**

Body and Cap Materials	Carbon steel and Stainless steel
Connections (mm)	15 - 20
Type Connections	Screwed, Socketweld or Flanged
Operating Pressure (barg)	0 thru 24
Capacity (kg/h)	To 1 200



# The Thermostatic Steam Trap

Steam Conservation Guidelines

Armstrong thermostatic steam traps are available with balanced pressure bellows or wafer-type elements and are constructed in a wide variety of materials, including stainless steel, carbon steel and bronze. These traps are used on applications with very light condensate loads.

## Thermostatic Operation

Thermostatic steam traps operate on the difference in temperature between steam and cooled condensate and air. Steam increases the pressure inside the thermostatic element, causing the trap to close. As condensate and non-condensable gases back up in the cooling leg, the temperature begins to drop, and the thermostatic element contracts and opens the valve. The amount of condensate backed up ahead of the trap depends on the load conditions, steam pressure and size of the piping. It is important to note that an accumulation of non-condensable gases can occur behind the condensate backup.

	Balanced Pressure Bellows		Balanced Pressure Water		
	Stainless Steel	Bronze	Stainless Steel	Carbon Steel	Bronze
Body and Cap Material	Stainless Steel	Bronze	Stainless Steel	Carbon Steel	Bronze
Connections	15 - 20	15 - 20	10 - 25	15 - 20	15 - 25
Type Connections	Screwed, Socketweld	Screwed, Straight, Angle	Screwed, Socketweld	Screwed, Socketweld	Screwed, Straight, Angle
Operating Pressure (barg)	0 - 20	0 - 3	0 - 27	0 - 40	0 - 4
Capacity (kg/h)	To 1 600	To 750	To 30	To 40	To 450

**NOTE:** Thermostatic traps can also be used for venting air from a steam system. When air collects, the temperature drops and the thermostatic air vent automatically discharges the air at slightly below steam temperature throughout the entire operating pressure range.

Figure CG-20-1. Operation of Thermostatic Steam Trap

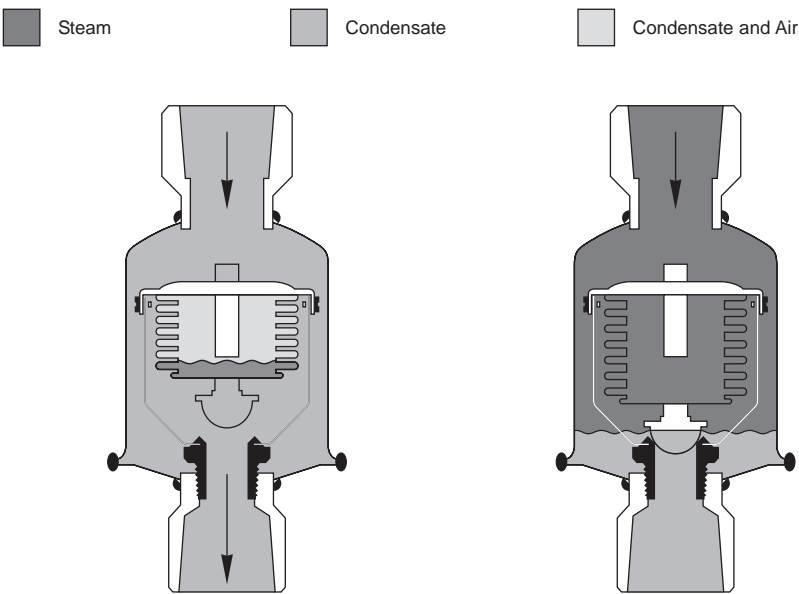

1. On start-up, condensate and air are pushed ahead of the steam directly through the trap. The thermostatic bellows element is fully contracted, and the valve remains wide open until steam approaches the trap.

2. As the temperature inside the trap increases, it quickly heats the charged bellows element, increasing the vapor pressure inside. When pressure inside the element becomes balanced with system pressure in the trap body, the spring effect of the bellows causes the element to expand, closing the valve. When temperature in the trap drops a few degrees below saturated steam temperature, imbalanced pressure contracts the bellows, opening the valve.

Figure CG-20-2. Operation of Thermostatic Wafer

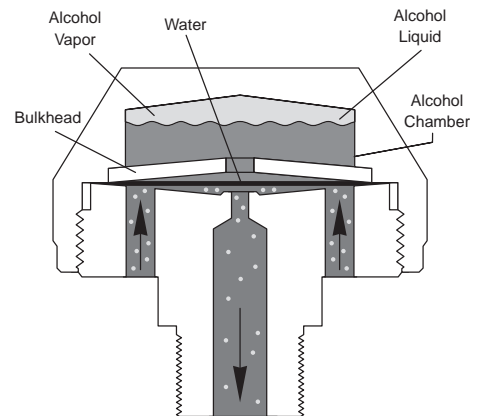

Balanced Pressure Thermostatic Wafer operation is very similar to balanced pressure bellows described in Fig. CG-20-1. The wafer is partially filled with a liquid. As the temperature inside the trap increases, it heats the charged wafer, increasing the vapor pressure inside. When the pressure inside the wafer exceeds the surrounding steam pressure, the wafer membrane is forced down on the valve seat, and the trap is closed. A temperature drop caused by condensate or non-condensable gases cools and reduces the pressure inside the wafer, allowing the wafer to uncover the seat.

# The Automatic Differential Condensate Controller



Armstrong automatic differential condensate controllers (DC) are designed to function on applications where condensate must be lifted from a drain point or in gravity drainage applications where increased velocity will aid in drainage.

Lifting condensate from the drain point – often referred to as syphon drainage – reduces the pressure of condensate, causing a portion of it to flash into steam. Since ordinary steam traps are unable to distinguish flash steam and live steam, they close and impede drainage.

Increased velocity with gravity drainage will aid in drawing the condensate and air to the DC. An internal steam by-pass controlled by a manual metering valve causes this increased velocity. Therefore, the condensate controller automatically vents the by-pass or secondary steam. This is then collected for use in other heat exchangers or discharged to the condensate return line.

Capacity considerations for draining equipment vary greatly according to the application. However, a single condensate controller provides sufficient capacity for most applications.

## Condensate Controller Operation

Condensate, air and steam (live and flash) enter through the controller inlet. At this point flash steam and air are automatically separated from the condensate. Then they divert into the integral by-pass at a controlled rate, forming secondary steam (See Fig. CG-21-2).

The valve is adjustable so it matches the amount of flash present under full capacity operation or to meet the velocity requirements of the system. The condensate discharges through a separate orifice controlled by the inverted bucket.

Because of the dual orifice design, there is a preset controlled pressure differential for the secondary steam system, while maximum pressure differential is available to discharge the condensate.

Figure CG-21-1.

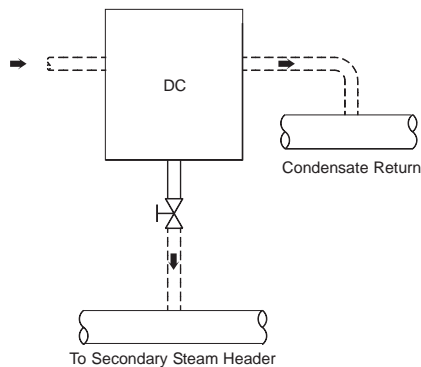

For the most efficient use of steam energy, Armstrong recommends this piping arrangement when secondary steam is collected and reused in heat transfer equipment.

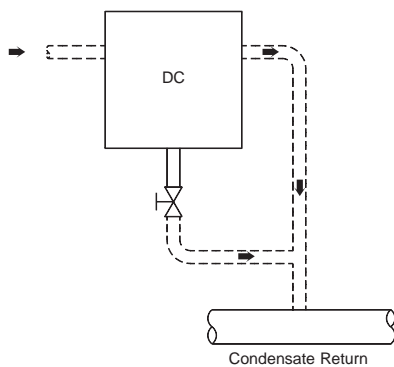

Piping arrangement when flash steam and non-condensables are to be removed and discharged directly to the condensate return line.

Table CG-21-1. Typical design Parameters for the Automatic Differential Condensate Controller

Body and Cap Materials	Cast Iron	Steel
Connections (mm)	15 - 50	15 - 80
Type Connections	Screwed or Flanged	Screwed or Flanged
Operating Pressure (bar)	0 thru 19	0 thru 41
Capacity (kg/h)	To 94 000	To 170 000

Figure CG-21-2. Condensate Controller Operation

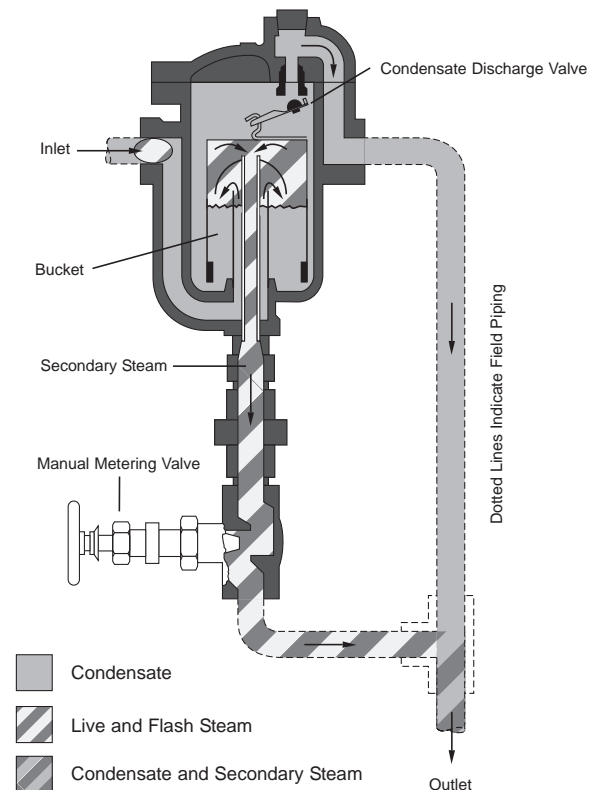

To obtain the full benefits from the traps described in the preceding section, it is essential to select traps of the correct size and pressure for a given job and to install and maintain them properly. One of the purposes of this section is to supply the information to make that possible. Actual installation and operation of steam trapping equipment should be performed only by experienced personnel. Selection or installation should always be accompanied by competent technical assistance or advice. This section should never be used as a substitute for such technical advice or assistance. We encourage you to contact Armstrong or its local representative for further details.

## Basic Considerations

Unit trapping is the use of a separate steam trap on each steam-condensing unit including, whenever possible, each separate chest or coil of a single machine. The discussion under the Short Circuiting heading explains the "why" of unit trapping versus group trapping.

**Rely on experience.** Select traps with the aid of experience – either yours, the know-how of your Armstrong Representative or what others have learned in trapping similar equipment.

**Do-it-yourself sizing.** Do-it-yourself sizing is simple with the aid of Armstrong "Trap-A-Ware" Sizing and Selection software, which can be ordered on [www.armstrong.be](http://www.armstrong.be).

Even without this computer program, you can easily size steam traps when you know or can calculate:

1. Condensate loads in kg/h
2. The safety factor to use
3. Pressure differential
4. Maximum allowable pressure

1. **Condensate load.** Each "How To" portion of this section contains formulas and useful information on steam condensing rates and proper sizing procedures.
2. **Safety factor or experience factor to use.** Users have found that they must generally use a safety factor in sizing steam traps. For example, a coil condensing 300 kg/h might require a trap that could handle up to 900 kg/h for best overall performance. This 3:1 safety factor takes care of varying condensate rates, occasional drops in pressure differential and system design factors.

Safety factors will vary from a low of 1.5:1 to a high of 10:1. The safety factors in this book are based on years of user experience.

*Configuration affects safety factor.* More important than ordinary load and pressure changes is the design of the steam-heated unit itself. Refer to Figs. CG-22-3, CG-22-4 and CG-22-5 showing three condensing units each producing 300 kg of condensate per hour, but with safety factors of 2:1, 3:1 and 8:1.

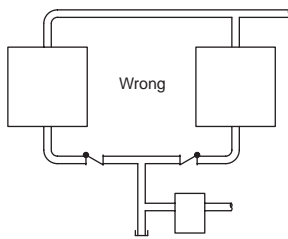

**Figure CG-22-1.** Two steam-consuming units drained by a single trap, referred to as group trapping, may result in short circuiting.

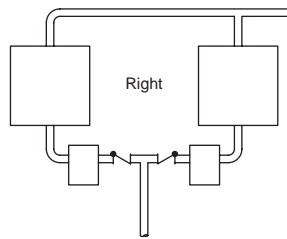
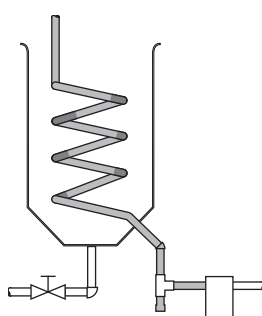

**Figure CG-22-2.** Short circuiting is impossible when each unit is drained by its own trap. Higher efficiency is assured.

## Short Circuiting

If a single trap connects more than one drain point, condensate and air from one or more of the units may fail to reach the trap. Any difference in condensing rates will result in a difference in the steam pressure drop. A pressure drop difference too small to register on a pressure gauge is enough to let steam from the higher pressure unit block the flow of air or condensate from the lower pressure unit. The net result is reduced heating, output and fuel waste (see Figs. CG-22-1 and CG-22-2).

## Identical Condensing Rates, Identical Pressures With Differing Safety Factors



**Figure CG-22-3.** Continuous coil, constant pressure gravity flow to trap. 300 kg/h of condensate from a single copper coil at 3 barg. Gravity drainage to trap. Volume of steam space very small. 2:1 safety factor.

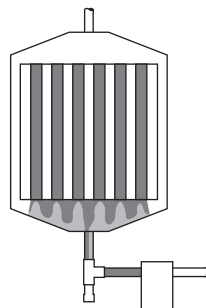

**Figure CG-22-4.** Multiple pipes, modulated pressure gravity flow to trap. 300 kg/h of condensate from unit heater at 5 barg. Multiple tubes create minor short-circuiting hazard. Use 3:1 safety factor at 2,5 barg.

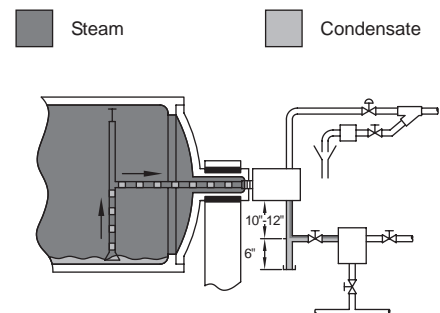

**Figure CG-22-5.** Large cylinder, syphon drained. 300 kg/h from a 1 200 mm diameter, 2 500 mm long cylinder dryer with 2,8 m<sup>3</sup> of space at 2 barg. The safety factor is 3:1 with a DC and 8:1 with an IB.

# Trap Selection



*Economical steam trap/orifice selection.* While an adequate safety factor is needed for best performance, too large a factor causes problems. In addition to higher costs for the trap and its installation, a needlessly oversized trap wears out more quickly. And in the event of a trap failure, an oversized trap loses more steam, which can cause water hammer and high back pressure in the return system.

**3. Pressure differential.** *Maximum differential* is the difference between boiler or steam main pressure or the downstream pressure of a PRV and return line pressure. See Fig. CG-23-1. The trap must be able to open against this pressure differential.

**NOTE:** Because of flashing condensate in the return lines, don't assume a decrease in pressure differential due to static head when elevating.

*Operating differential.* When the plant is operating at capacity, the steam pressure at the trap inlet may be lower than steam main pressure. And the pressure in the condensate return header may go above atmospheric.

If the operating differential is at least 80% of the maximum differential, it is safe to use maximum differential in selecting traps.

Modulated control of the steam supply causes wide changes in pressure differential. The pressure in the unit drained may fall to atmospheric or even lower (vacuum). This does not prevent condensate drainage if the installation practices in this handbook are followed.

**IMPORTANT:** Be sure to read the discussion to the right, which deals with less common but important reductions in pressure differential.

**4. Maximum allowable pressure.** The trap must be able to withstand the maximum allowable pressure of the system or design pressure. It may not have to operate at this pressure, but it must be able to contain it. As an example, the maximum inlet pressure is 26 barg and the return line pressure is 11 barg. This results in a differential pressure of 15 bar; however, the trap must be able to withstand 26 barg maximum allowable pressure. See Fig. CG-23-1.

## Factors Affecting Pressure Differential

Except for failures of pressure control valves, differential pressure usually varies on the low side of the normal or design value. Variations in either the inlet or discharge pressure can cause this.

Inlet pressure can be reduced below its normal value by:

1. A modulating control valve or temperature regulator.
2. "Syphon drainage." Every 1 m of lift between the drainage point and the trap reduces the inlet pressure (and the differential) by 0,1 bar. See Fig. CG-23-2.

Discharge pressure can be increased above its normal value by:

1. Pipe friction.
2. Other traps discharging into a return system of limited capacity.
3. Elevating condensate. Every 1 m of lift increases the discharge pressure (and the differential) by 0,1 bar when the discharge is only condensate. However, with flash present, the extra back pressure could be reduced to zero. See Fig. CG-23-3, noting the external check valve.

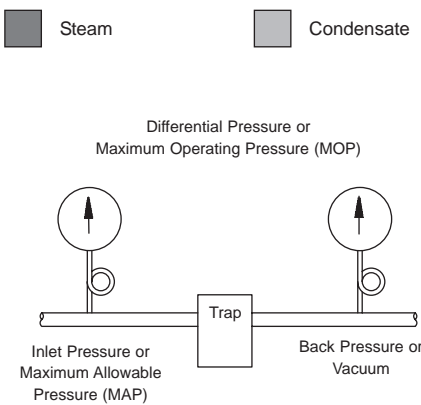

**Figure CG-23-1.** "A" minus "B" is Pressure Differential: If "B" is back pressure, subtract it from "A". If "B" is vacuum, add it to "A".

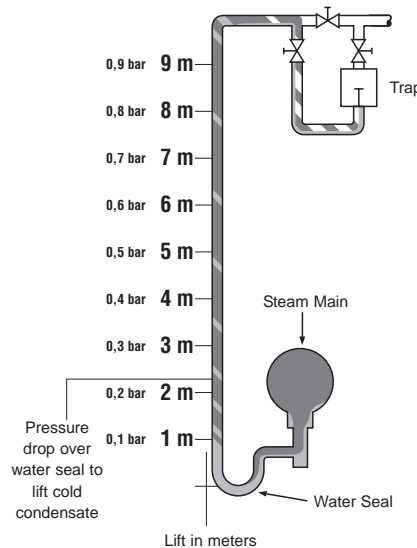

**Figure CG-23-2.** Condensate from gravity drain point is lifted to trap by a syphon. Every 1 m of lift reduces pressure differential by 0,1 bar. Note seal at low point and the trap's internal check valve to prevent backflow.

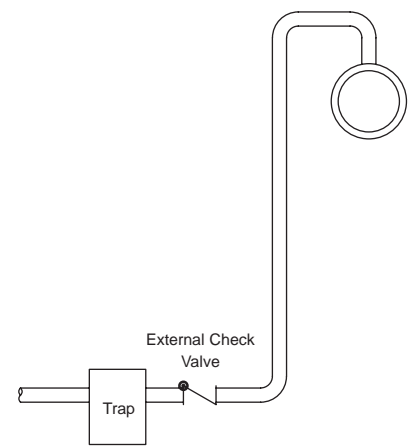

**Figure CG-23-3.** When trap valve opens, steam pressure will elevate condensate. Every 1 m of lift reduces pressure differential by 0,1 bar.





# How to Trap Steam Distribution Systems

Steam distribution systems link boilers and the equipment actually using steam, transporting it to any location in the plant where its heat energy is needed.

The three primary components of steam distribution systems are boiler headers, steam mains and branch lines. Each fulfills certain requirements of the system and, together with steam separators and steam traps, contributes to efficient steam use.

**Drip legs.** Common to all steam distribution systems is the need for drip legs at various intervals (Fig. CG-24-1). These are provided to:

1. Let condensate escape by gravity from the fast-moving steam.
2. Store the condensate until the pressure differential can discharge it through the steam trap.

**Figure CG-24-1. Drip Leg Sizing**

The properly sized drip leg will capture condensate. Too small a drip leg can actually cause a venturi "piccolo" effect where pressure drop pulls condensate out of the trap. For proper sizing, see Table CG-26-2 on page CG-26.

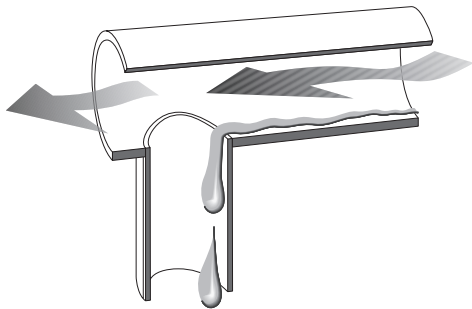

Table CG-24-1. Recommendation Chart (See Page CG-9 for "Feature Code" References.)		
Equipment Being Trapped	1st Choice and Feature Code	Alternate Choice
Boiler Header	IBLV M, E, L, N, B, Q	*F&T

\* On superheated steam never use an F&T type trap. Always use an IB with internal check valve and burnished valve and seat.

Equipment Being Trapped	1st Choice, Feature Code and Alternate Choice(s)	0 - 2 barg	Above 2 barg
Steam Mains and Branch Lines Non-freezing Conditions	B, M, N, L, F, E, C, D, Q	*IB	*IB
	Alternate Choice	F&T	**F&T
Steam Mains and Branch Lines Freezing Conditions	B, C, D, E, F, L, M, N, Q, J	*IB	*IB
	Alternate Choice	Thermostatic or CD	

\* Provide internal check valve when pressures fluctuate.

\*\* Use IBLV above F&T pressure/temperature limitations.

**NOTE:** On superheated steam, use an IB with internal check valve and burnished valve and seat.

## Boiler Headers

A boiler header is a specialized type of steam main that can receive steam from one or more boilers. It is most often a horizontal line which is fed from the top and in turn feeds the steam mains. It is important to trap the boiler header properly to assure that any carryover (boiler water and solids) is removed before distribution into the system.

Steam traps that serve the header must be capable of discharging large slugs of carryover as soon as they are present. Resistance to hydraulic shock is also a consideration in the selection of traps.

**Trap selection and safety factor for boiler headers (saturated steam only).** A 1.5:1 safety factor is recommended for virtually all boiler header applications. The required trap capacity can be obtained by using the following formula:

Required Trap Capacity = Safety Factor x Load Connected to Boiler(s) x Anticipated Carryover (typically 10%).

**EXAMPLE:** What size steam trap will be required on a connected load of 20 000 kg/h with an anticipated carryover of 10%? Using the formula:

Required Trap Capacity = 1,5 x 20 000 x 0,10 = 3 000 kg/h.

The ability to respond immediately to slugs of condensate, excellent resistance to hydraulic shock, dirt-handling ability and efficient operation on very light loads are features that make the inverted bucket the most suitable steam trap for this application.

**Installation.** If steam flow through the header is in one direction only, a single steam trap is sufficient at the downstream end. With a midpoint feed to the header (Fig. CG-24-2), or a similar two-directional steam flow arrangement, each end of the boiler header should be trapped.

**Figure CG-24-2. Boiler Headers**

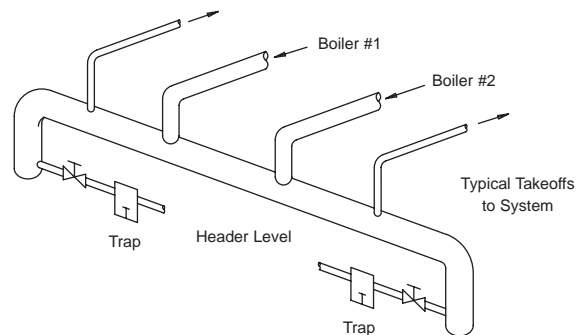

Drip leg same as the header diameter up to 100 mm. Above 100 mm, 1/2 header size, but never less than 100 mm.

# How to Trap Steam Distribution Systems



## Steam Mains

One of the most common uses of steam traps is the trapping of steam mains. These lines need to be kept free of air and condensate in order to keep steam-using equipment operating properly. Inadequate trapping on steam mains often leads to water hammer and slugs of condensate that can damage control valves and other equipment.

There are two methods used for the warm-up of steam mains – supervised and automatic. Supervised warm-up is widely used for initial heating of large-diameter and/or long mains. The suggested method is for drip valves to be opened wide for free blow to the atmosphere before steam is admitted to the main. These drip valves are not closed until all or most of the warm-up condensate has been discharged. Then the traps take over the job of removing condensate that may form under operating conditions. Warm-up of principal piping in a power plant will follow much the same procedure.

Automatic warm-up is when the boiler is fired, allowing the mains and some or all equipment to come up to pressure and temperature without manual help or supervision.

**CAUTION: Regardless of warm-up method, allow sufficient time during the warm-up cycle to minimize thermal stress and prevent any damage to the system.**

### Trap selection and safety factor for steam mains (saturated steam only)

Condensate loads on insulated or non-insulated pipe for either supervised or automatic warm-up methods can be calculated by using the following formula:

$$Q_c = \frac{(W_p \times T_1) \times c \times (t_1 - t_2)}{r \times h} \times 60$$

- $Q_c$  = Amount of condensate in kg/h
- $W_p$  = Weight of pipe in kg/m (see Table CG-25-2)
- $T_1$  = Total length of steam line in m
- $c$  = Specific heat of pipe material in kJ/kg/°C  
(steel pipe = 0,48 kJ/kg/°C)
- $t_2$  = Final temperature in °C
- $t_1$  = Initial temperature in °C
- $r$  = Latent heat in kJ/kg (see Steam Tables, column 5 on page CG-10)
- $h$  = Time in minutes for start-up

**NOTE:** for quick calculations  $t_1$  can be taken as 0°C and  $r$  can be fixed at 2 100 kJ/h.

For quickly determining the condensate load during the warming-up of a steam main, use Chart CG-25-1. Once the correct figure is found, multiply by a safety factor of 2 (the recommended safety factor for all traps located between the boiler and the end of the main line).

For condensing rate on normal operation (after warm-up), use Table CG-25-1.

**Table CG-25-1. Condensing Rates for Steam Pipes in kg/h/m<sup>2</sup>**

Steam Pressure (barg)	1	2	4	8	12	16	21
Pipe with Insulation	1	1	1,5	1,5	2	2,5	3
Pipe without Insulation	4	5	6	7	8	9	10

**Table CG-25-2. Pipe Characteristics for Radiation Loss Calculation**

Pipe Size		Outside Diameter	Outside Surface	Weight
Inches	DN	mm	m <sup>2</sup> /m	kg/m
1/8"	6	10,2	0,03	0,49
1/4"	8	13,5	0,04	0,77
3/8"	10	17,2	0,05	1,02
1/2"	15	21,3	0,07	1,45
3/4"	20	26,9	0,09	1,90
1"	25	33,7	0,11	2,97
1 1/4"	32	42,4	0,13	3,84
1 1/2"	40	48,3	0,15	4,43
2"	50	60,3	0,19	6,17
2 1/2"	65	76,1	0,24	7,90
3"	80	88,9	0,28	10,10
4"	100	114,3	0,36	14,40
5"	125	139,7	0,44	17,80
6"	150	165,1	0,52	21,20
8"	200	219,0	0,69	31,00
10"	250	273,0	0,86	41,60
12"	300	324,0	1,02	55,60
14"	350	355,0	1,12	68,30
16"	400	406,0	1,28	85,90
20"	500	508,0	1,60	135,00

**Chart CG-25-1. Amount of Condensate for 20 m of Pipe Heated From 0°C to Saturated Steam Temperature**

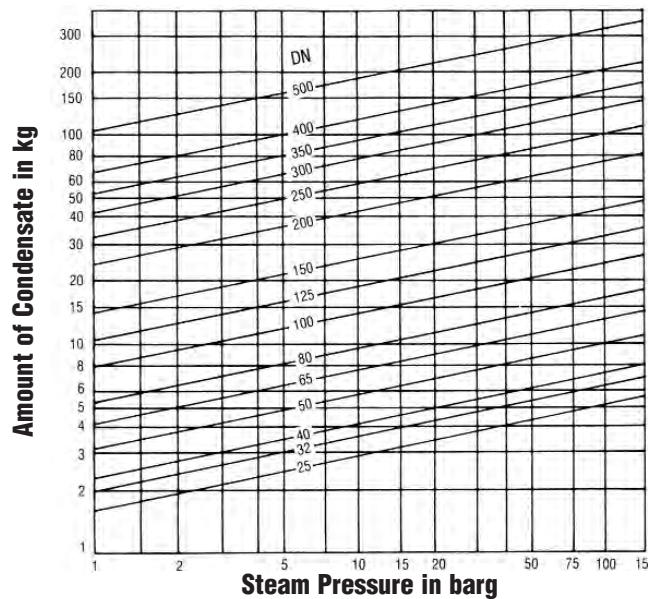



# How to Trap Steam Distribution Systems

For traps installed between the boiler and the end of the steam main, apply a 2:1 safety factor. Apply a 3:1 safety factor for traps installed at the end of the main or ahead of reducing and shutoff valves that are closed part of the time.

The inverted bucket trap is recommended because it can handle dirt and slugs of condensate and resists hydraulic shock. In addition, should an inverted bucket fail, it usually does so in the open position.

**Installation.** Both methods of warm-up use drip legs and traps at all low spots or natural drainage points such as:

- Ahead of risers
- End of mains
- Ahead of expansion joints or bends
- Ahead of valves or regulators

Install drip legs and drain traps even where there are no natural drainage points (See Figs. CG-26-1, CG-26-2 and CG-26-3). These should normally be installed at intervals of about 50 m and never longer than 75 m.

On a supervised warm-up, make drip leg length at least 1,5 times the diameter of the main, but never less than 250 mm. Make drip legs on automatic warm-ups a minimum of 700 mm in length. For both methods, it is a good practice to use a drip leg the same diameter as the main up to 100 mm pipe size and at least 1/2 of the diameter of the main above that, but never less than 100 mm. See Table CG-26-2.

## Steam Mains

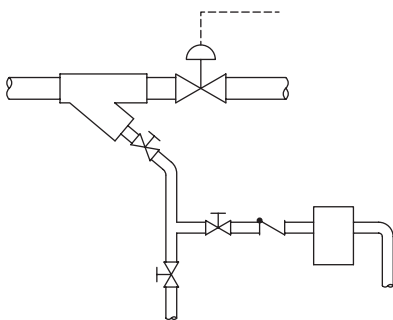

**Figure CG-26-1.**  
Trap draining strainer ahead of PRV.

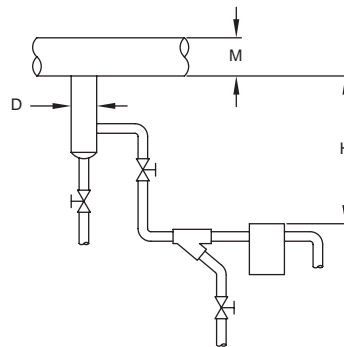

**Figure CG-26-2.**  
Trap draining drip leg on main.

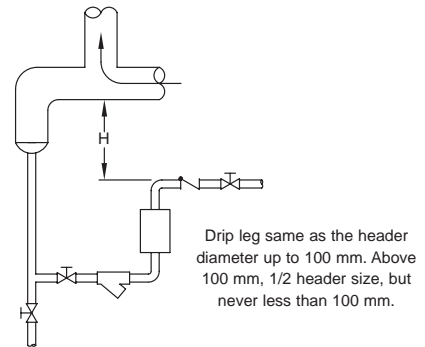

**Figure CG-26-3.**  
Trap draining drip leg at riser. Distance "H" in meters divided by 10 = static head pressure (bar) for forcing water through the trap.

Table CG-26-1. Recommendation Chart (See Page CG-9 for "Feature Code" References.)		
Equipment Being Trapped	1st Choice and Feature Code	Alternate Choice
Steam Separator	IBLV B, M, L, E, F, N, Q	DC

Table CG-26-2. Recommended Steam Main and Branch Line Drip Leg Sizing			
Steam Main Size (mm)	Drip Leg Diameter (mm)	Drip Leg Length Min. (mm)	
		Supervised Warm-Up (L)	
		Automatic Warm-Up (L)	
15	15	250	710
20	20	250	710
<b>25</b>	<b>25</b>	<b>250</b>	<b>710</b>
50	50	250	710
80	80	250	710
<b>100</b>	<b>100</b>	<b>250</b>	<b>710</b>
150	100	250	710
200	100	300	710
<b>250</b>	<b>150</b>	<b>380</b>	<b>710</b>
300	150	460	710
350	200	535	710
<b>400</b>	<b>200</b>	<b>610</b>	<b>710</b>
450	250	685	710
500	250	760	760
<b>600</b>	<b>300</b>	<b>915</b>	<b>915</b>

# How to Trap Steam Distribution Systems



## Branch Lines

Branch lines are take-offs from the steam mains supplying specific pieces of steam-using equipment. The entire system must be designed and hooked up to prevent accumulation of condensate at any point.

**Trap selection and safety factor for branch lines.** The formula for computing condensate load is the same as that used for steam mains. Branch lines also have a recommended safety factor of 3:1.

**Installation.** Recommended piping from the main to the control is shown in Fig. CG-27-1 for runouts under 3 m and Fig. CG-27-2 for runouts over 3 m. See Fig. CG-27-3 for piping when control valve must be below the main.

Install a full pipe-size strainer ahead of each control valve as well as ahead of the PRV, if used. Provide blowdown valves, preferably with IB traps. A few days after starting the system, examine the strainer screens to see if cleaning is necessary.

## Separators

Steam separators are designed to remove any condensate that forms within steam distribution systems. They are most often used ahead of equipment where especially dry steam is essential. They are also common on secondary steam lines, which by their very nature have a large percentage of entrained condensate.

Important factors in trap selection for separators are the ability to handle slugs of condensate, provide good resistance to hydraulic shock and operate on light loads.

**Trap selection and safety factors for separators.** Apply a 3:1 safety factor in all cases, even though different types of traps are recommended, depending on condensate and pressure levels.

Use the following formula to obtain the required trap capacity:

Required trap capacity in kg/h = safety factor x steam flow rate in kg/h x anticipated percent of condensate (typically 10%).

**EXAMPLE:** What size steam trap will be required on a flow rate of 500 kg/h? Using the formula:

Required trap capacity =  $3 \times 500 \times 0,10 = 150 \text{ kg/h}$ .

The inverted bucket trap with large vent is recommended for separators. When dirt and hydraulic shock are not significant problems, an F&T type trap is an acceptable alternative.

An automatic differential condensate controller may be preferred in many cases. It combines the best features of both of the above and is recommended for large condensate loads that exceed the separating capability of the separator.

## Installation

Connect traps to the separator drain line 250 mm to 300 mm below the separator with the drain pipe running the full size of the drain connection down to the trap take-off (Fig. CG-27-4). The drain pipe and dirt pocket should be the same size as the drain connection.

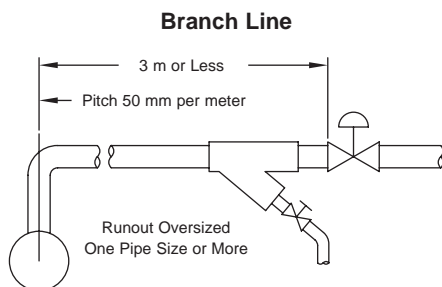

**Figure CG-27-1.** Piping for runout less than 3 m. No trap required unless pitch back to supply header is less than 50 mm per meter.

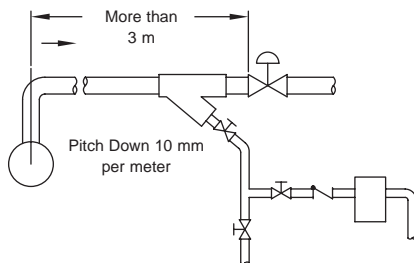

**Figure CG-27-2.** Piping for runout greater than 3 m. Drip leg and trap required ahead of control valve. Strainer ahead of control valve can serve as drip leg if blowdown connection runs to an inverted bucket trap. This will also minimize the strainer cleaning problem. Trap should be equipped with an internal check valve or a swing check installed ahead of the trap.

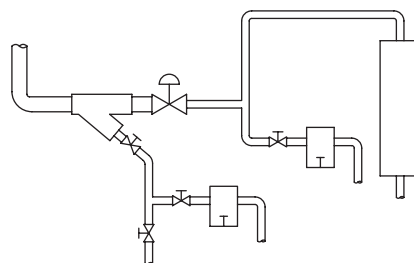

**Figure CG-27-3.** Regardless of the length of the runout, a drip leg and trap are required ahead of the control valve located below steam supply. If coil is above control valve, a trap should also be installed at downstream side of control valve.

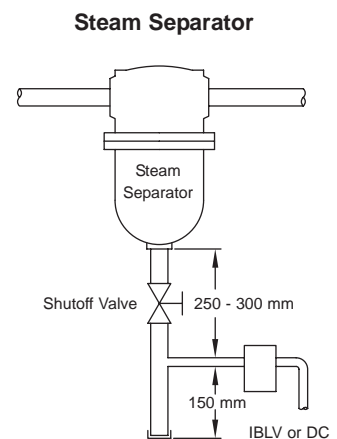

**Figure CG-27-4.** Drain downstream side of separator. Full-size drip leg and dirt pocket are required to ensure positive and fast flow of condensate to the trap.



# How to Trap Superheated Steam Lines

Steam Conservation Guidelines

At first glance, this may seem confusing due to the idea that superheated steam produces no condensate; therefore, the steam lines carrying superheated steam should not have any condensate in them. This is true once the system is up to temperature and pressure, but condensate removal is necessary up to this point. This section will explain what superheated steam is and the applications for its use.

The specific heat of any substance (using kJ standards) is the quantity of heat required to raise the temperature of 1 kg by 1°C. With this definition, the specific heat of water is 4,186 kJ, and the specific heat of superheated steam varies according to temperature and pressure. Specific heat decreases as the temperature rises but increases as the pressure goes up.

Superheated steam is customarily made by the addition of an extra set of coils inside the boiler or in the exhaust area of the boiler so as to use the “waste” heat from the boiler. Or, by the addition of a superheat chamber somewhere after the boiler, attached to the steam main. A schematic diagram of a steam generator with a superheated section of coil is shown below.

## Properties of Superheated Steam

Superheated steam has several properties that make it unsuitable as a heat energy exchange medium yet ideal for work and mass transfer. Unlike saturated steam, the pressure and temperature of superheated steam are independent. As superheat is formed at the same pressure as the saturated steam, the temperature and volume increase.

In high heat release boilers with relatively small drums, separation of steam from water is extremely difficult. The combination of the small volume of water in the drums and rapid load swings produces severe shrink and swell conditions in the drum, which promotes water carryover.

This water can be removed with separators and traps in the steam outlets, but they are not 100% efficient. In applications where dry steam is a necessity, additional superheating coils are placed in the boiler furnace as convection passes. More heat is added to the steam to vaporize the water carryover, which adds a small amount of superheat to guarantee absolutely dry steam.

Because superheated steam can give up so little heat before it converts back to saturated steam, it is not a good heat-transfer medium. Some processes, such as power plants, require a dry heat in order to do work. Whatever the type of power unit, superheat helps reduce the amount of condensation when starting from cold. Superheat also increases the power output by delaying condensation during the expansion stages in the equipment. Having drier steam at the exhaust end will increase the life of turbine blades.

Superheated steam can lose heat without condensing whereas saturated steam cannot. Therefore, superheated steam can be transported through very long steam lines without losing sufficient heat to condense. This permits the delivery of dry steam throughout the entire steam system.

## Why Trap Superheated Systems?

The primary reason for traps on superheat systems is the start-up load. It can be heavy because of the large size of the mains. On start-up, manual valves will most likely be used since time is available to open and to close the valves. This is known as supervised start-up. A second reason for steam traps is to handle emergencies such as superheater loss or by-pass, which might require operation on saturated steam. In these unscheduled events, there is no time available for manually opening valves; therefore, steam traps are a necessity.

These are the situations for which proper trap sizing is a must. Condensate must be removed as it forms in any steam system to keep efficiency high and to minimize damaging water hammer and erosion.

Figure CG-28-1. Steam Generator

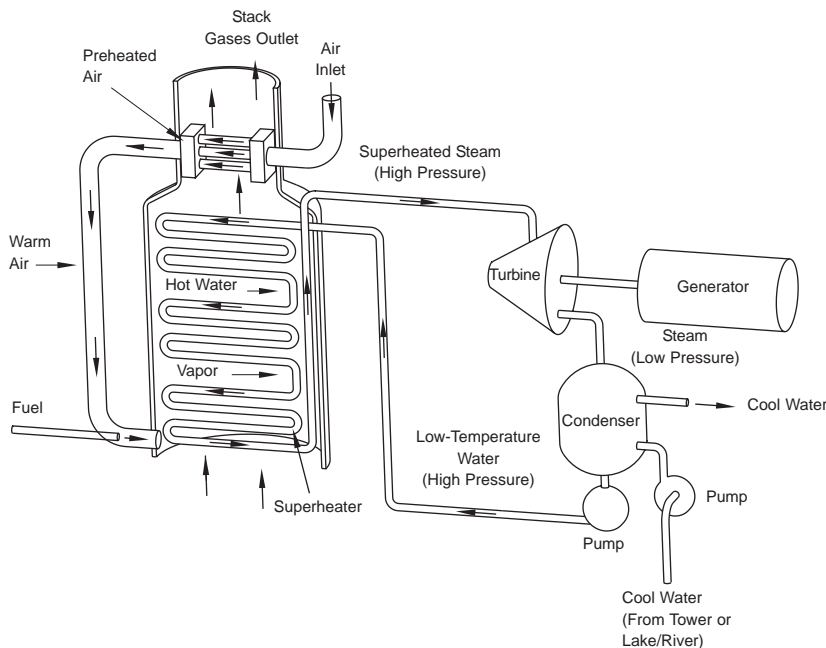

# How to Trap Superheated Steam Lines

## Sizing Superheat Loads to Traps

The condensate load to a trap used on superheat will vary widely from severe start-up loads to virtually no load during operation. Consequently, this is a demanding application for any steam trap.

During start-up, very large lines are being filled with steam from cold conditions. At this time, only saturated steam at low pressure is in the lines until the line temperature can be increased. This is done slowly over a long period so the lines are not stressed. Large condensate flow combined with low pressure is the start-up condition that requires the use of large capacity traps. These oversized traps are then required to operate at very high pressures with very low capacity requirements during normal superheat operation.

Typical start-up loads can be roughly calculated as follows:

### Using:

$$C = \frac{0,48 W_p (t_2 - t_1)}{H}$$

### Where:

C = Amount of condensate in kg  
 W<sub>p</sub> = Total weight of pipe (from Table CG-25-2 on page CG-25)  
 H = Total heat of X pressure minus Sensible heat of Y Pressure (Latent heat of steam. For long warm-up times, use the total heat of saturated steam at the superheat steam supply pressure (X) minus the sensible heat of saturated steam at the average pressure (Y) during the warm-up time involved.)

0,48 = Specific heat of steel pipe in kJ/kg/°C

### EXAMPLE:

Assuming a 50°C/h heat-up  
 14" diameter Schedule 80 line  
 Supply superheated steam at 83 bar, 577°C  
 Ambient temperature is 21°C  
 60 m of run between traps

#### For the first two hours:

W = 60 m x 68,3 kg/m = 4 098 kg  
 t<sub>2</sub> - t<sub>1</sub> = 121 - 21 = 100°C  
 H = 2 753 kJ/kg (83 barg) - 454 kJ/kg (0,35 barg) = 2 299 kJ

$$C = \frac{0,48 \text{ kJ/kg/°C} \times 4 098 \text{ kg} \times 100^\circ\text{C}}{2 299 \text{ kJ/kg}} = 85,6 \text{ kg}$$

#### For the second two hours:

The only thing that changes is the sensible heat (775 kJ/kg) of the saturated steam at average pressure during the time involved.

$$C = \frac{0,48 \text{ kJ/kg/°C} \times 4 098 \text{ kg} \times 100^\circ\text{C}}{1 978 \text{ kJ/kg}} = 99,4 \text{ kg}$$

**Table CG-29-1. Time Period Table**

Time Period	Average Pressure in barg	Temperature at End of Time Period in °C	14" Line Condensation Rate in kg/h
1 <sup>st</sup> 2 hours	0,35	121	42,9
2 <sup>nd</sup> 2 hours	9,7	221	49,7
3 <sup>rd</sup> 2 hours	48	321	61,5
4 <sup>th</sup> 2 hours	83	721	58,3
5 <sup>th</sup> 2 hours	83	577	76,2

**NOTE:** For the average pressure of 83 barg, assume H to be the latent heat of 83 barg steam plus superheat at temperature at the end of the period.

To ensure the condensate is removed efficiently, proper drip leg sizing and piping recommendations should also be followed when installing traps on superheat systems. The Table CG-26-2 on page CG-26 lists the proper drip leg size for given pipe sizes.

The question arises whether insulation should be used on the drip leg, piping leading to the trap, and the trap. The answer is no; unless it is mandatory for safety reasons, this section of the steam system should not be insulated. This ensures that some condensate is continuously being formed ahead of the trap and going to it, thus prolonging the trap's life.

## Types of Superheat Traps

### Bimetallic

A bimetallic trap is set to not open until condensate has cooled to a temperature below saturation. For the existing pressure, it will remain closed whenever steam of any temperature is in the trap. As the steam temperature rises, the pull of the bimetallic element becomes greater, providing a greater sealing force on the valve. Superheated steam tends to seal the valve better. The bimetallic trap also has the ability to handle large start-up loads. For these reasons, this trap is a good choice for superheat.

During superheat operation, the condensate in the trap must cool to a temperature below the saturation temperature before the trap can open. Condensate may back up into the line and cause damage to the lines, valves and equipment if drip leg size and length before the trap are insufficient.

### Inverted Bucket

A water seal prevents steam from getting to the valve, promoting no live steam loss and long life. The valve at the top makes it impervious to dirt and permits removal of air. Large start-up loads can be handled, and the trap can still accommodate small running loads. There are problems associated with its application on superheat, mostly associated with the necessity of maintaining its water seal or "prime." Proper piping is necessary to maintain a prime in the IB.

For proper inverted bucket piping on superheat, refer to Figure CG-26-3 on page CG-26. When sizing a superheat trap, size for start-up load with no safety factor. Body materials should be selected on the basis of maximum pressure and temperature, including superheat.



# How to Trap Steam Tracer Lines

Steam tracer lines are designed to maintain the fluid in a primary pipe at a certain uniform temperature. In most cases, these tracer lines are used outdoors, which makes ambient weather conditions a critical consideration.

The primary purpose of steam traps on tracer lines is to retain the steam until its latent heat is fully utilized and then discharge the condensate and non-condensable gases. As is true with any piece of heat transfer equipment, each tracer line should have its own trap. Even though multiple tracer lines may be installed on the same primary fluid line, unit trapping is required to prevent short circuiting. See page CG-22.

In selecting and sizing steam traps, it's important to consider their compatibility with the objectives of the system, as traps must:

1. Conserve energy by operating reliably over a long period of time.
2. Provide abrupt periodic discharge in order to purge the condensate and air from the line.
3. Operate under light load conditions.
4. Resist damage from freezing if the steam is shut off.

The cost of steam makes wasteful tracer lines an exorbitant overhead no industry can afford.

### Trap Selection for Steam Tracer Lines.

The condensate load to be handled on a steam tracer line can be determined from the heat loss from the product pipe by using this formula:

$$Q_c = \frac{k \times L \times S}{r}$$

#### Where:

- $Q_c$  = Condensate load, kg/h
- $k$  = Heat losses from insulated pipe in kg/h/m<sup>2</sup> (see Table CG-25-1, page CG-25)
- $L$  = Length of main pipe in meters
- $S$  = Outside surface of pipe in m<sup>2</sup>/m (see Table CG-25-2, page CG-25)
- $r$  = Latent heat in kJ/kg (see Steam Tables, column 5 on page CG-10)

Figure CG-30-1. Typical Tracer Installation

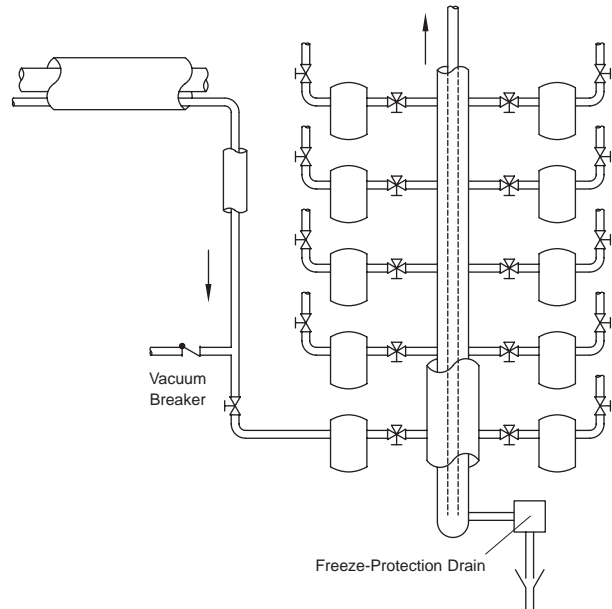

Table CG-30-1. Recommendation Chart (See Page CG-9 for "Feature Code" References.)		
Equipment Being Trapped	1st Choice and Feature Code	Alternate Choice
Tracer Lines	*IB A, B, C, L, J, N, I, K	Thermostatic or CD

Typical Tracer Installation

Figure CG-30-2

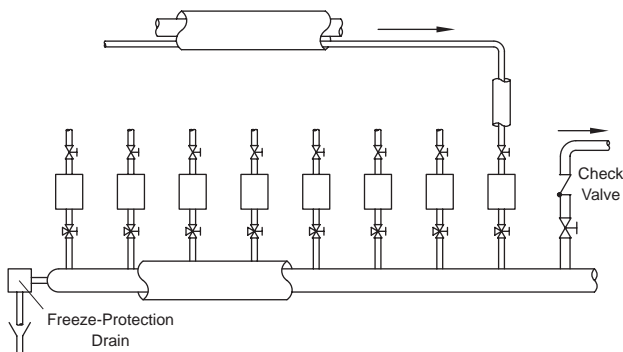
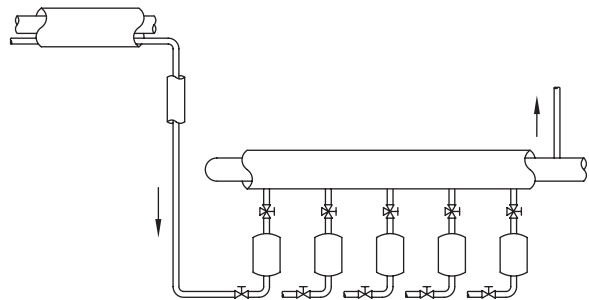

Figure CG-30-3



# How to Trap Steam Tracer Lines

**EXAMPLE:** Three tracer lines at 11 barg steam pressure are used on a 100 mm diameter, 30 m long insulated pipe to maintain a temperature of 100°C with an outdoor design temperature of -25°C. For such conditions, the recommended pipe insulation thickness is 100 mm (see Tables CG-31-2 and CG-31-3). What is the condensate load?

Using the formula:

$$Q_c = \frac{45,7 \text{ W/m} \times 3,6 \text{ kJ/h/W} \times 30 \text{ m}}{1 \text{ 983 kJ/kg}} = 2,5 \text{ kg/h}$$

Now divide by three in order to get the load per tracer line – 0,84 kg/h.

On most tracer line applications, the flow to the steam trap is surprisingly low; therefore, the smallest trap is normally adequate. Based on its ability to conserve energy by operating reliably over a long period of time, handle light loads, resist freezing and purge the system, an inverted bucket trap is recommended for tracer line service.

**Safety factor.** Use a 2:1 safety factor whether exposure to ambient weather conditions is involved or not. Do not oversize steam traps or tracer lines.

## Installation

Install distribution or supply lines at a height above the product lines requiring steam tracing. For the efficient drainage of condensate and purging of non-condensables, pitch tracer lines for gravity drainage and trap all low spots. This will also help avoid tracer line freezing. (See Figs. CG-30-1, CG-30-2 and CG-30-3).

To conserve energy, return condensate to the boiler. Use vacuum breakers immediately ahead of the traps to ensure drainage on shutdown on gravity drain systems. Freeze-protection drains on trap discharge headers are suggested where freezing conditions prevail.

**Table CG-31-1. Heat Losses in W/m from Insulated Pipes**

Pipe Diameter	Insulation Thickness	Product / Ambient Temperature Difference in °C					
		25	50	75	100	125	150
DN50	40	10,9	21,8	32,7	43,6	54,5	65,4
	60	8,5	16,9	25,4	33,8	42,3	50,7
	80	7,2	14,3	21,5	28,7	35,8	43,0
DN80	60	10,8	21,6	32,3	43,1	53,9	64,7
	80	9,0	18,0	26,9	35,9	44,9	53,9
	100	7,9	15,7	23,6	31,5	39,3	47,2
DN100	60	12,8	25,6	38,3	51,1	63,9	76,7
	80	10,5	21,1	31,6	42,1	52,6	63,2
	100	9,1	18,3	27,4	36,5	45,7	54,8
	120	8,2	16,4	24,6	32,7	40,9	49,1
DN150	60	16,9	33,8	50,6	67,5	84,4	101,3
	80	13,7	27,4	41,1	54,8	68,5	82,2
	100	11,7	23,5	35,2	46,9	58,7	70,4
	120	10,4	20,8	31,2	41,6	52,0	62,4
DN200	80	16,6	33,2	49,8	66,3	82,9	99,5
	100	14,1	28,2	42,3	56,4	70,5	84,6
	120	12,4	24,8	37,2	49,6	62,0	74,4
	140	11,2	22,4	33,5	44,7	55,9	67,1
DN250	80	19,6	39,2	58,7	78,3	97,9	117,5
	100	16,5	33,1	49,6	66,2	82,7	99,3
	140	13,0	26,0	39,0	51,9	64,9	77,9
DN300	80	22,4	44,7	67,1	89,5	111,8	134,2
	100	18,8	37,6	56,5	75,3	94,1	112,9
	120	16,4	32,8	49,2	65,6	82,0	98,4
	140	14,7	29,3	44,0	58,6	73,3	87,9
	160	13,3	26,7	40,0	53,3	66,6	80,0
DN350	80	24,1	48,1	72,2	96,3	120,4	144,4
	100	20,2	40,4	60,6	80,9	101,1	121,3
	120	17,6	35,2	52,8	70,4	88,0	105,5
	140	15,7	31,4	47,1	62,8	78,4	94,1
	160	14,2	28,5	42,7	57,0	71,2	85,4
DN400	100	22,4	44,9	67,3	89,7	112,1	134,6
	120	19,5	38,9	58,4	77,9	97,3	116,8
	140	17,3	34,6	52,0	69,3	86,6	103,9
	160	15,7	31,4	47,1	62,8	78,4	94,1

**Table CG-31-2. Recommended Insulation in mm for Pipes at 3,5 barg**

Product Line Diameter	Product Temperature in °C							
	10	20	30	40	50	60	70	80
DN25	40	40	40	40	40	40	40	40
DN40	40	40	40	40	40	40	60	60
DN50	40	40	40	40	60	60	60	60
DN80	40	40	60	60	60	60	60	80
DN100	40	60	60	60	60	80	80	80
DN150	40	60	60	80	80	80	100	100
DN200	60	60	80	80	80	100	100	120
DN250	60	80	80	80	100	100	120	120
DN300	80	80	80	100	100	120	120	120
DN350	80	80	80	100	120	120	120	140
DN400	80	80	100	120	120	120	140	140
DN500	80	80	100	120	120	140	140	160
DN600	80	100	120	120	140	140	160	160

**Table CG-31-3. Recommended Insulation in mm for Pipes at 10 barg**

Product Line Diameter	Product Temperature in °C								
	50	60	70	80	90	100	110	120	130
DN25	40	40	40	40	60	60	60	60	60
DN40	40	40	60	60	60	60	60	80	80
DN50	60	60	60	60	60	60	80	80	80
DN80	60	60	60	80	80	80	80	100	100
DN100	60	80	80	80	80	100	100	100	120
DN150	80	80	100	100	100	120	120	120	120
DN200	80	100	100	120	120	120	120	140	140
DN250	100	100	120	120	120	140	140	140	140
DN300	100	120	120	120	140	140	140	140	160
DN350	120	120	120	140	140	140	160	160	160
DN400	120	120	140	140	160	160	160	160	160
DN500	120	140	140	160	160	160	160	180	180
DN600	140	140	160	160	160	180	180	180	180





# How to Trap Space Heating Equipment

Steam Conservation Guidelines

Space heating equipment such as unit heaters, air handling units, finned radiation and pipe coils is found in virtually all industries. This type of equipment is quite basic and should require very little routine maintenance. Consequently, the steam traps are usually neglected for long periods of time. One of the problems resulting from such neglect is residual condensate in the heating coil, which can cause damage due to freezing, corrosion and water hammer.

## Trap Selection and Safety Factors

Different application requirements involving constant or variable steam pressure determine which type and size of trap should be used. There are two standard methods for sizing traps for coils.

### 1. Constant Steam Pressure.

INVERTED BUCKET TRAPS AND F&T TRAPS – Use a 3:1 safety factor at operating pressure differentials.

### 2. Modulating Steam Pressure.

F&T TRAPS AND INVERTED BUCKET TRAPS WITH THERMIC BUCKETS

- 0 - 1 barg steam – 2:1 safety factor at 0,1 bar pressure differential
- 1 - 2 barg steam – 2:1 at 0,2 bar pressure differential
- Above 2 barg steam – 3:1 at 1/2 of maximum pressure differential across the trap.

INVERTED BUCKET TRAPS WITHOUT THERMIC BUCKETS

Above 2 barg steam pressure only – 3:1 at 1/2 of maximum pressure differential across the trap.

## Trap Selection for Unit Heaters and Air Handling Units

You may use three methods to compute the amount of condensate to be handled. Known operating conditions will determine which method to use.

1. **kJ method.** The standard rating for unit heaters and other air coils is kJ output with 0,15 barg steam pressure in the heater and entering air temperature of 15°C. To convert from standard to actual rating, use the conversion factors in Table CG-34-1 (page CG-34). Once the actual operating conditions are known, multiply the condensate load by the proper safety factor.

2. **m<sup>3</sup>/min and air temperature rise method.** If you know only m<sup>3</sup>/min capacity of fan and air temperature rise, find the actual kJ output by using this simple formula:

$$\text{kJ/h} = \text{m}^3/\text{min} \times 75 \times \text{temperature rise in } ^\circ\text{C}.$$

**EXAMPLE:** What size trap will drain a 100 m<sup>3</sup>/min heater that produces an 30°C temperature rise? Steam pressure is constant at 5 barg.

Using the formula:

$$100 \times 75 \times 30 = 225\,000 \text{ kJ/h.}$$

Now divide 225 000 kJ/h by 2 084 kJ/h (from the Steam Tables) to obtain 108 kg/h of condensate and then multiply by the recommended safety factor 3. The application needs a trap with a 324 kg/h capacity.

Derive the 75 factor in the above formula as follows:

$$1 \text{ m}^3/\text{min} \times 60 = 60 \text{ m}^3/\text{min}$$

$$60 \text{ m}^3/\text{min} \times 1,25 \text{ kg/h (the specific gravity of air at } 5^\circ\text{C)} = 75 \text{ kg/h of air}$$

$$75 \text{ kg/h} \times 1 \text{ kJ/kg}^\circ\text{C (specific heat of air)} = 75 \text{ kJ/h}^\circ\text{C}.$$

3. **Condensate method.** Once you determine kJ output:

- a. Divide kJ output by latent heat of steam at steam pressure used. See Column 2 of Table CG-34-1 or the Steam Tables (page CG-10). This will give the actual weight of steam condensed. For a close approximation, a rule of thumb could be applied in which the kJ output is simply divided by 2 100.
- b. Multiply the actual weight of steam condensing by the safety factor to get the continuous trap discharge capacity required.

Chart CG-32-1. Multipliers for Sizing Traps for Multiple Coils

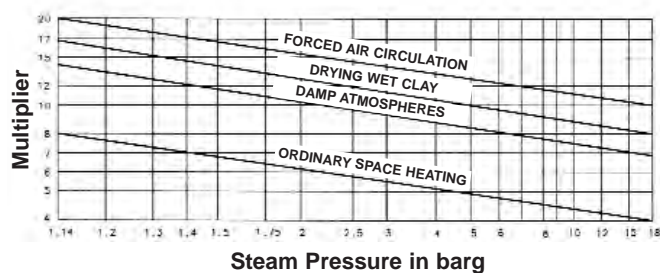

Table CG-32-1. Recommendation Chart

(See Page CG-9 for "Feature Code" References.)

Equipment Being Trapped	1st Choice and Feature Code	Constant Pressure		1st Choice and Feature Code	Variable Pressure	
		0 - 2 barg	Above 2 barg		0 - 2 barg	Above 2 barg
Unit Heaters	B, C, E, K, N	IBLV	IBLV	B, C, G, H, L	F&T	*F&T
	Alternate Choice	F&T	*F&T	Alternate Choice	IBLV	IBLV
Air Handling Units	B, C, E, K, N, O	IBLV	IBLV	B, C, G, H, L	F&T	*F&T
	Alternate Choice	F&T	*F&T	Alternate Choice	IBLV	IBLV
Finned Radiation & Pipe Coils	B, C, E, K, N	IBLV	IBLV	B, C, G, H, L	F&T	F&T
	Alternate Choice	Thermostatic	Thermostatic	Alternate Choice	IBLV	IBLV

\* Use IBLV above F&T pressure/temperature limitations.

**PLEASE NOTE:**

1. Provide vacuum breaker wherever subatmospheric pressures occur.
2. Do not use F&T traps on superheated steam.

# How to Trap Space Heating Equipment

## Trap Selection for Pipe Coils and Finned Radiation

**Pipe coils.** Insofar as possible, trap each pipe individually to avoid short circuiting.

**Single pipe coils.** To size traps for single pipes or individually trapped pipes, find the condensing rate per meter of pipe in Table CG-34-2 (page CG-34). Multiply the condensing rate per meter by the length in meters to get the normal condensate load.

For quick heating, apply a trap selection safety factor of 3:1 and use an inverted bucket trap with a thermic vent bucket. Where quick heating is not required, use a trap selection safety factor of 2:1 and select a standard inverted bucket trap.

**Multiple pipe coils.** To size traps to drain coils consisting of multiple pipes, proceed as follows:

1. Multiply the length in meters of pipe in the coil by the condensing rate given in Table CG-34-2. This gives the normal condensate load in kg/h.
2. From Chart CG-32-1 (page CG-32), find the multiplier for your service conditions.
3. Multiply normal condensate load by multiplier to get trap required continuous discharge capacity. **Note that the safety factor is included in the multiplier.**

**Finned radiation.** When kJ output is not known, condensing rates can be computed from Tables CG-34-3 and CG-34-4 (page CG-34) with sufficient accuracy for trap selection purposes. To enter Table CG-34-3, observe size of pipe, size of fins, number of fins and material. Determine condensing rate per meter under standard conditions from Table CG-34-3.

**Figure CG-33-1. Trapping and Venting Air Heat Coil**

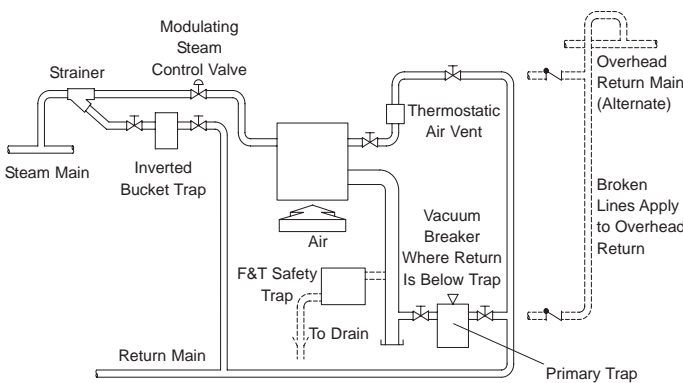

**Figure CG-33-2. Trapping and Venting Air Heat Coil**

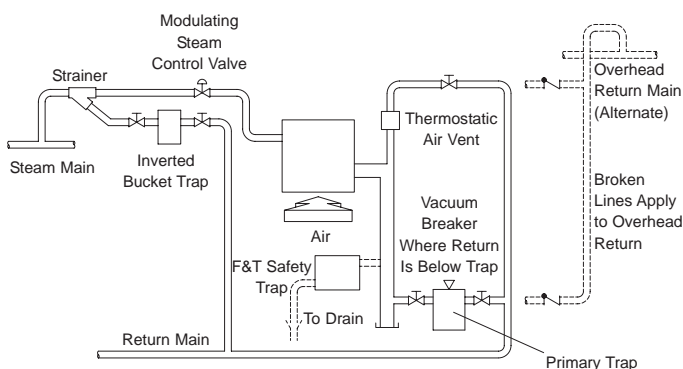

Convert to actual conditions with Table CG-34-4.

**Safety factor** recommendations are to:

1. Overcome the short circuiting hazard created by the multiple tubes of the heater.
2. Ensure adequate trap capacity under severe operating conditions. In extremely cold weather the entering air temperature is likely to be lower than calculated, and the increased demand for steam in all parts of the plant may result in lower steam pressures and higher return line pressures – all of which cut trap capacity.
3. Ensure the removal of air and other non-condensables.

**WARNING:** For low-pressure heating, use a safety factor at the actual pressure differential, not necessarily the steam supply pressure, remembering that the trap must also be able to function at the maximum pressure differential it will experience.

## Installation

In general, follow the recommendations of the specific manufacturer. Figs. CG-33-1, CG-33-2, CG-33-3 and CG-33-4 represent the consensus of space heating manufacturers.

**NOTE:** For explanation of safety drain trap, see Fig. CG-54-1 (page CG-54).

**Figure CG-33-3. Generally approved method of piping and trapping high-pressure (above 1 barg) horizontal discharge heaters. Figs. CG-33-3 and CG-33-4 drip leg should be 250 - 300 mm minimum.**

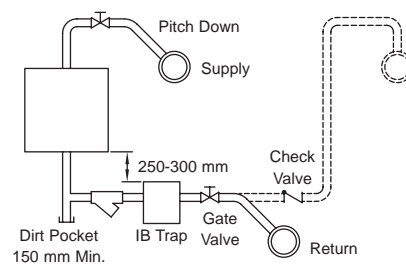

**Figure CG-33-4. Generally approved method of piping and trapping low-pressure (under 1 barg) vertical discharge heaters.**

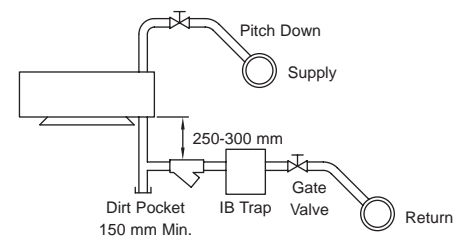



# How to Trap Space Heating Equipment

**Table CG-34-1. A Table of Constants** for determining the kJ output of a unit heater with conditions other than standard - standard being with 1,15 barg steam pressure at 15°C entering air temperature. To apply, multiply the standard kJ capacity rating of heater by the indicated constant. (Reprinted from ASHRAE Guide by special permission.)

Steam Pressure in barg	Latent Heat of Steam in kJ/kg	Entering Air Temperature °C						
		-24	-12	0	+10	+15	+20	+32
0,15	2 248	-	-	-	1,07	1,00	0,92	0,78
0,35	2 238	1,64	1,45	1,28	1,12	1,05	0,97	0,82
0,7	2 214	1,73	1,54	1,37	1,21	1,31	1,05	0,90
1,0	2 201	1,79	1,61	1,44	1,27	1,19	1,11	0,97
1,5	2 181	1,86	1,67	1,49	1,33	1,25	1,17	1,02
2,0	2 163	1,96	1,77	1,59	1,42	1,33	1,26	1,11
3,5	2 119	2,13	1,93	1,75	1,58	1,49	1,41	1,26
5,0	2 084	2,25	2,05	1,87	1,69	1,61	1,52	1,36
5,5	2 075	2,31	2,11	1,92	1,74	1,66	1,57	1,41
7,0	2 046	2,40	2,20	2,01	1,83	1,74	1,66	1,50

**Table CG-34-2. Condensing Rates in Bare Pipe Carrying Saturated Steam**

Pipe Size (mm)	m <sup>2</sup> per meter of Pipe	Steam Pressure (barg), Temperature Rise from 21°C					
		1 barg 120°C	2 barg 133°C	4 barg 152°C	8,5 barg 177°C	12 barg 192°C	17 barg 207°C
15	0,07	0,19	0,22	0,28	0,39	0,45	0,52
20	0,09	0,22	0,28	0,36	0,49	0,57	0,67
25	0,11	0,28	0,34	0,42	0,58	0,68	0,80
32	0,13	0,34	0,42	0,54	0,73	0,85	1,00
40	0,15	0,39	0,48	0,61	0,82	0,97	1,13
50	0,19	0,49	0,60	0,74	1,01	1,19	1,38
65	0,24	0,58	0,70	0,88	1,21	1,41	1,65
80	0,28	0,68	0,83	1,04	1,43	1,68	1,95
100	0,36	0,86	1,04	1,33	1,80	2,13	2,56

**Table CG-34-3. Finned Radiation Condensing Rates with 18°C air and 102°C steam (for trap selection purposes only)**

	Pipe Size (mm)	Fin Size (mm)	Fins per Inch	Number of Pipes High on 150 mm Centers	Condensate in kg/h per meter of pipe
Steel Pipe, Steel Fins Painted Black	32	82,6	3 to 4	1	1,64
				2	2,98
				3	3,87
	32	108	3 to 4	1	2,38
				2	3,57
				3	4,62
50	108	2 to 3	1	2,23	
			2	3,57	
			3	4,62	
Copper Pipe, Aluminium Fins Unpainted	32	82,6	4	1	2,38
				2	3,28
				3	4,17
	32	108	5	1	3,28
				2	4,47
				3	5,36

**Table CG-34-4. Finned Radiation Conversion Factors for Temperatures other than 18°C air and 102°C Steam**

Steam Pressure (barg)	Steam Temp. (°C)	Entering Air Temperature (°C)						
		7	13	18	21	24	27	32
0,05	101,7	1,22	1,11	1,00	0,95	0,90	0,84	0,75
0,35	108,4	1,34	1,22	1,11	1,05	1,00	0,95	0,81
0,70	115,2	1,45	1,33	1,22	1,17	1,11	1,05	0,91
1,00	120,2	1,55	1,43	1,31	1,26	1,20	1,14	1,00
2,00	133,5	1,78	1,66	1,54	1,48	1,42	1,37	1,21
4,00	151,8	2,10	2,00	1,87	1,81	1,75	1,69	1,51
7,00	170,4	2,43	2,31	2,18	2,11	2,05	2,00	1,81
8,50	177,7	2,59	2,47	2,33	2,27	2,21	2,16	1,96
12,00	191,6	2,86	2,74	2,60	2,54	2,47	2,41	2,21

# How To Trap Process Air Heaters

Process air heaters are used for drying paper, lumber, milk, starch and other products as well as preheating combustion air for boilers.

Common examples of this type of equipment are process dryers, tunnel dryers, and combustion air preheaters. Compared with air heaters for space heating, process air heaters operate at very high temperature, 260°C not being uncommon. These extremely high-temperature applications require high pressure (and occasionally superheated) steam.

## Trap Selection and Safety Factor

Determine the condensate load for process air heaters with the following formula:

$$Q_c = \frac{V \times c \times r \times 60 \text{ min/h} \times \Delta t}{r}$$

### Where:

- $Q_c$  = Condensate load in kg/h
- $V$  = Cubic meters of air per minute
- $c$  = Specific heat of air in kJ/kg/°C (from Table CG-60-2, page CG-60)
- $r$  = Density of air – 1,2 kg/m<sup>3</sup> at 15°C (air supply temperature)
- $\Delta t$  = Temperature rise in °C
- $r$  = Latent heat of steam in kJ/kg (see Steam Tables, column 5 on page CG-10)

**EXAMPLE:** What would be the condensate load on a tunnel dryer coil handling 60 m<sup>3</sup>/min of air and requiring a 35°C temperature rise? The steam pressure is 5 barg. Using the formula:

$$Q = \frac{60 \times 1 \times 1,2 \times 60 \times 35}{2084}$$

$$Q = 72,5 \text{ kg/h}$$

Multiplying by a safety factor of 2 – which is recommended for all constant pressure process air heaters – indicates that a trap with a capacity of 145 kg/h will be required. This is based on one coil. For higher air temperature rises, additional coils in series may be required.

## Safety Factors

For constant steam pressure, use a safety factor of 2:1 at operating pressure differential. For modulating steam pressure, use a safety factor of 3:1 at 1/2 of maximum pressure differential across the trap.

## Installation

Give piping for an entire piece of process air heating equipment – including all steam trap connections – adequate allowance for expansion due to the wide temperature variations. Mount traps 250 - 300 mm below the coils with a dirt pocket of at least 150 mm. On both constant and modulated pressure heaters, install a vacuum breaker between the coil and the steam trap. Install an air vent on each coil to remove air and other non-condensables that can cause rapid corrosion. See Figure CG-35-1.

**Consider a safety drain if condensate is elevated after the trap or if back pressure is present. See page CG-54 for piping diagram and explanation.**

**Figure CG-35-1. Process Air Heater**

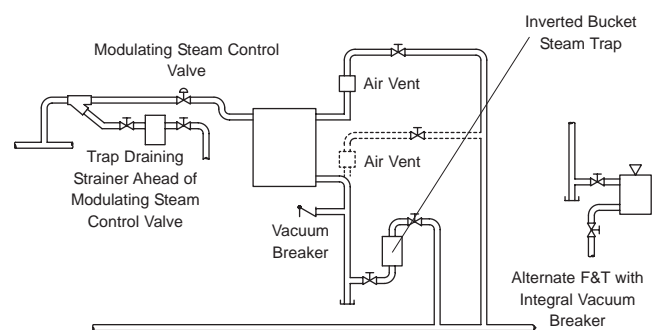

**Table CG-35-1. Recommendation Chart**  
(See Page CG-9 for "Feature Code" References.)

Equipment Being Trapped	1st Choice and Feature Code	Constant Pressure		1st Choice and Feature Code	Variable Pressure	
		0 - 2 barg	Above 2 barg		0 - 2 barg	Above 2 barg
Process Air Heaters	A, B, F, I, K, M	IB	IB	B, C, G, H, L	F&T	*F&T
	Alternate Choice	F&T	IBLV	Alternate Choice	IBLV	IBLV

\* Use IBLV above F&T pressure/temperature limitations.

### PLEASE NOTE:

1. Provide vacuum breaker wherever subatmospheric pressures occur.
2. Do not use F&T traps on superheated steam.



# How to Trap Shell & Tube Heat Exchangers & Submerged Coils

Steam Conservation Guidelines

Submerged coils are heat transfer elements that are immersed in the liquid to be heated, evaporated or concentrated. This type of coil is found in virtually every plant or institution that uses steam. Common examples are water heaters, reboilers, suction heaters, evaporators and vaporizers. These are used in heating water for process or domestic use, vaporizing industrial gases such as propane and oxygen, concentrating in-process fluids such as sugar, black liquor and petroleum, and heating fuel oil for easy transfer and atomization.

Different application requirements involving constant or variable steam pressure determine which type of trap should be used. Trap selection factors include the ability to handle air at low differential pressures, energy conservation and the removal of dirt and slugs of condensate. Three standard methods of sizing help determine the proper type and size traps for coils.

## Safety Factor

- 1. Constant Steam Pressure. INVERTED BUCKET TRAPS OR F&T TRAPS** – use a 2:1 safety factor at operating pressure differentials.
- 2. Modulating Steam Pressure. F&T TRAPS OR INVERTED BUCKET TRAPS.**
  - 1 - 1 barg steam – 2:1 at 0,1 bar pressure differential.
  - 1 - 2 barg steam – 2:1 at 0,2 bar pressure differential.
  - Above 2 barg steam – 3:1 at 1/2 of maximum pressure differential across the trap.
- 3. Constant or Modulating Steam Pressure with Syphon Drainage.** An automatic differential condensate controller with a safety factor of 3:1 should be used. An alternate is an IBLV with a 5:1 safety factor.

Apply the safety factor at full differential on constant steam pressure. Apply the safety factor at 1/2 maximum differential for modulating steam pressure.

## Shell and Tube Heat Exchangers

One type of submerged coil is the shell and tube heat exchanger (Fig. CG-36-1). In these exchangers, numerous tubes are installed in a housing or shell with confined free area. This ensures positive contact with the tubes by any fluid flowing in the shell. Although the term submerged coil implies that steam is in the tubes and the tubes are submerged in the liquid being heated, the reverse can also be true, where steam is in the shell and a liquid is in the tubes.

## Trap Selection for Shell and Tube Heat Exchangers

To determine the condensate load on shell and tube heaters, use the following formula when actual rating is known.\* (If heating coil dimensions alone are known, use formula shown for embossed coils. Be sure to select applicable “k” factor):

$$Q_c = \frac{m \times \Delta t \times c \times 60 \times \text{s.g.}}{r}$$

### Where:

- $Q_c$  = Condensate load in kg/h
- $m$  = Liquid flow in l/min
- $\Delta t$  = Temperature rise in °C
- $c$  = Specific heat of liquid in kJ/kg/°C (Table CG-60-1, page CG-60)
- 60 = 60 min/h
- s.g. = Specific gravity of liquid (Table CG-60-1, page CG-60)
- $r$  = Latent heat of steam in kJ/kg (see Steam Tables, column 5 on page CG-10)

**EXAMPLE:** Assume a water flow rate of 30 l/min with an entering temperature of 20°C and a leaving temperature of 120°C. Steam pressure is 1 barg. Determine the condensate load.

Using the formula:

$$Q_c = \frac{30 \text{ l/min} \times 100^\circ\text{C} \times 4,18 \text{ kJ/kg/}^\circ\text{C} \times 60 \times 1}{2257 \text{ kJ/kg}} = 333 \text{ kg/h}$$

\* Size steam traps for reboilers, vaporizers and evaporators (processes that create vapor) using the formula for **EMBOSSED COILS** on page CG-37.

**Figure CG-36-1. Shell And Tube Heat Exchangers**  
(Typical Piping Diagram)

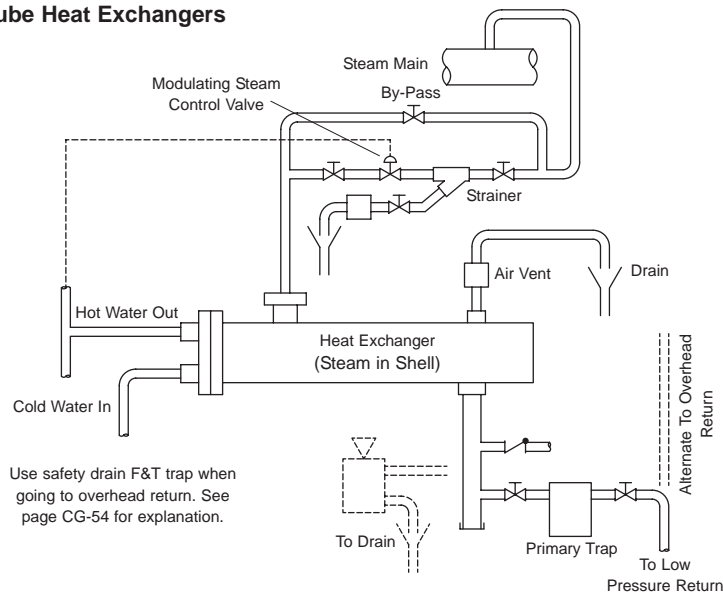

# How to Trap Shell & Tube Heat Exchangers & Submerged Coils



**Rule of Thumb for Computing Condensing Rate for Water Heaters:** Raising the temperature of 500 liters of water by 1°C will condense one kilogram of steam.

## Embossed Coils

Very often open tanks of water or chemicals are heated by means of embossed coils (Fig. CG-37-1). Upsetting grooves in the sheet metal of the two halves produce the spaces for the steam. When welded together, the halves form the passages for steam entry, heat transfer and condensate evacuation.

### Trap Selection for Embossed Coils

When two flowing liquids are separated and have two different temperatures, one of them increasing while the other is decreasing, there is a logarithmic temperature difference between the two liquids as between steam and a liquid (or the inlet and outlet of a heat exchanger) in  $t_m$ .

$$\Delta t_m = \frac{\Delta t_1 - \Delta t_2}{L_n \times \frac{\Delta t_1}{\Delta t_2}} \text{ where}$$

$\Delta t_1$  = the greatest temperature difference

$\Delta t_2$  = the least temperature difference

The  $L_n$  temperature difference can be determined with slightly less accuracy by using Chart CG-41-1 (page CG-41).

### EXAMPLE:

What is the logarithmic mean temperature difference of one liquid being heated from 74°C to 95°C and another liquid going from a temperature of 125°C down to 95°C.

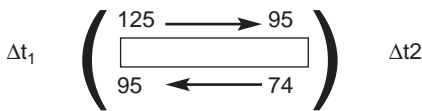

Type of Service	Circulation	
	Natural	Forced
Steam to Water	1 030 - 4 080	3 055 - 24 285
1 1/2" Tube Heaters	3 665	9 210
3/4" Tube Heaters	4 080	10 260
Steam to Oil	210 - 630	1 025 - 3 055
Steam to Boiling Liquid	6 070 - 16 330	-
Steam to Boiling Oil	1 025 - 3 055	-

Figure CG-37-1. Thermostatic Controlled Embossed Coil, Syphon Drained

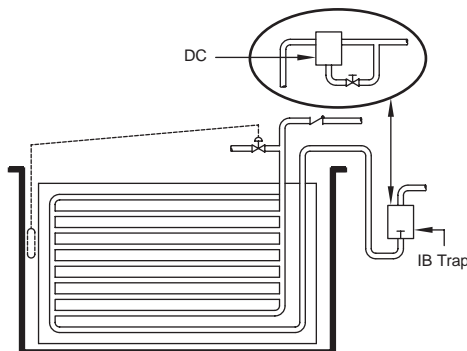

$$\Delta t_1 = 125 - 95 = 30^\circ\text{C}$$

$$\Delta t_2 = 95 - 74 = 21^\circ\text{C}$$

The logarithmic mean temperature difference is:

$$\Delta t_m = \frac{30 - 21}{\ln \times \frac{30}{21}} = \frac{9}{0,36} = 25^\circ\text{C}$$

To determine the total heat exchange, utilize the following formula:

$$H = A \times k \times \Delta t_m$$

### Where:

H = Heat transfer in kJ/h

A = Area in m<sup>2</sup>

k = Overall rate of heat transfer in kJ/h.m<sup>2</sup>.°C (Table CG-37-2)

$\Delta t_m$  = Logarithmic mean temperature difference

### EXAMPLE:

Heating area = 8 m<sup>2</sup>

Heat transfer = 3 770 kJ/h.m<sup>2</sup>.°C

Logarithmic mean temperature = 25°C

Steam pressure is 1,5 barg @ 125°C which gives a latent heat of 2 181 kJ/kg. 754 000 divided by 2 181 = 345,7 kg/h. To determine the proper trap required for this particular situation, multiply the condensate load by the appropriate safety factor.

Type of Service	Circulation	
	Natural	Forced
Steam to Watery Solutions	2 095 - 4 080	3 055 - 5 650
Steam to Light Oil	840 - 920	1 255 - 2 260
Steam to Medium Oil	420 - 840	1 025 - 2 050
Steam to Bunker C	335 - 630	840 - 1 675
Steam to Tar Asphalt	335 - 500	377 - 1 255
Steam to Molten Sulphur	500 - 710	710 - 920
Steam to Molten Paraffin	500 - 710	840 - 1 045
Steam to Molasses or Syrup	420 - 840	1 445 - 1 840
Downtherm to Tar Asphalt	335 - 630	1 025 - 1 255

Figure CG-37-2. Continuous Coil, Syphon Drained

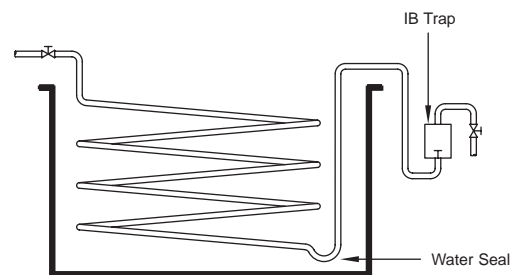



# How to Trap Shell & Tube Heat Exchangers & Submerged Coils

## Pipe Coils

Pipe coils are heat transfer tubes immersed in vessels that are large in volume compared to the coils themselves (Fig. CG-37-2, page CG-37). This is their primary difference when compared to shell and tube heat exchangers. Like embossed coils, they may be drained by gravity or syphon drained, depending on the conditions prevailing at the installation site. Unlike embossed coils, most pipe coils are installed in closed vessels.

## Trap Selection for Pipe Coils

Determine the condensate load for pipe coils by applying one of the formulas, depending on known data. If capacity is known, use the formula under shell and tube heat exchangers. When physical dimensions of coil are known, use the formula under embossed coils.

## Installation

When gravity drainage is utilized on shell and tube heat exchangers, embossed coils and pipe coils, locate the steam trap below the heating coil. Under modulating pressure, use a vacuum breaker. This can be integral in F&T traps or mounted off the inlet piping on an inverted bucket trap. Place an ample drip leg ahead of the trap to act as a reservoir. This ensures coil drainage when there is a maximum condensate load and a minimum steam pressure differential.

Avoid lifting condensate from a shell and tube heat exchanger, embossed coil or pipe coil under modulated control. However, if it must be done, the following is suggested:

1. Do not attempt to elevate condensate more than 0,2 bar of normal pressure differential, either before or after the trap.
2. If condensate lift takes place after the steam trap, install a low-pressure safety drain (See page CG-54).
3. If condensate lift takes place ahead of the steam trap (syphon lift), install an automatic differential condensate controller to efficiently vent all flash steam.

**Table CG-38-1. Recommendation Chart**  
(See Page CG-9 for "Feature Code" References.)

Equipment Being Trapped	1st Choice and Feature Code	Constant Pressure		1st Choice and Feature Code	Variable Pressure	
		0 - 2 barg	Above 2 barg		0 - 2 barg	Above 2 barg
Shell and Tube Heat Exchangers	B, C, E, F, G, I, K, N, Q	IBLV	IBLV	B, C, G, H, I, L	F&T†	F&T†
	Alternate Choice	DC F&T	DC *F&T	Alternate Choice	DC IBT	DC IBLV
Embossed Coils and Pipe Coils Syphon Drain	B, C, E, F, G, H, I, K, N, Q	DC	DC	B, C, G, H, I, L	DC	DC
	Alternate Choice	IBLV	IBLV	Alternate Choice	IBT	IBLV
Embossed Coils and Pipe Coils Gravity Drain	B, C, E, F, G, I, K, N, Q	IBLV	IBLV	B, C, G, H, I, L	F&T†	*F&T†
	Alternate Choice	DC F&T	DC F&T	Alternate Choice	DC IBT	DC IBLV

\* Use IBLV above pressure/temperature limitations.

† If dirt and large volumes of air must be handled, an inverted bucket trap with an external thermostatic air vent can be used effectively.

**Please Note:**

1. Provide vacuum breaker wherever subatmospheric pressures occur.
2. Provide a safety drain when elevating condensate on modulating service.

# How to Trap Evaporators

Evaporators reduce the water content from a product through the use of heat. They are very common to many industries, especially paper, food, textiles, chemical and steel.

An evaporator is a shell and tube heat exchanger where the steam is normally in the shell and the product is in the tubes and in motion. Depending upon the type of product and the desired results, more than one stage or effect of evaporation may be required. The triple effect is the most common, although as many as five or six can be found on some applications.

## Single Effect

While the product is being forced through the tubes of the evaporator, heat is added to remove a specific amount of moisture. After this is completed, both the product vapor and the concentrated product are forced into the separating chamber where the vapor is drawn off and may be used elsewhere. The concentrate is then pumped off to another part of the process (Fig. CG-31-1).

## Multiple Effect

In using the multiple effect method, there is a conservation of heat as steam from the boiler is used in the first effect, and then vapor generated from the product is used as the heat source in the second effect. The vapor generated here is then used as the heat source in the third effect and finally heats water for some other process or preheats the incoming feed (Fig. CG-39-2).

There are many variables in the design of evaporators due to their wide application to many different products. The steam capabilities for evaporators can vary from approximately 500 kg/h to 50 000 kg/h, while steam pressures may vary from a high of 10 barg in the first effect to a low of 60 cm vacuum in the last effect.

Because evaporators are normally run continuously, there is a uniform load of condensate to be handled. It's important to remember that traps must be selected for the actual pressure differential for each effect.

The three major considerations when trapping evaporators are:

1. Large condensate loads.
2. Low pressure differentials in some effects.
3. The evacuation of air and contaminants.

## Safety Factor

- When load is fairly constant and uniform, a 2:1 safety factor should be adequate when applied to an actual condensing load in excess of 25 000 kg/h.
- Below 25 000 kg/h, use a 3:1 safety factor.

For single and multiple effect evaporators, automatic differential condensate controllers are recommended. In addition to offering continuous operation, DC traps vent air and CO<sub>2</sub> at steam temperature, handle flash steam and respond immediately to slugs of condensate.

Figure CG-39-1. Single Effect Evaporator System

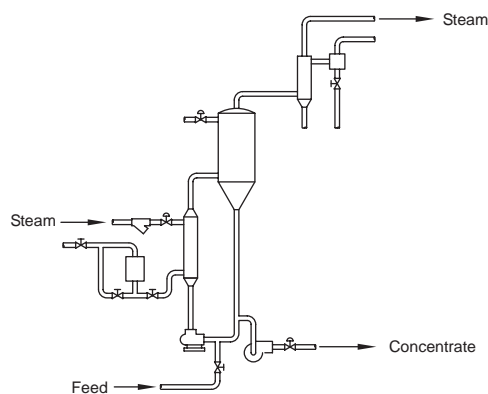

Figure CG-39-2. Triple Effect Evaporator System

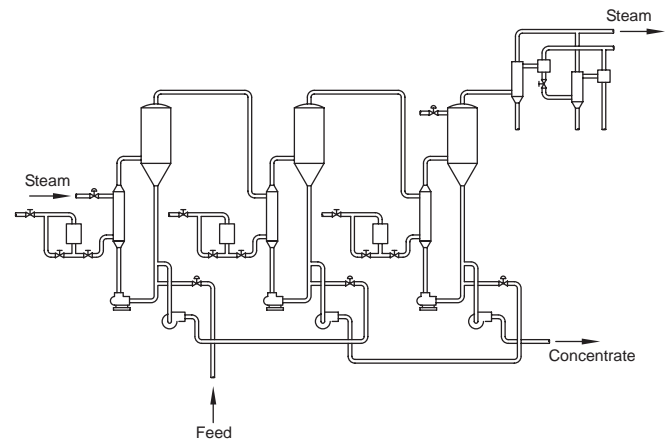

Table CG-39-1. Recommendation Chart (See Page CG-9 for "Feature Code" References.)			
Equipment Being Trapped	1st Choice, Feature Code and Alternate Choice(s)	0 - 2 barg	Above 2 barg
Evaporator Single Effect	A, F, G, H, K, M, P	DC	DC
	Alternate Choices	IBLV F&T	IBLV F&T
Evaporator Multiple Effect	A, F, G, H, K, M, P	DC	DC
	Alternate Choices	IBLV F&T	IBLV F&T





# How to Trap Evaporators

## Installation

Because an evaporator is basically a shell and tube heat exchanger with the steam in the shell, there should be separate steam air vents on the heat exchanger. Place these vents at any area where there is a tendency for air to accumulate, such as in the quiet zone of the shell. Install a separate trap on each effect. While the condensate from the first effect may be returned to the boiler, condensate from each successive effect may not be returned to the boiler due to contamination from the product.

## Trap Selection for Evaporators

When calculating the condensate load for evaporators, take care in selecting the k value (kJ/h.m<sup>2</sup>.°C). As a general rule, the following k values can be used:

- 5 860 for natural circulation evaporators with low pressure steam (up to 2 barg)
- 10 050 on natural circulation with high pressure (up to 3 barg)
- 15 070 with forced circulation evaporators

Use the following formula to compute heat transfer for constant steam pressure continuous flow heat exchangers.

$$H = A \times k \times \Delta t_m$$

### Where:

- H = Total heat transferred in kJ per hour
- A = Area of outside surface of coil in m<sup>2</sup>
- k = Overall rate of heat transfer in kJ/h.m<sup>2</sup>.°C (See Tables CG-37-1 and CG-37-2)
- $\Delta t_m$  = Logarithmic mean temperature difference between steam and liquid (as between inlet and outlet of a heat exchanger) in °C

$$\Delta t_m = \frac{\Delta t_1 - \Delta t_2}{L_n \times \frac{\Delta t_1}{\Delta t_2}}$$

### Where:

- $\Delta t_1$  = Greatest temperature difference
- $\Delta t_2$  = Least temperature difference

Logarithmic mean temperature difference can be estimated by using the nomograph, Chart CG-41-1.

## EXAMPLE:

A = Heat transfer tubes: eight 3/4" OD tubes 3,6 m long

$$\frac{8 \times 3,6}{16,7} = 1,7 \text{ m}^2$$

(from Table CG-22)

$$k = 10\,260 \text{ kJ/h.m}^2.\text{°C}$$

Conditions:

- Water in: 4,5°C
- Water out: 65,5°C

8,5 barg steam or 178,3°C steam temperature:

$$\Delta t_1 = 178,3^\circ\text{C} - 4,5^\circ\text{C} = 173,8^\circ\text{C}$$

$$\Delta t_2 = 178,3^\circ\text{C} - 65,5^\circ\text{C} = 112,8^\circ\text{C}$$

Dividing by 4 to get within range of Chart CG-41-1, we have:

$$\Delta t_1 = 43,5^\circ\text{C}$$

$$\Delta t_2 = 28,2^\circ\text{C}$$

Mean difference from chart is 35°C. Multiplying by 4, the mean temperature difference for the original value is 140°C. Substituting in the equation:

$$H = 1,7\text{m}^2 \times 10\,260 \text{ kJ/h.m}^2.\text{°C} \times 140^\circ\text{C} = 2\,441\,880 \text{ kJ/h}$$

Latent heat of steam at 8,5 barg = 2 018 kJ/kg

$$\frac{2\,441\,880 \text{ kJ/h}}{2\,018 \text{ kJ/kg}} = 1\,210 \text{ kg/h}$$

To determine trap capacity required, multiply the condensing rate by the recommended safety factor.

# How to Trap Evaporators

Table CG-41-1. Pipe Coil k Values in kJ/h.m <sup>2</sup> .°C		
Type of Service	Circulation	
	Natural	Forced
Steam to Water	1 030 - 4 080	3 055 - 24 285
1 1/2" Tube Heaters	3 665	9 210
3/4" Tube Heaters	4 080	10 260
Steam to Oil	210 - 630	1 025 - 3 055
Steam to Boiling Liquid	6 070 - 16 330	-
Steam to Boiling Oil	1 025 - 3 055	-

Table CG-41-2. Embossed Coil k Values in kJ/h.m <sup>2</sup> .°C		
Type of Service	Circulation	
	Natural	Forced
Steam to Watery Solutions	2 095 - 4 080	3 055 - 5 650
Steam to Light Oil	840 - 920	1 255 - 2 260
Steam to Medium Oil	420 - 840	1 025 - 2 050
Steam to Bunker C	335 - 630	840 - 1 675
Steam to Tar Asphalt	335 - 500	377 - 1 255
Steam to Molten Sulphur	500 - 710	710 - 920
Steam to Molten Paraffin	500 - 710	840 - 1 045
Steam to Molasses or Syrup	420 - 840	1 445 - 1 840
Downtherm to Tar Asphalt	335 - 630	1 025 - 1 255

Table CG-41-3. Pipe Size Conversion Table		
(Divide lineal meters of pipe by factor given for size and type of pipe to get square meters of surface).		
Pipe size (mm)	Iron Pipe	Copper or Brass Pipe
15	14,92	25,03
20	11,94	16,70
25	9,51	12,53
32	7,54	10,00
40	6,59	8,36
50	5,28	6,26
65	4,36	4,99
80	3,58	4,17
100	2,78	3,13

Chart CG-41-1. Mean Temperature Difference Chart for Heat Exchange Equipment

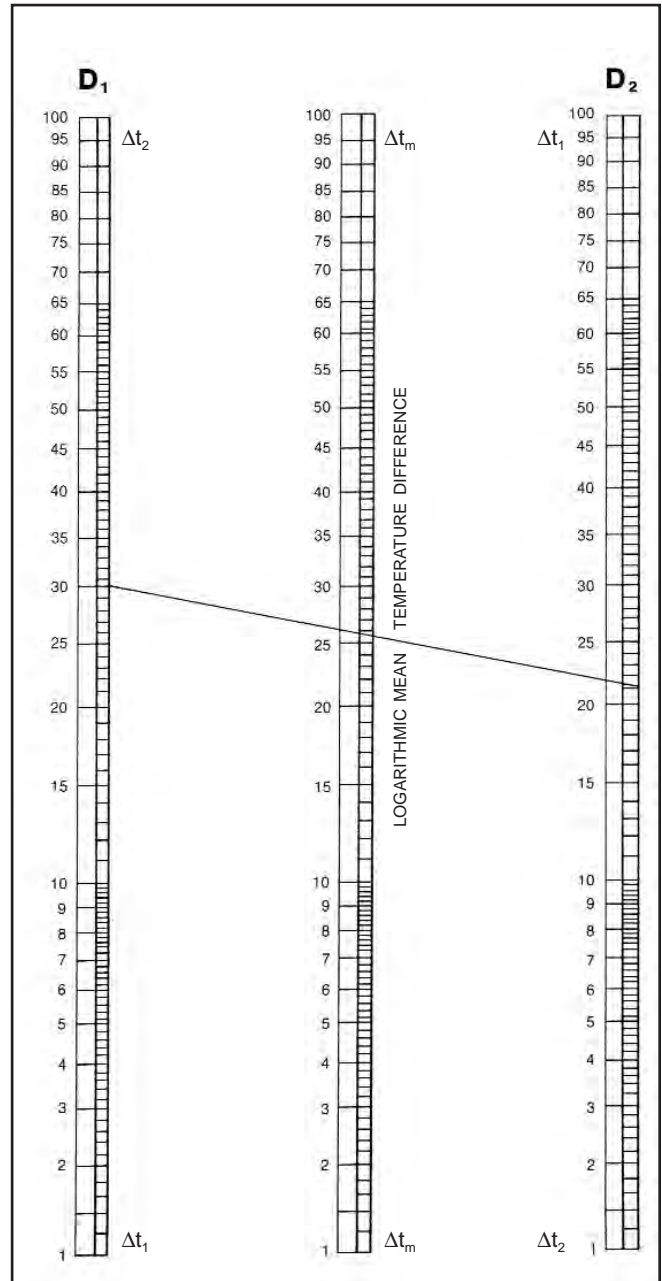

Connect greatest temperature difference on scale **D<sub>1</sub>** with least temperature difference on scale **D<sub>2</sub>** to read logarithmic mean temperature difference on center scale.



# How to Trap Jacketed Kettles

Steam Conservation Guidelines

Steam jacketed kettles are essentially steam jacketed cookers or concentrators. They are found in all parts of the world and in almost every kind of application: meat packing, paper and sugar making, rendering, fruit and vegetable processing and food preparation – to name a few.

There are basically two types of steam jacketed kettles – fixed gravity drain and tilting syphon drain. Each type requires a specialized method for trapping steam, although the major problems involved are common to both.

The most significant problem encountered is air trapped within the steam jacket, which adversely affects the temperature. Jacketed kettles usually perform batch operations, and maintaining a uniform or “cooking” temperature is critical. With an excessive amount of air, wide variations in temperature occur and may result in burnt product and/or slow production. To be more specific, under certain conditions as little as 1/2 of 1% by volume of air in steam can form an insulating film on the heat transfer surface and reduce efficiency as much as 50%. See pages CG-14 and CG-15.

A second basic concern in the use of steam jacketed kettles is the need for a steady, thorough removal of condensate. Accumulation of condensate in the jacket leads to unreliable temperature control, reduces the output of the kettle and causes water hammer.

## Trap Selection for Jacketed Kettles

The required trap capacity for kettles can be determined through use of the following formula:

$$Q_c = \frac{k \times A \times \Delta t}{r}$$

### Where:

- $Q_c$  = Condensate loads in kg/h
- $k$  = Heat transfer rate in kJ/h.m<sup>2</sup>.°C
- $A$  = Area in m<sup>2</sup>
- $\Delta t$  = Temperature rise of the liquid °C
- $r$  = Latent heat of the steam in kJ/kg

**EXAMPLE:** What would be the recommended trap capacity for a gravity drained kettle with an inside diameter of 800 mm and an operating steam pressure of 7 barg heating a liquid from 20°C to 80°C ? Using the formula:

$$Q_c = \frac{3\,560 \times 1,18 \times 60}{2\,047} = 123 \text{ kg/h}$$

- $k$  = 3 560 kJ/h.m<sup>2</sup>.°C assumed k factor for stainless steel.
- $A$  = 1,18 m<sup>2</sup> (given by kettle manufacturer)

Now simply multiply by a safety factor of 3 to get 369 kg/h of condensate and select the proper type and capacity trap.

For an alternative method of determining condensate, use the following formula:

$$Q_c = \frac{V \times \text{s.g.} \times c \times \Delta t}{r \times h} \times 60$$

### Where:

- $Q_c$  = Condensate loads in kg/h
- $V$  = Liters of liquid to be heated
- s.g.= Specific gravity of the liquid in kg/m<sup>3</sup>
- $c$  = Specific heat of the liquid in kJ/kg/°C
- $\Delta t$  = Temperature rise of the liquid °C
- $r$  = Latent heat of the steam in kJ/kg (see Steam Tables,

column 5 on page CG-10)

$h$  = Time in hours for product heating

**EXAMPLE:** Select a trap for a 1000 liters kettle using 0,5 barg steam to heat a product (milk) with a specific gravity of 1,03 and a specific heat of 3,77 kJ/kg/°C (Table CG-60-1, page CG-60). Starting at room temperature of 20°C, the product will be heated to 80°C in 30 minutes. Using the formula:

$$Q_c = \frac{1\,000 \text{ l} \times 1,03 \text{ kg/m}^3 \times 3,77 \text{ kJ/kg/}^\circ\text{C} \times 60^\circ\text{C}}{2\,226 \text{ kJ/kg} \times 0,5 \text{ h}} = 211 \text{ kg/h}$$

Now simply multiply by a safety factor of 3 to get 633 kg/h of condensate and select the proper type and capacity trap.

Based on the standard requirements and problems involved with fixed gravity drained kettles, the most efficient type trap to use is the inverted bucket.

The inverted bucket trap vents air and CO<sub>2</sub> at steam temperature and provides total efficiency against back pressure. The primary recommendation for tilting syphon drained kettles is the automatic differential condensate controller. In addition to providing the same features as the IB, the DC offers excellent air venting ability at very low pressure and excellent flash steam handling ability. If an IB trap is selected for syphon drained service, use a trap one size larger.

## General Recommendations for Maximum Efficiency

**Desirable Cooking Speed.** Because the product cooked has such an important bearing on trap selection, a plant with many jacketed kettles should conduct experiments using different sizes of traps to determine the size giving best results.

**Steam Supply.** Use steam lines of ample size to supply steam to the kettles. Locate the inlet nozzle high up on the jacket for best results. It should be slotted so as to give steam flow around the entire jacket area.

## Installation

Install traps close to the kettle. You can further increase the dependability and air-handling capability by installing a thermostatic air vent at high points in the jacket. See Figs. CG-43-1 and CG-43-2.

Never drain two or more kettles with a single trap. Group drainage will invariably result in short circuiting.

**Table CG-42-1. Recommendation Chart**  
(See Page CG-9 for “Feature Code” References.)

Equipment Being Trapped	1st Choice and Feature Code	Alternate Choice
Jacketed Kettles Gravity Drain	IBLV B, C, E, H, K, N	F&T or Thermostatic
Jacketed Kettles Syphon Drain	DC B, C, E, G, H, K, N, P	IBLV

# How to Trap Jacketed Kettles



Figure CG-43-1. Fixed Gravity Drained Kettle

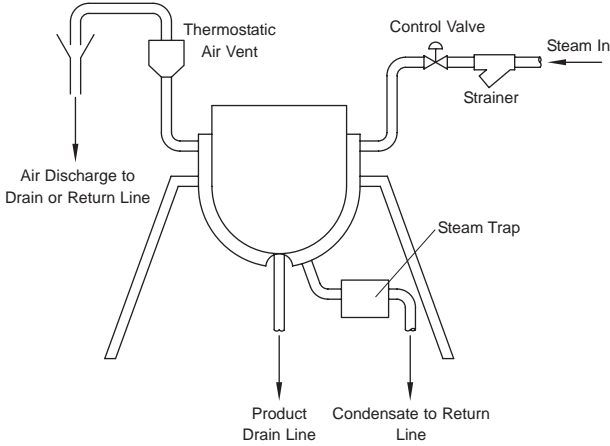
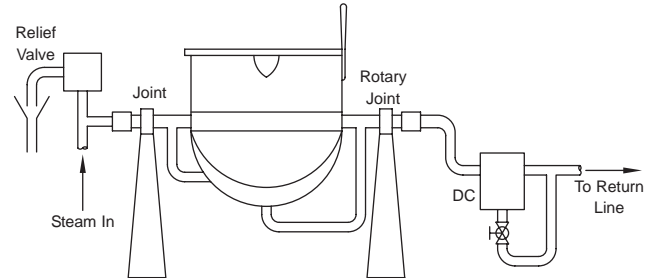

Figure CG-43-2. Tilting Syphon Drained Kettle



**Table CG-43-1. Condensate Rates in kg/h for Jacketed Kettles - Hemispherical condensing surface**  
 Safety factor 3:1 is included. Assume  $k = 3\,600 \text{ kJ/h.m}^2.\text{°C}$ ,  $10\text{°C}$  starting temperature

Kettle Diameter (mm)	Heat Transfer Surface (m <sup>2</sup> )	Liters of Water in Hemisphere	Liters of Water per mm of height above Hemisphere	Steam Pressure (barg)								
				0,35 108°C	0,7 115°C	1 120°C	1,7 130°C	2,5 139°C	4 152°C	5 159°C	7 170°C	8,5 178°C
460	0,33	26,5	0,16	154	166	176	193	215	237	256	274	291
485	0,36	30,3	0,18	172	185	196	217	240	264	286	304	324
510	0,40	34,1	0,20	191	207	219	241	267	296	319	339	362
560	0,49	45,4	0,25	233	252	267	294	326	360	388	414	441
610	0,59	60,6	0,29	276	300	317	349	387	428	462	492	524
660	0,69	75,7	0,34	326	351	373	410	455	503	542	577	616
710	0,79	94,6	0,39	373	405	428	471	522	576	622	663	707
760	0,91	117,4	0,45	430	466	494	543	602	665	718	765	816
815	1,04	140,1	0,52	493	533	564	621	688	760	821	874	932
865	1,17	170,3	0,59	554	599	635	699	774	854	883	983	1 049
915	1,31	200,6	0,66	620	670	711	782	866	956	1 034	1 100	1 174
965	1,46	234,7	0,73	691	746	791	870	964	1 065	1 151	1 226	1 306
1 015	1,62	276,3	0,81	765	827	877	964	1 069	1 181	1 275	1 358	1 448
1 070	1,78	318,0	0,89	844	913	967	1 064	1 179	1 302	1 407	1 498	1 598
1 120	1,96	367,2	0,98	928	1 002	1 064	1 170	1 297	1 431	1 546	1 647	1 756
1 170	2,14	416,4	1,07	1 012	1 094	1 159	1 275	1 412	1 559	1 685	1 795	1 914
1 220	2,35	465,6	1,17	1 113	1 203	1 275	1 401	1 554	1 716	1 854	1 975	2 106
1 370	2,94	673,8	1,48	1 397	1 509	1 599	1 759	1 950	2 153	2 327	2 478	2 642
1 525	3,64	927,4	1,83	1 724	1 863	1 975	2 172	2 408	2 659	2 872	3 059	3 262
1 830	5,24	1 601,2	1,89	2 483	2 683	2 844	3 128	3 468	3 829	4 136	4 405	4 697



# How to Trap Closed, Stationary Steam Chamber Equipment

Closed, stationary steam chamber equipment includes platen presses for the manufacture of plywood and other sheet products, steam jacketed molds for rubber and plastic parts, autoclaves for curing and sterilizing and retorts for cooking.

### Product Confined in Steam Jacketed Press

Molded plastic and rubber products such as battery cases, toys, fittings and tires are formed and cured, and plywood is compressed and glue-cured in equipment of this type. Laundry flatwork ironers are a specialized form of press with a steam chamber on one side of the product only.

### Trap Selection and Safety Factor

The condensate load for closed, stationary steam chamber equipment is determined by use of the following formula:

$$Q_c = A \times R \times SF$$

#### Where:

- $Q_c$  = Condensate load in kg/h
- $A$  = Total area of platen in contact with product in  $m^2$
- $R$  = Condensing rate in  $kg/h/m^2$  (For purposes of sizing steam traps, a  $35 kg/h/m^2$  condensing rate may be used)
- $SF$  = Safety factor

**EXAMPLE:** What is the condensate load for a mid platen on a press with a 600 x 900 mm platen? Using the formula:

$$Q_c = 0,54 m^2 \times 35 kg/h/m^2 \times 3 = 56,7 kg/h$$

End platens would have half this load.

**The safety factor recommended for all equipment of this type is 3:1.**

The inverted bucket trap is the recommended first choice on steam jacketed chambers, dryers and ironers because it can purge the system, resist hydraulic shock and conserve energy. Disc and thermostatic type traps may be acceptable alternatives.

### Installation

Although the condensate load on each platen is small, individual trapping is essential to prevent short circuiting, Fig. CG-44-1. Individual trapping ensures maximum and uniform temperature for a given steam pressure by efficiently draining the condensate and purging the non-condensables.

### Direct Steam Injection Into Product Chamber

This type of equipment combines steam with the product in order to cure, sterilize or cook. Common examples are autoclaves used in the production of rubber and plastic products, sterilizers for surgical dressings and gowns, and retorts for cooking food products already sealed in cans.

### Trap Selection and Safety Factor

Calculate the condensate load using the following formula:

$$Q_c = \frac{W \times c \times \Delta t}{r \times h}$$

#### Where:

- $Q_c$  = Condensate load in kg/h
- $W$  = Weight of the product in kg
- $c$  = Specific heat of the product in  $kJ/kg/^\circ C$  (Table CG-60-1, page CG-60)
- $\Delta t$  = Product temperature rise in  $^\circ C$
- $r$  = Latent heat of steam in  $kJ/kg$  (see Steam Tables, column 5 on page CG-10)
- $h$  = Time in hours

**EXAMPLE:** What will be the condensate load on an autoclave containing 100 kg of rubber product which must be raised to a temperature of  $150^\circ C$  from a starting temperature of  $20^\circ C$ ? The autoclave operates at 8 barg steam pressure and the heat-up process takes 20 minutes. Using the formula:

$$Q = \frac{100 kg \times 2,1 kJ/kg/^\circ C \times 130^\circ C}{2 029 kJ/kg \times 0,33} = 41 kg/h$$

Multiply by a recommended safety factor of 3:1 to get the required capacity - 123 kg/h.

Figure CG-44-1. Product Confined In Steam Jacketed Press

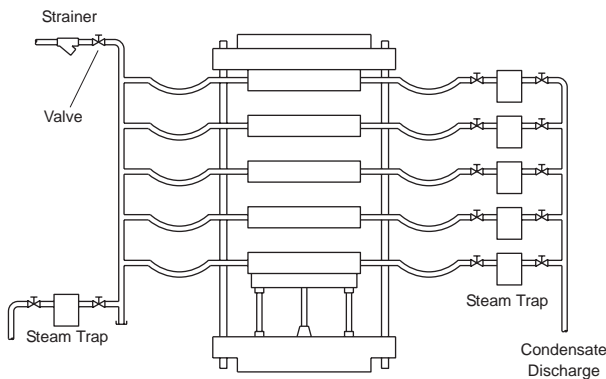

# How to Trap Closed, Stationary Steam Chamber Equipment



Since steam is in contact with the product, you can anticipate dirty condensate. In addition, the vessel is a large volume chamber that requires special consideration in the purging of condensate and non-condensables. For these reasons, an inverted bucket trap with an auxiliary thermostatic air vent installed at the top of the chamber is recommended.

Where no remote thermostatic air vent can be installed, incorporate the large volume air purging capabilities in the steam trap itself. An automatic differential condensate controller should be considered a possible first choice on large chambers. As an alternative, an F&T or thermostatic trap should be used and be preceded by a strainer, the latter receiving regular checks for free flow.

## Installation

Because the steam and condensate is in contact with the product, the trap discharge should almost always be disposed of by some means other than return to the boiler. In virtually all cases this equipment is gravity drained to the trap. However, very often there is a condensate lift after the trap. Because steam pressure is usually constant, this does not present a problem. For thorough air removal and quicker warm-up, install a thermostatic air vent at a high point of the vessel. See Fig. CG-45-1.

## Product in Chamber – Steam in Jacket

Autoclaves, retorts and sterilizers are also common examples of this equipment; however, the condensate is not contaminated from actual contact with the product and can be returned directly to the boiler. Steam traps with purging ability and large volume air venting are still necessary for efficient performance.

## Trap Selection and Safety Factor

Size steam traps for “product in chamber – steam in jacket equipment” by using the same formula outlined for direct steam injection. The safety factor is also 3:1.

The inverted bucket trap is recommended because it conserves steam, purges the system and resists hydraulic shock.

Use the IB trap in combination with a thermostatic air vent at the top of the chamber for greater air-handling capability. As an alternative, an F&T or thermostatic trap could be used. On large chambers, where it’s not possible to install the air vent, an automatic differential condensate controller should be considered a possible first choice.

## Installation

With “product in chamber – steam in jacket equipment”, the steam and condensate do not come in contact with the product and can be piped to the condensate return system. Where possible, install an auxiliary thermostatic air vent at a remote high point on the steam chamber. See Fig. CG-45-2.

**Table CG-45-1. Recommendation Chart**  
(See Page CG-9 for “Feature Code” References.)

Equipment Being Trapped	1st Choice and Feature Code	Alternate Choices
Product Confined Steam Jacketed Press	IB A, B, E, K	CD and Thermostatic
Direct Steam Injection into Product Chamber	*IB A, B, E, H, K, N, Q	**DC
Product in Chamber - Steam in Jacket	*IB A, B, E, H, K	Thermostatic and F&T and **DC

\* An auxiliary air vent is recommended.

\*\* First choice on large volume vessels.

Figure CG-45-1. Direct Steam Injection Into Product Chamber

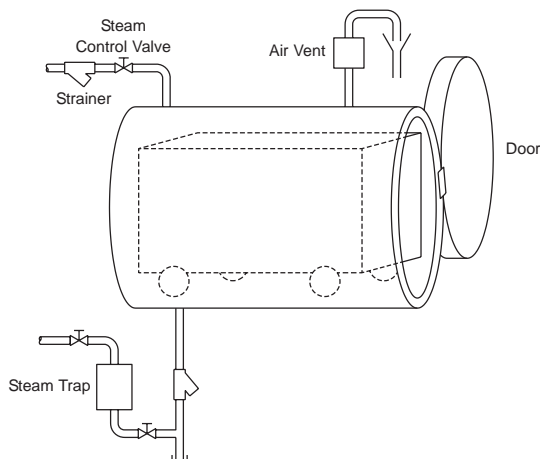
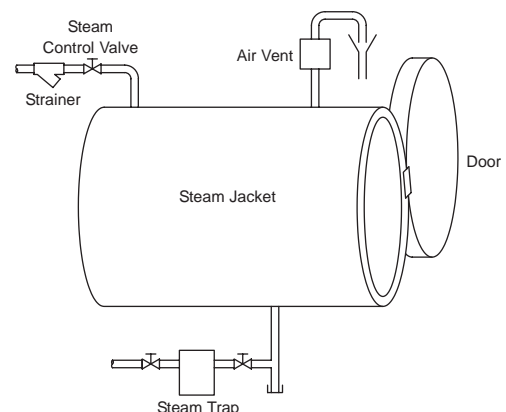

Figure CG-45-2. Product in Chamber - Steam in Jacket



There are two classifications of rotating dryers which vary significantly in both function and method of operation. The first dries a product by bringing it into contact with the outside of a steam-filled cylinder. The second holds the product inside a rotating cylinder where steam-filled tubes are used to dry it through direct contact. In some applications a steam jacket surrounding the cylinder is also used.

### Safety Factor

The safety factor for both kinds of dryers depends on the type of drainage device selected.

- If an automatic differential condensate controller (DC) is installed, use a safety factor of 3:1 based on the maximum load. This will allow sufficient capacity for handling flash steam, large slugs of condensate, pressure variations and the removal of non-condensables. The DC performs these functions on both constant and modulated pressure.
- If an inverted bucket trap with large vent is used, increase the safety factor in order to compensate for the large volume of non-condensable and flash steam that will be present. Under constant-pressure conditions, use a safety factor of 8:1. On modulated pressure increase it to 10:1.

### Rotating Steam Filled Cylinder with Product Outside

These dryers are used extensively in the paper, textile, plastic and food industries, where common examples are dry cans, drum dryers, laundry ironers and paper machine dryers. Their speed of operation varies from 1 or 2 rpm to surface velocities as high as 5 000 rpm. Operating steam pressure ranges from subatmospheric to more than 14 barg. Diameters can vary from 150 mm or 200 mm to 4 000 mm more. In all cases syphon drainage is required and flash steam will accompany the condensate.

### Trap Selection

Condensate loads can be determined by use of the following formula:

$$Q_c = \pi d \times R \times W$$

#### Where:

- $Q_c$  = Condensate load in kg/h
- $d$  = Diameter of the dryer in m
- $R$  = Rate of condensation in kg/h/m<sup>2</sup>
- $W$  = Width of dryer in m

**EXAMPLE:** Determine the condensate load of a dryer 1 500 mm in diameter, 3 000 mm in width and a condensing rate of 35 kg/h/m<sup>2</sup>. Using the formula:

$$\text{Condensate load} = \pi(1,5) \times 35 \times 3 = 495 \text{ kg/h}$$

Based on its ability to handle flash steam, slugs of condensate and purge the system, a DC is the recommended first choice. An IBLV may be adequate if proper sizing procedures are followed.

Table CG-46-1. Recommendation Chart (See Page CG-9 for "Feature Code" References.)		
Equipment Being Trapped	1st Choice and Feature Code	Alternate Choices
Rotating Dryers	DC A, B, K, M, P, N	IBLV*

\* On constant pressure use 8:1 safety factor, and on modulated pressure use 10:1

Figure CG-46-1. Product Outside Dryer

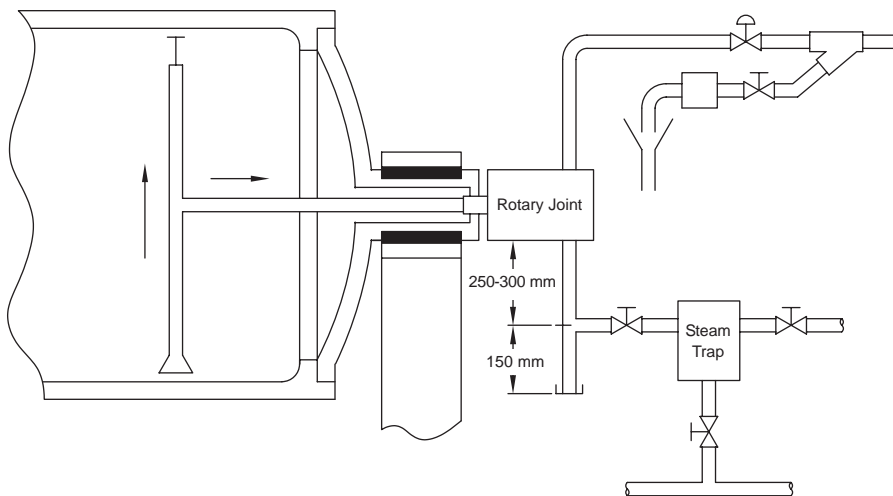

A revolving cylinder drained with a syphon - an internal syphon surrounded by steam. Some condensate flashes back to steam due to the steam jacketed syphon pipe and syphon lifting during evacuation.

# How to Trap Rotating Dryers Requiring Syphon Drainage



## Product Inside a Rotating Steam Heated Dryer

This type of dryer finds wide application in meat packing as well as food processing industries. Common examples are grain dryers, rotary cookers and bean conditioners.

Their speed of rotation is relatively slow, usually limited to a few rpm, while steam pressure may range from 0 - 10 barg. These slower rotating speeds permit the condensate to accumulate in the bottom of the collection chamber in practically all cases. Again, syphon drainage is required and flash steam is generated during condensate removal.

## Trap Selection

The condensate load generated by these dryers can be determined through use of the following formula:

$$Q_c = N \times L \times R \times S$$

### Where:

$Q_c$  = Condensate in kg/h

N = Number of tubes

L = Length of tubes in m

R = Condensing rate in kg/h/m<sup>2</sup> (typical 30 - 45 kg/h/m<sup>2</sup>)

S = Outside surface of the pipe in m<sup>2</sup>/m (see Table CG-47-1)

**EXAMPLE:** What will be the condensate load on a rotary cooker containing 30 1 1/4" steel pipes 3 m in length with a condensing rate of 40 kg/h/m<sup>2</sup>?

Using the formula:

$$Q = 30 \times 3 \text{ m} \times 40 \text{ kg/h/m}^2 \times 0,13 \text{ m}^2/\text{m} = 468 \text{ kg/h}$$

A differential controller is recommended on these dryers for its purging and flash steam handling ability.

The IBLV again requires proper sizing for certain applications.

## Installation

In all cases, condensate drainage is accomplished through a rotary joint, Figs. CG-46-1 and CG-47-1. The DC should then be located 250 - 300 mm below the rotary joint with an extended 150 mm dirt pocket. These provide a reservoir for surges of condensate and also a pocket for entrained scale.

**Table CG-47-1. Pipe characteristics for Radiation Loss Calculation**

Pipe Size		Outside Diameter	Outside Surface	Weight
Inches	DN	mm	m <sup>2</sup> /m	kg/m
1/8"	6	10,2	0,03	0,49
1/4"	8	13,5	0,04	0,77
3/8"	10	17,2	0,05	1,02
1/2"	15	21,3	0,07	1,45
3/4"	20	26,9	0,09	1,90
1"	25	33,7	0,11	2,97
1 1/4"	32	42,4	0,13	3,84
1 1/2"	40	48,3	0,15	4,43
2"	50	60,3	0,19	6,17
2 1/2"	65	76,1	0,24	7,90
3"	80	88,9	0,28	10,10
4"	100	114,3	0,36	14,40
5"	125	139,7	0,44	17,80
6"	150	165,1	0,52	21,20
8"	200	219,0	0,69	31,00
10"	250	273,0	0,86	41,60
12"	300	324,0	1,02	55,60
14"	350	355,0	1,12	68,30
16"	400	406,0	1,28	85,90
20"	500	508,0	1,60	135,00

**Figure CG-47-1. Product Inside Dryer**

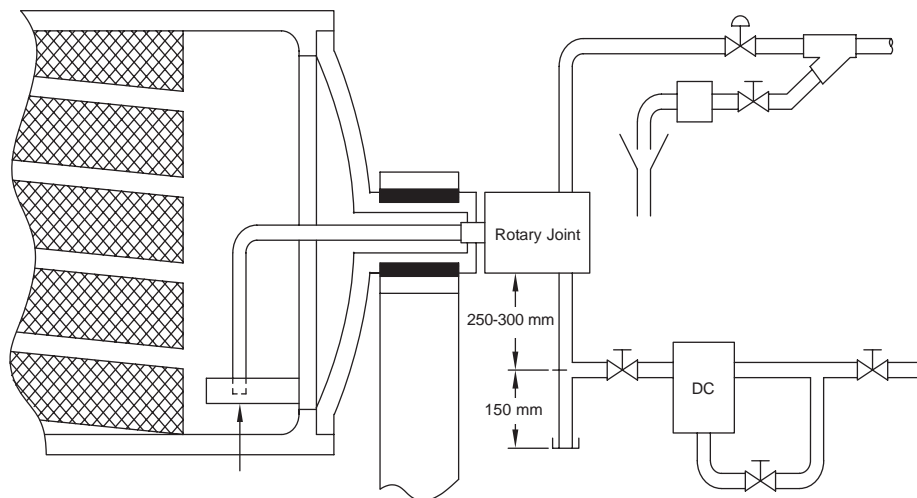

A revolving cylinder drained with a syphon – an internal syphon surrounded by steam. Some condensate flashes back to steam due to the steam jacketed syphon pipe and syphon lifting during evacuation.





# How to Trap Flash Tanks

When hot condensate or boiler water, under pressure, is released to a lower pressure, part of it is re-evaporated, becoming what is known as flash steam. The heat content of flash is identical to that of live steam at the same pressure, although this valuable heat is wasted when allowed to escape through the vent in the receiver. With proper sizing and installation of a flash recovery system, the latent heat content of flash steam may be used for space heating; heating or preheating water, oil and other liquids; and low pressure process heating.

If exhaust steam is available it may be combined with the flash. In other cases, the flash will have to be supplemented by live make-up steam at reduced pressure. The actual amount of flash steam formed varies according to pressure conditions. The greater the difference between initial pressure and pressure on the discharge side, the greater the amount of flash that will be generated.

To determine the exact amount, as a percentage, of flash steam formed under certain conditions, refer to page CG-11 for complete information.

### Trap Selection

The condensate load can be calculated using the following formula:

$$Q_c = L - \frac{L \times P}{100}$$

#### Where:

- $Q_c$  = Condensate load in kg/h (to be handled by steam trap)
- $L$  = Condensate flow into flash tank in kg/h
- $P$  = Percentage of flash

**EXAMPLE:** Determine the condensate load of a flash tank with 2 300 kg/h of 7 barg condensate entering the flash tank held at 0,7 barg. From page CG-11, the flash percentage is  $P = 10,5\%$ . Using the formula:

$$Q = 2\,300 - \frac{(2\,300 \times 10,5)}{100} = 2\,059 \text{ kg/h}$$

Due to the importance of energy conservation and operation against back pressure, the trap best suited for flash steam service is the inverted bucket type with large bucket vent. In addition, the IB operates intermittently while venting air and  $CO_2$  at steam temperature.

In some cases, the float and thermostatic type trap is an acceptable alternative. One particular advantage of the F&T is its ability to handle heavy start-up air loads.

Refer to Chart CG-11-1 (page CG-11) for percentage of flash steam formed when discharging condensate to reduced pressure.

A third type of device that may be the preferred selection in many cases is the automatic differential condensate controller. It combines the best features of both the IB and F&T and is recommended for large condensate loads that exceed the separating capability of the flash tank.

### Safety Factor

The increased amount of condensate at start-up and the varying loads during operation accompanied by low pressure differential dictates a safety factor of 3:1 for trapping flash tanks.

Figure CG-48-1. Typical Flash Tank Piping Sketch

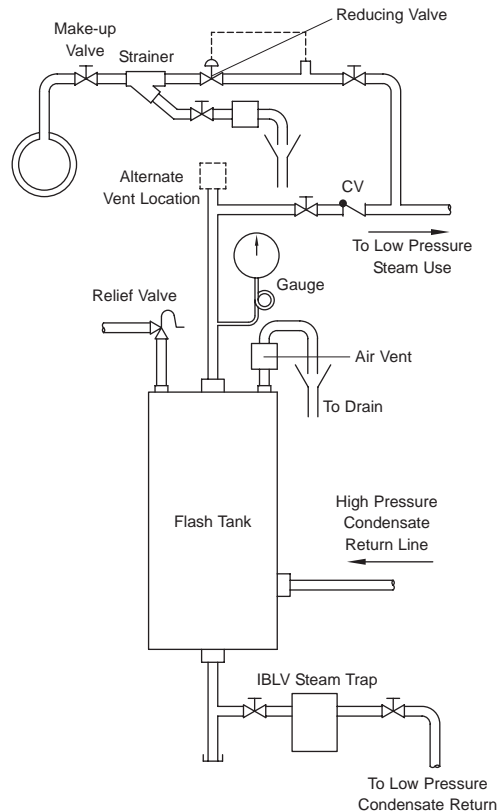

Table CG-48-1. Recommendation Chart (See Page CG-9 for "Feature Code" References.)		
Equipment Being Trapped	1st Choice and Feature Code	Alternate Choice
Flash Tanks	IBLV B, E, M, L, I, A, F	F&T or *DC

\* Recommended where condensate loads exceed the separating capability of the flash tank.

Flash steam tank with live steam make-up, showing recommended fittings and connections. The check valves in the incoming lines prevent waste of flash when a line is not in use. The by-pass is used when flash steam cannot be used. Relief valves prevent pressure from building up and interfering with the operation of the high pressure steam traps. The reducing valve reduces the high pressure steam to the same pressure as the flash, so they can be combined for process work or heating.

# How to Trap Flash Tanks

## Installation

Condensate return lines contain both flash steam and condensate. To recover the flash steam, the return header runs to a flash tank, where the condensate is drained, and steam is then piped from the flash tank to points of use, Fig. CG-56. Since a flash tank causes back pressure on the steam traps discharging into the tank, these traps should be selected to ensure their capability to work against back pressure and have sufficient capacity at the available differential pressures.

Condensate lines should be pitched toward the flash tank, and where more than one line feeds into a flash tank, each line should be fitted with a swing check valve. Then, any line not in use will be isolated from the others and will not be fed in reverse with resultant wasted flash steam. If the trap is operating at low pressure, gravity drainage to the condensate receiver should be provided.

Generally, the location chosen for the flash tank should meet the requirement for maximum quantity of flash steam and minimum length of pipe.

Condensate lines, the flash tank, and the low pressure steam lines should be insulated to prevent waste of flash through radiation. The fitting of a spray nozzle on the inlet pipe inside the tank is not recommended. It may become choked, stop the flow of condensate, and produce a back pressure to the traps.

Low pressure equipment using flash steam should be individually trapped and discharged to a low pressure return. Large volumes of air need to be vented from the flash tank; therefore, a thermostatic air vent should be used to remove the air and keep it from passing through the low pressure system.

## Flash Tank Dimensions

The flash tank can usually be conveniently constructed from a piece of large diameter piping with the bottom ends welded or bolted in position. The tank should be mounted vertically. A steam outlet is required at the top and a condensate outlet at the bottom. The condensate inlet connection should be 150 - 200 mm above the condensate outlet.

The important dimension is the inside diameter. This should be such that the upward velocity of flash to the outlet is low enough to ensure that the amount of water carried over with the flash is small. If the upward velocity is kept low, the height of the tank is not important, but good practice is to use a height of 700 - 1 000 mm.

It has been found that a steam velocity of about 3 m per second inside the flash tank will give good separation of steam and water. On this basis, proper inside diameters for various quantities of flash steam have been calculated; the results are plotted in Chart CG-49-1. This curve gives the smallest recommended internal diameters. If it is more convenient, a larger tank may be used.

Chart CG-49-1 does not take into consideration pressure - only weight. Although volume of steam and upward velocity are less at a higher pressure, because steam is denser, there is an increased tendency for priming. Thus it is recommended that, regardless of pressure, Chart CG-49-1 be used to find the internal diameter. For additional information on Armstrong flash tanks, see page CRE-210.

**Figure CG-49-1. Flash Steam Recovery from an Air Heater Battery**

Flash is taken from the flash tank and combined with live steam, the pressure of which is reduced to that of the flash by a reducing valve.

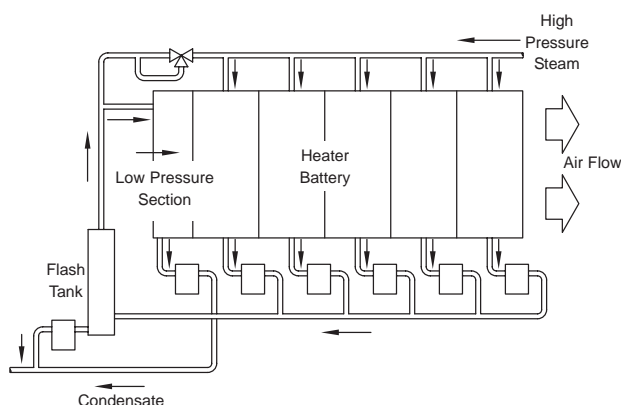

**Chart CG-49-1. Determination of Internal Diameter of Flash Tank to Handle a Given Quantity of Flash Steam**

Find amount of available flash steam (in kg/h) on bottom scale, read up to curve and across to vertical scale, to get diameter in mm.

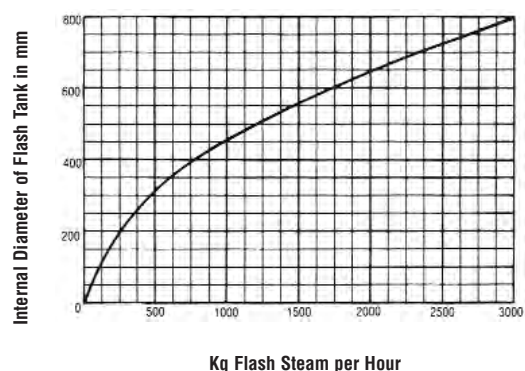



# How to Trap Absorption Machines

An absorption refrigeration machine chills water for air conditioning or process use by evaporating a water solution, usually lithium bromide. Steam provides the energy for the concentration part of the cycle and, except for electric pumps, is the only energy input during the entire cycle.

A steam trap installed on a steam absorption machine should handle large condensate loads and purge air at low pressure, modulated conditions.

### Trap Selection and Safety Factor

Determine the condensate load in kg/h produced by a low pressure (normally 1 barg or less) single-stage steam absorption machine by dividing its rating in kJ/h of refrigeration by 2 100 (the amount of steam in kg/h required to produce a ton of refrigeration). This represents the consumption at the rated capacity of the machine.

**EXAMPLE:** How much condensate will a single-stage steam absorption machine with a rated capacity of 2 512 000 kJ/h produce?

Divide the 2 512 000 kJ/h machine capacity rating by 2 100 to get the condensate load – 1 200 kg/h.

A 2:1 safety factor should be applied to the full capacity condensate load, and the steam trap must be capable of draining this load, at a 0,1 bar differential. In other words, the machine in the example would require a trap capable of handling 2 400 kg/h of condensate at 0,1 bar, and the capability of functioning at the maximum pressure differential, usually 1 bar.

In comparison, two-stage absorption machines operate at a higher steam pressure of 10 barg. They have an advantage over single-stage units in that their energy consumption per kJ of refrigeration is less.

**EXAMPLE:** How much condensate will a two-stage steam absorption machine with a rated capacity of 1 675 000 kJ/h produce?

Divide the 1 675 000 kJ/h machine capacity rating by 4 200 to get the condensate load - 400 kg/h.

On two-stage steam absorption machines, a 3:1 safety factor should be used. Therefore, the example requires a steam trap with a capacity of 1 200 kg/h. At pressures above 2 barg, the trap capacity must be achieved at 1/2 maximum pressure differential, which in the example is 5 bar. At pressures below 2 barg, the trap capacity must be achieved at 0,15 bar differential pressure. However, the trap must still be capable of operating at a maximum inlet pressure of 10 barg.

The F&T trap with an integral vacuum breaker is ideally suited for draining both single- and double-stage steam absorption machines. It provides an even, modulated condensate flow and energy-conserving operation. An inverted bucket trap with an external thermostatic air eliminator may also be acceptable.

### Installation

Mount the steam trap below the steam coil of the absorption machine with a drip leg height of at least 400 mm (Fig. CG-50-1). This ensures a minimum differential pressure across the trap of 0,1 bar. Whichever trap is used, a standby trapping system is recommended for this service. In the event that a component in the drainage system needs maintenance, the absorption machine can operate on the standby system while the repairs are being made. This ensures continuous, uninterrupted service.

In some cases, very heavy condensate loads may require the use of two traps operating in parallel to handle the normal load.

**Figure CG-50-1.** Generally approved method of piping steam absorption machine with standby trapping system.

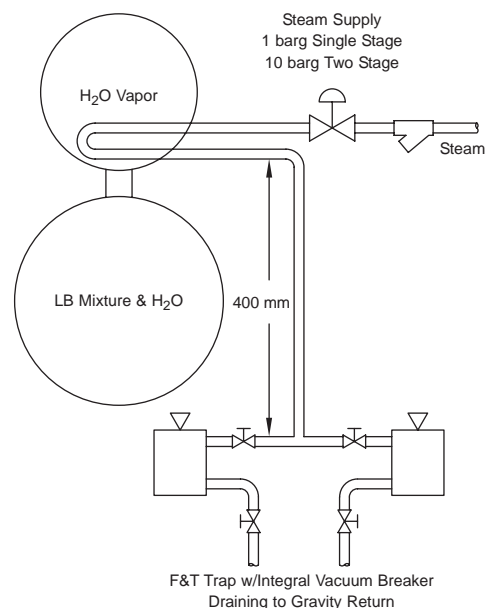

Table CG-50-1. Recommendation Chart (See Page CG-9 for "Feature Code" References.)		
Equipment Being Trapped	1st Choice and Feature Code	Alternate Choice
Steam Absorption Machine	F&T A, B, G	*IB

**Note:** Vacuum breaker and standby system should be provided.

\* With external thermostatic air vent.



# Trap Selection and Safety Factors

This table provides recommendations for traps likely to be most effective in various applications. The recommended safety factors ensure proper operation under varying conditions.

For more specific information on recommended traps and safety factors, contact your Armstrong Representative.

Table CG-51-1			
Application	1st Choice	2nd Choice	Safety Factor
<b>Boiler Header</b> (Superheat)	IBLV	F&T	1.5:1
	IBCV Burnished	Water	Star-Up Load
<b>Steam Mains &amp; Branch Lines</b> (Non-Freezing) (Freezing)	IB (CV if pressure varies)	F&T	2:1, 3:1 if at and of main ahead of valve, or on branch
	IB	Thermostatic or Disc	Same as above
<b>Steam Separator</b> Steam quality 90% or less	IBLV	DC	3:1
	DC	–	
<b>Trace Lines</b>	IB	Thermostatic or Disc	2:1
<b>Unit Heaters and air Handlers</b> (Content Pressure) (0 - 1 barg Variable Pressure) (1 - 2 barg Variable Pressure) (> 2 barg Variable Pressure)	IBLV	F&T	3:1
	F&T	IBLV	2:1 at 0,1 bar Differential
			2:1 at 0,2 bar Differential
			3:1 at 1/2 Max. Pressure Differential
<b>Finned Radiation &amp; Pipe Coils</b> (Constant Pressure) (Variable Pressure)	IB	Thermostatic	3:1 for quick heating 2:1 normally
	F&T	IB	
<b>Process Air Heaters</b> (Constant Pressure) (Variable Pressure)	IB	F&T	2:1
	F&T	IBLV	3:1 at 1/2 Max. Pressure Differ.
<b>Steam Absorption Machine (Chiller)</b>	F&T	IB Ext. Air Vent	2:1 at 0,1 bar Differential
<b>Shell &amp; Tube Heat Exchangers, Pipe &amp; Embossed Coils</b> (Constant Pressure) (Variable Pressure)	IB	DC or F&T	2:1
	F&T	DC or IBT (if > 2 barg IBLV)	< 1 barg 2:1 at 0,1 bar 1 - 2 barg 2:1 at 0,2 bar > 2 barg 3:1 at 1/2 Max. Pressure Differential
<b>Evaporator Single Effect &amp; Multiple Effect</b>	DC	IBLV or F&T	2:1, if load 25 000 kg/h use 3:1
<b>Jacketed Kettles</b> (Gravity Drain) (Syphon Drain)	IBLV	F&T or Thermostatic	3:1
	DC	IBLV	
<b>Rotating Dryers</b>	DC	IBLV	3:1 for DC, 8:1 for IB constant pressure, 10:1 for IB variable pressure
<b>Flash Tanks</b>	IBLV	DC or F&T	3:1

- IBLV = Inverted Bucket Large Vent
- IBCV = Inverted Bucket Internal Check Valve
- IBT = Inverted Bucket Thermic Vent
- F&T = Float & Thermostatic
- DC = Differential Condensate Controller

Use an IB with external air vent above the F&T pressure limitations or if the steam is dirty. All safety factors are at the operating pressure differential unless otherwise noted.



# Installation and Testing of Armstrong Steam Traps

Steam Conservation Guidelines

## Before Installing

Run pipe to trap. Before installing the trap, clean the line by blowing down with steam or compressed air. (Clean any strainer screens after this blowdown.)

## Trap Location ABCs

**A**ccessible for inspection and repair.

**B**elow drip point whenever possible.

**C**lose to drip point.

**Trap Hookups.** For typical hookups, see Figs. CG-52-1 (below) through CG-55-3, pages CG-52 through CG-55.

**Shutoff Valves** ahead of traps are needed when traps drain steam mains, large water heaters, etc., where system cannot be shut down for trap maintenance. They are not needed for small steam-heated machines – a laundry press, for example. Shutoff valve in steam supply to machine is usually sufficient.

**Shutoff Valves** in trap discharge line are needed when trap has a by-pass. It is a good idea when there is high pressure in discharge header. See also Check Valves.

**By-passes** (Figs. CG-53-3 and CG-53-4) are not recommended as, if left open, they will defeat the function of the trap. If continuous service is absolutely required, use two traps in parallel, one as a primary, one as a standby.

**Unions.** If only one is used, it should be on discharge side of trap. With two unions, avoid horizontal or vertical in-line installations. The best practice is to install at right angles as in Figs. CG-52-1 and CG-53-3, or parallel as in Fig. CG-53-4.

**Standard Connections.** Servicing is simplified by keeping lengths of inlet and outlet nipples identical for traps of a given size and type. A spare trap with identical fittings and half unions can be kept in storeroom. In the event a trap needs repair, it is a simple matter to break the two unions, remove the trap, put in the spare and tighten the unions. Repairs can then be made in the shop and the repaired trap, with fittings and half unions, put back in stock.

**Test Valves** (Fig. CG-52-1) provide an excellent means of checking trap operation. Use a small plug valve. Provide a check valve or shutoff valve in the discharge line to isolate trap while testing.

Figure CG-52-1. Typical IB Hookup

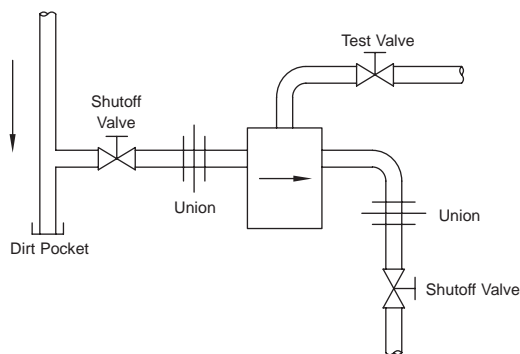
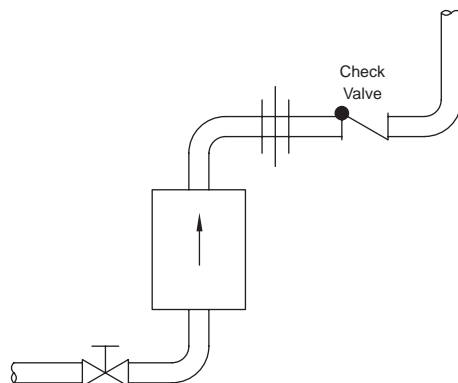

Figure CG-52-2. Typical IB Bottom Inlet – Top Outlet Hookup



# Installation and Testing of Armstrong Steam Traps



**Strainers.** Install strainers ahead of traps if specified or when dirt conditions warrant their use. Some types of traps are more susceptible to dirt problems than others – see Recommendation Chart on page CG-9.

Some traps have built-in strainers. When a strainer blowdown valve is used, shut off steam supply valve before opening strainer blowdown valve. Condensate in trap body will flash back through strainer screen for thorough cleaning. Open steam valve slowly.

**Dirt Pockets** are excellent for stopping scale and core sand, and eliminating erosion that can occur in elbows when dirt pockets are not provided. Clean periodically.

**Syphon Installations** require a water seal and, with the exception of the DC, a check valve in or before the trap. Syphon pipe should be one size smaller than nominal size of trap used but not less than DN15 pipe size.

**Elevating Condensate.** Do not oversize the vertical riser. In fact, one pipe size smaller than normal for the job will give excellent results.

**Check Valves** are frequently needed. They are a must if no discharge line shutoff valve is used. Fig. CG-53-2 shows three possible locations for external check valves – Armstrong inverted bucket traps are available with internal check valves, while disc traps act as their own check valve. Recommended locations are given in Fig. CG-53-2.

**Discharge Line Check Valves** prevent backflow and isolate trap when test valve is opened. Normally installed at location B, Fig. CG-53-2. When return line is elevated and trap is exposed to freezing conditions, install check valve at location A.

**Inlet Line Check Valves** prevent loss of seal if pressure should drop suddenly or if trap is above drip point in IB traps. Armstrong Stainless Steel Check Valve in trap body, location D, Fig. CG-53-2, is recommended. If swing check is used, install at location C.

Figure CG-53-1. Typical IB Bottom Inlet – Side Outlet Hookup

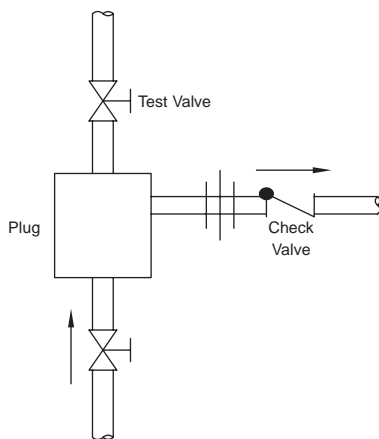

Figure CG-53-3. Typical IB By-pass Hookup

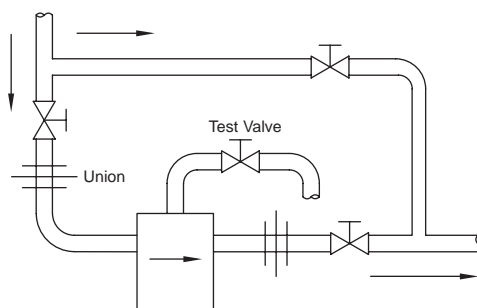

Figure CG-53-2. Possible Check Valve Locations

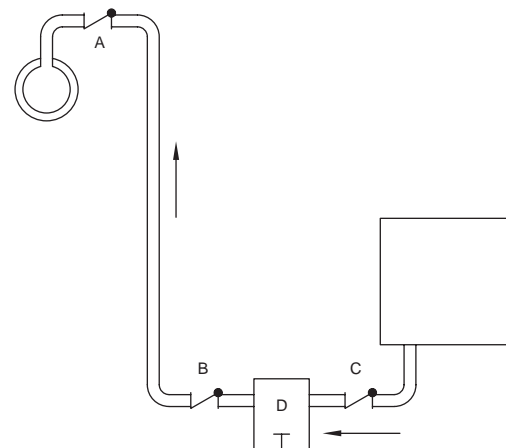
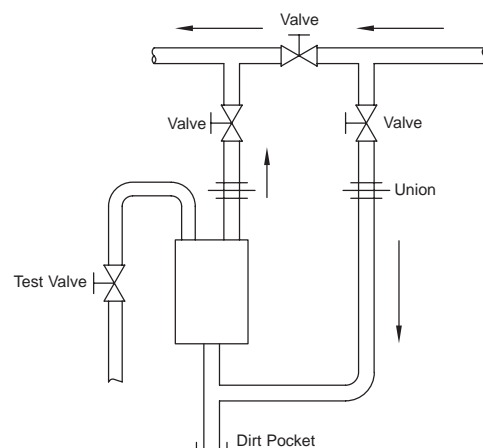

Figure CG-53-4. Typical IB By-pass Hookup, Bottom Inlet – Top Outlet





# Installation and Testing of Armstrong Steam Traps

A **Safety Drain Trap** should be used whenever there is a likelihood that the inlet pressure will fall below the outlet pressure of a primary steam trap, especially in the presence of freezing air. One such application would be on a modulated pressure heating coil that must be drained with an elevated return line. In the event of insufficient drainage from the primary trap, condensate rises into the safety drain and is discharged before it can enter the heat exchanger. An F&T trap makes a good safety drain because of its ability to handle large amounts of air and its simplicity of operation. Safety drain trap should be same size (capacity) as primary trap.

The proper application of a safety drain is shown in Fig. CG-54-1. The inlet to the safety drain must be located on the heat exchanger drip leg, above the inlet to the primary trap. It must discharge to an open sewer. The drain plug of the safety drain is piped to the inlet of the primary trap. This prevents the loss of condensate formed in the safety drain by body radiation when the primary trap is active. The safety drain has an integral vacuum breaker to maintain operation when pressure in the heat exchanger falls below atmospheric. The inlet of the vacuum breaker should be fitted with a gooseneck to prevent dirt from being sucked in when it operates. The vacuum breaker inlet should be provided with a riser equal in elevation to the bottom of the heat exchanger to prevent water leakage when the vacuum breaker is operating, but the drip leg and trap body are flooded.

## Protection Against Freezing

A properly selected and installed trap will not freeze as long as steam is coming to the trap. If the steam supply should be shut off, the steam condenses, forming a vacuum in the heat exchanger or tracer line. This prevents free drainage of the condensate from the system before freezing can occur. Therefore, install a vacuum breaker between the equipment being drained and the trap. If there is not gravity drainage through the trap to the return line, the trap and discharge line should be drained manually or automatically by means of a freeze protection drain. Also, when multiple traps are installed in a trap station, insulating the traps can provide freeze protection.

### Anti-Freeze Precautions.

1. Do not oversize trap.
2. Keep trap discharge lines very short.
3. Pitch trap discharge lines down for fast gravity discharge.
4. Insulate trap discharge lines and condensate return lines.
5. Where condensate return lines are exposed to ambient weather conditions, tracer lines should be considered.
6. If the return line is overhead, run vertical discharge line adjacent to drain line to top of return header and insulate drain line and trap discharge line together. See Fig. CG-54-2.

**NOTE:** A long horizontal discharge line invites trouble. Ice can form at the far end, eventually sealing off the pipe. This prevents the trap from operating. No more steam can enter the trap, and the water in the trap body freezes.

Figure CG-54-1. Typical Safety Drain Trap Hookup

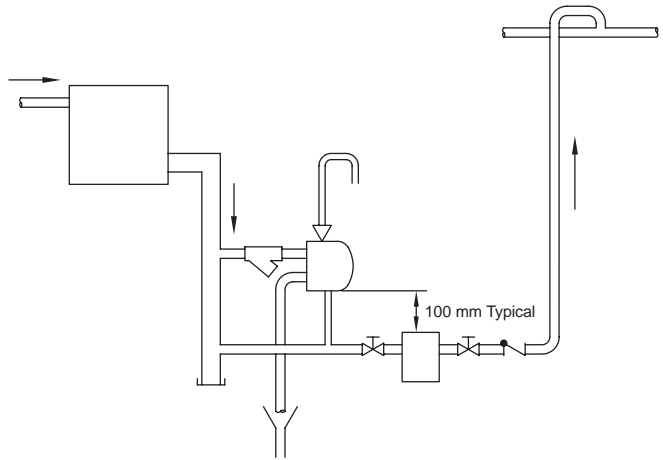
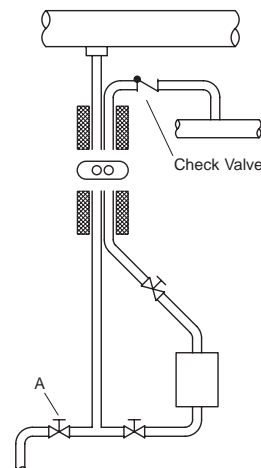
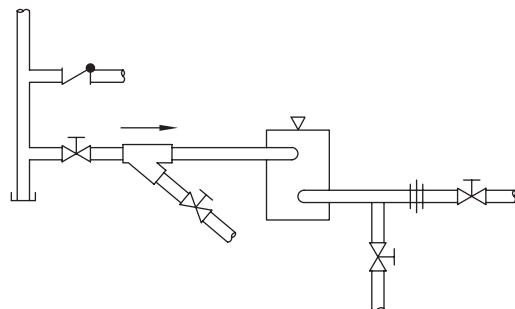

Figure CG-54-2.



Outdoor installation to permit ground level trap testing and maintenance when steam supply and return lines are high overhead. Drain line and trap discharge line are insulated together to prevent freezing. Note location of check valve in discharge line and blowdown valve **A** that drains the steam main when trap is opened for cleaning or repair.

Figure CG-54-3. Typical F&T Hookup



# Installation and Testing of Armstrong Steam Traps



## Testing Armstrong Steam Traps

### Testing Schedule.

For maximum trap life and steam economy, a regular schedule should be set up for trap testing and preventive maintenance. Trap size, operating pressure and importance determine how frequently traps should be checked.

Operating Pressure (barg)	Application			
	Drip	Tracer	Coil	Process
0 - 7	1	1	2	3
7 - 17	2	2	2	3
17 - 30	2	2	3	4
30 and above	3	3	4	12

### How to Test

The test valve method is best. Fig. CG-52-1 (page CG-52) shows correct hookup, with shutoff valve in return line to isolate trap from return header. Here is what to look for when test valve is opened:

1. **Condensate Discharge** – Inverted bucket and disc traps should have an intermittent condensate discharge. F&T traps should have a continuous condensate discharge, while thermostatic traps can be either continuous or intermittent, depending on the load. When an IB trap has an extremely small load it will have a continuous condensate discharge which causes a dribbling effect. This mode of operation is normal under this condition.
2. **Flash Steam** – Do not mistake this for a steam leak through the trap valve. Condensate under pressure holds more heat units – kilojoules (kJ) – per kilogram than condensate at atmospheric pressure. When condensate is discharged, these extra heat units re-evaporate some of the condensate. See description of flash steam on page CG-11 *How to Identify Flash*: Trap users sometimes confuse flash steam with leaking steam. Here's how to tell the difference: If steam blows out continuously, in a "blue" stream, it's leaking steam. If steam "floats" out intermittently (each time the trap discharges) in a whitish cloud, it's flash steam.
3. **Continuous Steam Blow** – Trouble. Refer to page CG-56.
4. **No Flow** – Possible trouble. Refer to page CG-56.

**Listening Device Test.** Use a listening device or hold one end of a steel rod against the trap cap and the other end against your ear. You should be able to hear the difference between the intermittent discharge of some traps and the continuous discharge of others. This correct operating condition can be distinguished from the higher velocity sound of a trap blowing through. Considerable experience is required for this method of testing, as other noises are telegraphed along the pipe lines.

**Pyrometer Method of Testing.** This method may not give accurate results, depending on the return line design and the diameter of the trap orifice. Also, when discharging into a common return, another trap may be blowing through, causing a high temperature at the outlet of the trap being tested. Better results can be obtained with a listening device. Request Armstrong Bulletin 310.

Figure CG-55-1. Typical DC Hookup

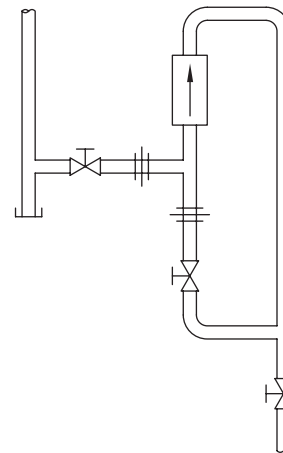

Figure CG-55-2. Typical Disc Trap Hookup

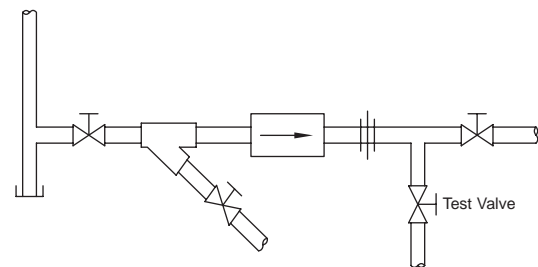
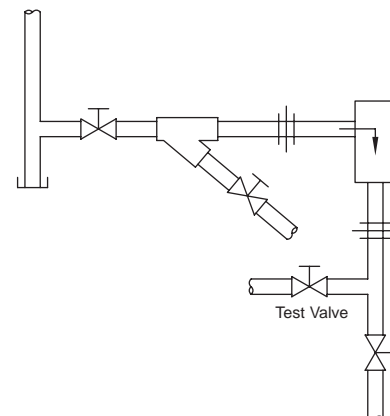

Figure CG-55-3. Typical Thermostatic Hookup







# Troubleshooting Armstrong Steam Traps

The following summary will prove helpful in locating and correcting nearly all steam trap troubles. Many of these are actually system problems rather than trap troubles.

More detailed troubleshooting literature is available for specific products and applications – consult factory.

Whenever a trap fails to operate and the reason is not readily apparent, the discharge from the trap should be observed. If the trap is installed with a test outlet, this will be a simple matter – otherwise, it will be necessary to break the discharge connection.

## Cold Trap – No Discharge

If the trap fails to discharge condensate, then:

- A.** Pressure may be too high.
  - 1. Wrong pressure originally specified.
  - 2. Pressure raised without installing smaller orifice.
  - 3. PRV out of order.
  - 4. Pressure gauge in boiler reads low.
  - 5. Orifice enlarged by normal wear.
  - 6. High vacuum in return line increases pressure differential beyond which trap may operate.
- B.** No condensate or steam coming to trap.
  - 1. Stopped by plugged strainer ahead of trap.
  - 2. Broken valve in line to trap.
  - 3. Pipe line or elbows plugged.
- C.** Worn or defective mechanism.  
Repair or replace as required.
- D.** Trap body filled with dirt.  
Install strainer or remove dirt at source.
- E.** For IB, bucket vent filled with dirt. Prevent by:
  - 1. Installing strainer.
  - 2. Enlarging vent slightly.
  - 3. Using bucket vent scrubbing wire.
- F.** For F&T traps, if air vent is not functioning properly, trap will likely air bind.
- G.** For thermostatic traps, the bellows element may rupture from hydraulic shock, causing the trap to fail closed.
- H.** For disc traps, trap may be installed backward.

## Hot Trap – No Discharge

- A.** No condensate coming to trap.
  - 1. Trap installed above leaky by-pass valve.
  - 2. Broken or damaged syphon pipe in syphon drained cylinder.
  - 3. Vacuum in water heater coils may prevent drainage.  
Install a vacuum breaker between the heat exchanger and the trap.

## Steam Loss

If the trap blows live steam, the trouble may be due to any of the following causes:

- A.** Valve may fail to seat.
  - 1. Piece of scale lodged in orifice.
  - 2. Worn parts.
- B.** IB trap may lose its prime.
  - 1. If the trap is blowing live steam, close the inlet valve for a few minutes. Then gradually open. If the trap catches its prime, chances are the trap is all right.
  - 2. Prime loss is usually due to sudden or frequent drops in steam pressure. On such jobs, the installation of a check valve is called for – location D or C in Fig. CG-53-2 (page CG-53). If possible, locate trap well below drip point.
- C.** For F&T and thermostatic traps, thermostatic elements may fail to close.

## Continuous Flow

If an IB or disc trap discharges continuously, or an F&T or thermostatic trap discharges at full capacity, check the following:

- A.** Trap too small.
  - 1. A larger trap, or additional traps, should be installed in parallel.
  - 2. High pressure traps may have been used for a low pressure job. Install right size of internal mechanism.
- B.** Abnormal water conditions. Boiler may foam or prime, throwing large quantities of water into steam lines. A separator should be installed or else the feed water conditions should be remedied.

## Sluggish Heating

When trap operates satisfactorily, but unit fails to heat properly:

- A.** One or more units may be short-circuiting. The remedy is to install a trap on each unit. See page CG-22.
- B.** Traps may be too small for job even though they may appear to be handling the condensate efficiently. Try next larger size trap.
- C.** Trap may have insufficient air-handling capacity, or the air may not be reaching trap. In either case, use auxiliary air vents.

## Mysterious Trouble

If trap operates satisfactorily when discharging to atmosphere, but trouble is encountered when connected with return line, check the following:

- A.** Back pressure may reduce capacity of trap.
  - 1. Return line too small – trap hot.
  - 2. Other traps may be blowing steam – trap hot.
  - 3. Atmospheric vent in condensate receiver may be plugged – trap hot or cold.
  - 4. Obstruction in return line – trap hot.
  - 5. Excess vacuum in return line – trap cold.

## Imaginary Troubles

If it appears that steam escapes every time trap discharges, remember: Hot condensate forms flash steam when released to lower pressure, but it usually condenses quickly in the return line. See Chart CG-11-1 on page CG-11.

# Pipe Sizing Steam Supply and Condensate Return Lines



## Definitions

**Steam mains or mains** carry steam from the boiler to an area in which multiple steam-using units are installed.

**Steam branch lines** take steam from steam main to steam-heated unit.

**Trap discharge lines** move condensate and flash steam from the trap to a return line.

**Condensate return lines** receive condensate from many trap discharge lines and carry the condensate back to the boiler room.

## Pipe Sizing

Two principal factors determine pipe sizing in a steam system:

1. The initial pressure at the boiler and the allowable pressure drop of the total system. The total pressure drop in the system should not exceed 20% of the total maximum pressure at the boiler. This includes all drops - line loss, elbows, valves, etc. Remember, pressure drops are a loss of energy.
2. Steam velocity. Erosion and noise increase with velocity. Reasonable velocities for process steam are 30 to 60 m/sec, but lower pressure heating systems normally have lower velocities. Another consideration is future expansion. Size your lines for the foreseeable future. If ever in doubt, you will have less trouble with oversized lines than with ones that are marginal.

**EXAMPLE:** What is the maximum load capacity of a steam line with a pressure of 4 bar and a diameter of 50 mm? Reading down the left hand column of Table CG-58-1 "Steam Pressure in barg" to 4 and then to the direct right to the column for a steam pipe 50 mm in diameter, it is determined that the pipe will handle 505 kg/h of steam.

**Table CG-57-2. Steam Velocity in m/sec**

Pipe Diameter		Steam Pressure in barg			
Inch	mm	1	12	25	100
1/2"	15	17	33	37	50
2"	50	19	38	44	50
4"	100	21	41	47	50
6"	150	22	44	50	50

To determine the capacities of superheated steam use the multiplier correction factors in Table CG-57-3.

**Table CG-57-1. Inside and Outside Pipe Diameters According to DIN 2448**

Pipe Connection Size (In.)	Pipe Connection DN	Outside Diameter in mm	Wall Thickness in mm	Inside Diameter in mm
1/2"	15	21,3	2,0	17,3
3/4"	20	26,9	2,3	22,3
1"	25	33,7	2,6	28,5
1 1/4"	32	42,4	2,6	37,2
1 1/2"	40	48,3	2,6	43,1
2"	50	60,3	2,9	60,1
2 1/2"	65	76,1	2,9	70,3
3"	80	88,9	3,2	82,5
4"	100	114,3	3,6	107,1
5"	125	139,7	4,0	131,7
6"	150	168,3	4,5	159,3
8"	200	209,1	5,9	207,3
10"	250	273,0	6,3	260,4

**Table CG-57-3. Capacity Factors for Superheated Steam**

Pipe Size 32							
Steam Temperature		250°	300°	350°	400°	450°	500°
Pressure barg	1	1,06	1,02	1,04	1,04	1,05	1,06
	3	1,11	1,17	1,17	1,17	1,17	1,15
	8	1,20	1,14	1,09	1,06	1,06	1,06
	12	1,20	1,14	1,09	1,06	1,06	1,04
	20	1,27	1,19	1,11	1,06	1,06	1,03
	40	-	1,30	1,17	1,10	1,04	1,00
	100	-	-	1,52	1,17	1,06	0,98
Pipe Size 100							
Steam Temperature		250°	300°	350°	400°	450°	500°
Pressure barg	1	1,10	1,08	1,12	1,13	1,13	1,15
	3	1,30	1,08	1,00	1,11	1,30	1,30
	8	1,15	1,09	1,08	1,10	1,09	1,10
	12	1,18	1,15	1,09	1,09	1,10	1,09
	20	1,28	1,19	1,11	1,09	1,09	1,08
	40	-	1,25	1,14	1,11	1,05	1,02
	100	-	-	1,47	1,14	1,06	0,97
Pipe Size 200							
Steam Temperature		250°	300°	350°	400°	450°	510°
Pressure barg	1	1,18	1,19	1,20	1,20	1,19	1,30
	3	1,20	1,20	1,20	1,17	1,16	1,16
	8	1,26	1,23	1,18	1,14	1,12	1,12
	12	1,28	1,23	1,16	1,11	1,10	1,09
	20	1,29	1,21	1,13	1,04	1,06	1,05
	40	-	1,23	1,13	1,06	1,00	1,00
	100	-	-	1,40	1,01	0,98	0,95



# Pipe Sizing Steam Supply and Condensate Return Lines

Table CG-58-1 can also be used to determine the pressure necessary to handle a known quantity of steam. If a 80 mm steam pipe must handle 4 100 kg/h of steam, how much pressure will be needed? Reading down the column for a steam pipe measuring DN80 until the figure 4 100 is reached and then directly to the left, it is determined that a steam pressure of 16 barg will be necessary to handle the load.

For quick steam velocity determination, see Table CG-57-2. For an exact measurement, the following formula may be used:

$$V = \frac{Q}{3\,600 \times S}$$

**Where:**

- V = Velocity in m/sec
  - Q = Steam load in m<sup>3</sup>/h
  - S = Inside area of pipe in m<sup>2</sup> (see Table CG-57-1).
- When necessary we can find the pressure drop in a steam line by using Chart CG-59-1.

**EXAMPLE:** How much of a pressure drop will be present in a straight steam line DN80, 150 m in length with a load of 2 000 kg/h and a pressure of 6 barg, and what will be the pressure at the end of the line?

Assume an average pressure in the line of 5,5 barg. From the tables we find a pressure drop of 38 mm WC/m so the total pressure drop will be 150 x 38 = 5 700 mm WC/m ≈ 0,57 bar. Pressure at the end of the main will then be 6 - 0,57 = 5,43 barg.

**Trap Discharge Lines**

Trap discharge lines are usually short. Assuming the trap is properly sized for the job, use a trap discharge line the same size as the trap connections. At very low pressure differential between trap and condensate return pipe, trap discharge lines can be increased one pipe size advantageously.

**Condensate Return Lines**

For medium and large-sized plants, the services of a consultant should be employed to engineer the condensate return pipe or pipes. Usually it is considered good practice to select return pipe one or two sizes larger to allow for 1) increase in plant capacity and 2) eventual fouling of pipe with rust and scale.

**EXAMPLE:** What is the pressure drop in a DN40 condensate return line with a capacity of 400 kg/h, when the steam pressure is 2 barg and the condensate return line to atmosphere of 150 m length?

From Table CG-59-1 take the capacity factor corresponding to 2 barg = 0,256 and then divide the given load by this factor:

$$\frac{400}{0,256} = 1\,562 \text{ kg/h.}$$

This is corresponding to a pressure drop of about 2 mm WC/m in a DN 40 pipe. If the condensate line is 150 m long, the total pressure drop is 150 x 2 = 300 mm WC (0,3 barg).

**Traps and High Back Pressure**

Back pressures excessive by normal standards may occur due to fouling of return lines, increase in condensate load or faulty trap operation. Depending on the operation of the particular trap, back pressure may or may not be a problem. See line "I" in Recommendation Chart on page CG-9. If a back pressure is likely to exist in the return lines, be certain the trap selected will work against it.

Back pressure does lower the pressure differential and, hence, the capacity of the trap is decreased. In severe cases, the reduction in capacity could make it necessary to use traps one size larger to compensate for the decrease in operating pressure differential.

**Table CG-58-1. Capacity Chart in kg/h for Steam Lines (Velocity 30 m/sec)**

Steam Pressure in bar(a)	STEAM PIPE DIAMETER										
	15	20	25	32	40	50	65	80	100	125	150
1,1	14	24	39	67	92	150	215	330	575	900	1 300
1,3	16	28	45	79	105	175	250	390	670	1 050	1 520
1,5	18	32	52	90	125	200	290	445	765	1 205	1 735
2	24	42	68	120	160	265	375	580	1 000	1 575	2 275
3	35	62	99	170	235	385	550	850	1 465	2 300	3 325
4	46	81	130	225	310	505	720	1 115	1 920	3 015	4 355
5	56	99	160	280	380	625	890	1 375	2 365	3 720	5 375
6	67	120	190	330	450	740	1 055	1 630	2 810	4 420	6 385
8	88	155	250	435	590	970	1 385	2 145	3 690	5 800	8 380
9	98	175	280	485	660	1 090	1 550	2 400	4 130	6 490	9 375
10	110	190	310	535	730	1 200	1 715	2 650	4 565	7 175	10 360
12	130	230	370	640	870	1 430	2 040	3 155	5 435	8 540	12 340
14	150	265	430	740	1 010	1 660	2 370	3 660	6 305	9 910	14 310
16	170	300	490	845	1 150	1 890	2 695	4 165	7 170	11 270	16 280
18	190	340	545	945	1 290	2 120	3 020	4 670	8 040	12 640	18 260
20	210	375	605	1 050	1 430	2 345	3 350	5 175	8 915	14 010	20 240
22	230	410	665	1 150	1 570	2 575	3 675	5 680	9 785	15 380	22 220
26	275	485	785	1 360	1 850	3 040	4 335	6 700	11 540	18 140	26 200
30	315	560	905	1 565	2 135	3 505	5 000	7 730	13 310	20 920	30 220
40	425	750	1 210	2 100	2 860	4 695	6 700	10 350	17 830	28 020	40 480
50	535	945	1 525	2 645	3 605	5 925	8 450	13 060	22 500	35 360	51 070
60	650	1 150	1 855	3 220	4 385	7 200	10 270	15 880	27 340	42 970	62 080
70	770	1 360	2 200	3 815	5 195	8 535	12 180	18 820	32 410	50 940	73 580
80	895	1 585	2 560	4 435	6 040	9 930	14 160	21 890	37 700	59 250	85 580
90	1 030	1 820	2 935	5 090	6 935	11 400	16 260	25 120	43 270	68 000	98 230
100	1 170	2 065	3 335	5 785	7 880	12 950	18 470	28 550	49 170	77 280	111 630

# How to Size Condensate Return Lines



**Table CG-59-1. Capacity Chart for Condensate Lines**

Pressure drop in mm WC per running m pipe	Pipe Diameter in mm										
	15	20	25	32	40	50	65	80	100	125	150
	Capacity of Condensate in kg/h										
1	67	153	310	677	1 048	2 149	3 597	6 413	13 527	25 410	40 485
2	95	217	438	958	1 483	3 040	5 087	9 070	19 130	35 935	57 255
3	116	266	537	1 174	1 816	3 723	6 230	11 108	23 430	44 012	70 123
4	134	307	620	1 355	2 097	4 299	7 194	12 827	27 055	50 821	80 971
5	150	343	693	1 516	2 345	4 807	8 044	14 341	30 248	56 819	90 529
6	164	376	759	1 660	2 569	5 265	8 811	15 710	33 135	62 242	99 169
7	177	406	820	1 793	2 775	5 687	9 517	16 968	35 790	67 230	107 115
8	190	434	877	1 917	2 966	6 080	10 175	18 140	38 261	71 871	114 511
9	201	461	930	2 033	3 146	6 449	10 792	19 240	40 582	76 231	121 457
10	212	486	980	2 143	3 317	6 798	11 375	20 281	42 777	80 355	128 027
12	232	532	1 074	2 348	3 633	7 447	12 461	22 217	46 860	88 024	140 247
14	251	575	1 160	2 536	3 924	8 043	13 460	23 997	50 615	95 077	151 484
16	268	615	1 240	2 711	4 195	8 599	14 389	25 654	54 110	101 642	161 943
18	285	652	1 315	2 876	4 450	9 120	15 262	27 210	57 392	107 807	171 767
20	300	687	1 387	3 032	4 691	9 614	16 088	28 682	60 496	113 639	181 058
22	315	721	1 454	3 180	4 920	10 083	16 873	30 082	63 449	119 186	189 896
24	329	753	1 519	3 321	5 138	10 531	17 623	31 420	66 270	124 485	198 339
26	342	784	1 581	3 457	5 348	10 961	18 343	32 720	68 976	129 568	206 438
28	355	813	1 641	3 587	5 550	11 375	19 035	33 937	71 580	134 460	214 231
30	368	842	1 698	3 713	5 745	11 774	19 703	35 128	74 093	139 179	221 750
32	380	869	1 754	3 835	5 933	12 160	20 350	36 280	76 523	143 743	229 023
34	392	896	1 808	3 953	6 116	12 535	20 976	37 397	78 878	148 167	236 071
36	403	922	1 861	4 067	6 293	12 898	21 584	38 481	81 165	152 463	242 915
38	414	947	1 912	4 179	6 466	13 252	22 175	39 535	83 389	156 641	249 572
40	425	972	1 961	4 287	6 634	13 596	22 751	40 563	85 555	160 710	256 055
42	435	996	2 010	4 393	6 798	13 932	23 313	41 564	87 668	164 679	262 379
44	446	1 020	2 057	4 497	6 958	14 260	23 862	42 542	89 731	168 554	268 553
46	456	1 042	2 103	4 598	7 114	14 580	24 398	43 499	91 747	172 342	274 589
48	465	1 065	2 148	4 697	7 267	14 894	24 923	44 434	93 721	176 049	280 494
50	475	1 087	2 193	4 794	7 417	15 201	25 437	45 350	95 653	179 679	286 279

Capacity of flashing condensate in kg/h in a condensate return at atmospheric pressure. The above capacities have been calculated with primary pressure = 0,35 barg.

For other pressures multiply the above capacities by the following factors:

- 1 barg: 0,415
- 2 barg: 0,256
- 4 barg: 0,162
- 7 barg: 0,124
- 9 barg: 0,108
- 12 barg: 0,09
- 17 barg: 0,07
- 31 barg: 0,06
- 42 barg: 0,055

**Chart CG-59-1. Pressure Drop in Saturated Steam Lines**

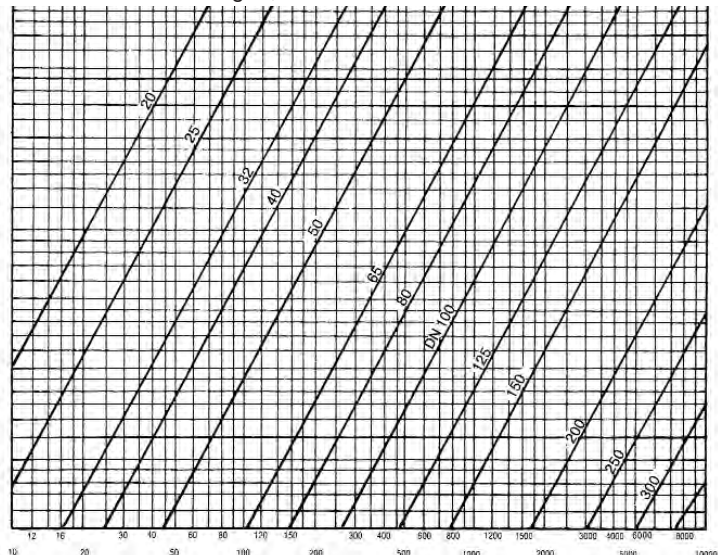
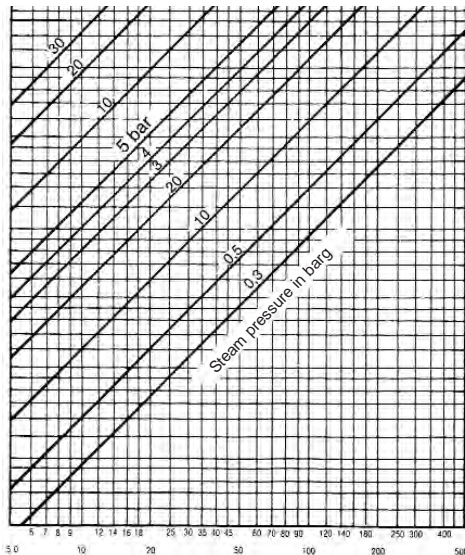

Pressure drop of Steam in mm WC/m

Quantity of Steam in kg/h



# Specific Heat – Specific Gravity

Steam Conservation Guidelines

Table CG-60-1. Physical Properties of Liquids and Solids							
	Liquid (L) or Solid (S)	sp. gr. @ 18-20°C	sp. ht. @ 20°C kJ/kg/°C		Liquid (L) or Solid (S)	sp. gr. @ 18-20°C	sp. ht. @ 20°C kJ/kg/°C
Acetic acid 100%	L	1,05	2,01	Nickel	S	8,90	0,46
Acetic acid 100%	L	1,01	4,02	<b>Nitric acid, 95%</b>	L	<b>1,50</b>	<b>2,09</b>
<b>Acetone, 100%</b>	L	<b>0,78</b>	<b>2,152</b>	Nitric acid, 60%	L	1,37	2,68
Alcohol, ethyl, 95%	L	0,81	2,51	Nitric acid, 10%	L	1,05	3,77
Alcohol, methyl, 90%	L	0,82	2,72	<b>No.1 Fuel Oil (kerosene)</b>	L	<b>0,81</b>	<b>1,97</b>
<b>Aluminium</b>	S	<b>2,64</b>	<b>0,96</b>	No.2 Fuel Oil	L	0,86	1,84
Ammonia, 100%	L	0,61	4,61	No.3 Fuel Oil	L	0,88	1,80
Ammonia, 26%	L	0,90	4,19	<b>No.4 Fuel Oil</b>	L	<b>0,90</b>	<b>1,76</b>
<b>Aroclor</b>	L	<b>1,44</b>	<b>1,17</b>	No.5 Fuel Oil	L	0,93	1,72
Asbestos board	S	0,88	0,80	No.6 Fuel Oil	L	0,95	1,67
Asphalt	L	1,00	1,76	API Mid-continent crude	L	0,085	1,84
<b>Asphalt, solid</b>	S	<b>1,1 - 1,5</b>	<b>0,92 - 1,7</b>	API gas oil	L	0,88	1,76
Benzene	L	0,84	1,72	<b>Paper</b>	S	<b>1,7 - 1,15</b>	<b>1,88</b>
Brickwork & Masonry	S	1,6 - 2,0	0,92	Paraffin	S	0,86 - 0,9	2,60
<b>Brine - calcium chloride, 25%</b>	L	<b>1,23</b>	<b>2,885</b>	Paraffin, melted	L	0,90	2,89
Brine - sodium chloride, 25%	L	1,19	3,291	<b>Phenol (carbolic acid)</b>	L	<b>1,07</b>	<b>2,34</b>
Clay, dry	S	1,9 - 2,4	0,938	Phosphoric acid, 20%	L	1,11	3,56
<b>Coal</b>	S	<b>1,2 - 1,8</b>	<b>1,09 - 1,5</b>	Phosphoric acid, 10%	L	1,05	3,89
Coal tars	S	1,20	1,5@40°C	<b>Phthalic anhydride</b>	L	<b>1,53</b>	<b>0,971</b>
Coke, solid	S	1,0 - 1,4	1,11	Rubber, vulcanized	S	1,10	1,738
<b>Copper</b>	S	<b>8,82</b>	<b>0,42</b>	SAE - SW (#8 machine lube oil)	L	0,88	
Cork	S	0,25	2,01	<b>SAE - 20 (#20 machine lube oil)</b>	L	<b>0,89</b>	
Cotton, cloth	S	1,50	1,34	SAE - 30 (#30 machine lube oil)	L	0,89	
<b>Cottonseed oil</b>	L	<b>0,95</b>	<b>1,97</b>	Sand	S	1,4 - 1,76	0,795
Downtherm A	L	0,99	2,64	<b>Sea water</b>	L	<b>1,03</b>	<b>3,94</b>
Downtherm C	L	1,10	1,47 - 2,7	Silk	S	1,25 - 1,4	1,38
<b>Ethylene glycol</b>	L	<b>1,11</b>	<b>2,43</b>	Sodium hydroxide, 50% (caustic acid)	L	1,53	3,27
Fatty acid - palmitic	L	0,85	2,734	<b>Sodium hydroxide, 30%</b>	L	<b>1,33</b>	<b>3,52</b>
Fatty acid - stearic	L	0,84	2,303	Soybean oil	L	0,92	1,0 - 1,38
<b>Fish, fresh, average</b>	S		<b>3,14 - 3,4</b>	Steel, mild @ 21°C	S	7,90	0,46
Fruit, fresh, average	S		3,35 - 3,7	<b>Steel, stainless, 300 series</b>	S	<b>8,04</b>	<b>0,50</b>
Gasoline	L	0,73	2,22	Sucrose, 60% sugar syrup	L	1,29	3,10
<b>Glass, Pyrex</b>	S	<b>2,25</b>	<b>0,84</b>	Sucrose, 40% sugar syrup	L	1,18	2,76
Glass, wool	S	0,072	0,657	<b>Sugar, cane &amp; beet</b>	S	<b>1,66</b>	<b>1,26</b>
Glue, 2 parts water 1 part dry glue	L	1,09	3,73	Sulfur	S	2,00	0,85
<b>Glycerol, 100% (glycerin)</b>	L	<b>1,26</b>	<b>2,43</b>	Sulfuric acid, 110% (fuming)	L		1,13
Honey	L		1,42	<b>Sulfuric acid, 98%</b>	L	<b>1,84</b>	<b>1,47</b>
Hydrochloric acid, 31,5% (muriatic)	L	1,15	2,51	Sulfuric acid, 60%	L	1,50	2,18
<b>Hydrochloric acid, 10% (muriatic)</b>	L	<b>1,05</b>	<b>3,14</b>	Sulfuric acid, 20%	L	1,14	3,52
Ice	S	0,90	2,09	<b>Titanium (commercial)</b>	S	<b>4,50</b>	<b>0,54</b>
Ice cream	S		2,93	Toluene	L	0,86	1,76
<b>Lard</b>	S	<b>0,92</b>	<b>2,68</b>	Trichloroethylene	L	1,62	0,90
Lead	S	11,34	0,13	<b>Tetrachloride carbon</b>	L	<b>1,58</b>	<b>0,88</b>
Leather	S	0,86 - 1,0	1,51	Turpentine, spirits of	L	0,86	1,76
<b>Linseed oil</b>	L	<b>0,93</b>	<b>1,84</b>	Vegetables, fresh, average	S		3,06 - 3,9
Magnesia, 85%	L	0,208	1,13	<b>Water</b>	L	<b>1,00</b>	<b>4,19</b>
Maple syrup	L		2,01	Wines, table, dessert, average	L	1,03	3,77
<b>Meat, fresh, average</b>	S		<b>3,266</b>	Woods, vary from	S	0,35 - 0,9	3,77
Milk	L	1,03	3,77 - 3,9	<b>Wool</b>	S	<b>1,32</b>	<b>1,361</b>
				Zinc	S	7,05	0,398

Table CG-60-2. Physical Properties of Gases						
	sp. gr. @ 18-20°C	sp. ht. @ 20°C kJ/kg/°C		sp. gr. @ 18-20°C	sp. ht. @ 20°C kJ/kg/°C	
Air	1,00	1,00	Freon - 12		0,67	
Ammonia	0,60	2,26	Hydrogen	0,069	14,32	
<b>Benzene</b>		<b>1,361</b>	<b>Hydrogen sulfide</b>	<b>1,20</b>	<b>1,05</b>	
Butane	2,00	1,905	Methane	0,55	2,51	
Carbon dioxide	1,50	0,88	Nitrogen	0,97	1,059	
<b>Carbon monoxide</b>	<b>0,97</b>	<b>1,068</b>	<b>Oxygen</b>	<b>1,10</b>	<b>0,942</b>	
Chlorine	2,50	0,494	Propane	1,50	1,93	
Ethane	1,10	2,09	Sulfur dioxide		0,678	
<b>Ethylene</b>	<b>0,97</b>	<b>1,88</b>	Water vapor (steam)	2,30	1,897	

**Table CG-61-1. Pipe According to DIN 2440**

Diameter (Inches)	mm	Outside Diameter mm	Wall Thickness mm	Weight kg/m
1/8"	6	10,2	2,00	0,407
1/4"	8	13,5	2,35	0,650
3/8"	10	17,2	2,35	0,852
1/2"	15	21,3	2,65	1,22
3/4"	20	26,9	2,65	1,58
1"	25	33,7	3,25	2,44
1 1/4"	32	42,4	3,25	3,14
1 1/2"	40	48,3	3,25	3,61
2"	50	60,3	3,65	5,10
2 1/2"	65	76,1	3,65	6,51
3"	80	88,9	4,05	8,47
4"	100	114,3	4,50	12,1
5"	125	139,7	4,85	16,2
6"	150	165,1	4,85	19,2

**Table CG-61-2. Pipe According to DIN 2441**

Diameter (Inches)	mm	Outside Diameter mm	Wall Thickness mm	Weight kg/m
1/8"	6	10,2	2,65	0,493
1/4"	8	13,5	2,90	0,769
3/8"	10	17,2	2,90	1,02
1/2"	15	21,3	3,25	1,45
3/4"	20	26,9	3,25	1,90
1"	25	33,7	4,05	2,97
1 1/4"	32	42,4	4,05	3,84
1 1/2"	40	48,3	4,05	4,43
2"	50	60,3	4,50	6,17
2 1/2"	65	76,1	4,50	7,90
3"	80	88,9	4,85	10,1
4"	100	114,3	5,40	14,4
5"	125	139,7	5,40	17,8
6"	150	165,1	5,40	21,2

**Table CG-61-3. Pipe According to DIN**

Diameter (Inches)	mm	Outside Diameter mm	Wall Thickness mm	Weight kg/m
1/8"	6	10,2	1,6	0,344
1/4"	8	13,5	1,8	0,522
3/8"	10	17,2	1,8	0,688
1/2"	15	21,3	2,0	0,962
3/4"	20	26,9	2,3	1,41
1"	25	33,7	2,6	2,01
1 1/4"	32	42,4	2,6	2,57
1 1/2"	40	48,3	2,6	2,95
2"	50	60,3	2,9	4,14
2 1/2"	65	76,1	2,9	5,28
3"	80	88,9	3,2	6,81
4"	100	114,3	3,6	9,90
5"	125	139,7	4,0	13,5
6"	150	168,3	4,5	18,1

**Table CG-61-4. Flange Dimension According to DIN**

DN	PN 6				PN 10				PN 16				PN 25				PN 40			
	D	k	z	M	D	k	z	M	D	k	z	M	D	k	z	M	D	k	z	M
25	100	75	4	10	115	85	4	12	115	85	4	12	115	85	4	12	115	85	4	12
32	120	90	4	12	140	100	4	16	140	100	4	16	140	100	4	16	140	100	4	16
40	130	100	4	12	150	110	4	16	150	110	4	16	150	110	4	16	150	110	4	16
50	140	110	4	12	165	125	4	16	165	125	4	16	165	125	4	16	165	125	4	16
65	160	130	4	12	185	145	4	16	185	145	4	16	185	145	8	16	185	145	8	16
80	190	150	4	16	200	160	8	16	200	160	8	16	200	160	8	16	200	160	8	16
100	210	170	4	16	220	180	8	16	220	180	8	16	235	190	8	20	235	190	8	20
125	240	200	8	16	250	210	8	16	250	210	8	16	270	220	8	24	270	220	8	24
150	265	225	8	16	285	240	8	20	285	240	8	20	300	250	8	24	300	250	8	24
200	320	280	8	16	340	295	8	20	340	295	12	20	360	310	12	24	375	320	12	27
250	375	335	12	16	395	350	12	20	405	355	12	24	425	370	12	27	450	385	12	30
300	440	395	12	20	445	400	12	20	460	410	12	24	485	430	16	27	515	450	16	30

## Conversion Factors Metric to Anglo-American Units

### LENGTH

1 mm = 0,0394 inch  
1 m = 3,28 feet

1 inch = 25,4 mm  
1 foot = 0,305 m

### SURFACE

1 cm<sup>2</sup> = 0,155 sq. inch  
1 m<sup>2</sup> = 10,764 sq. feet

1 sq. inch = 6,45 cm<sup>2</sup>  
1 sq. foot = 0,0929 cm<sup>2</sup>

### VOLUME

1 dm<sup>3</sup> = 61,02 cu. inch  
1 m<sup>3</sup> = 35,31 cu. feet

1 cu. inch = 16,39 cm<sup>3</sup>  
1 cu. foot = 28,32 dm<sup>3</sup>

### VELOCITY

1 m/sec = 3,281 feet/sec

1 foot/sec = 0.305 m/s

### MASS

1 kg = 2,205 pound (lb.)

1 pound (lb.) = 0,452 kg

### PRESSURE

1 kg/cm<sup>2</sup> = 14,22 psi  
1 kg/m<sup>2</sup> = 0,205 psf  
1 bar = 14,5 psi  
1 psi = 0,0689 bar

### HEAT

1 kJ = 1 000 Joules  
1 kilowatt-hour (KWh) = 3 600 kJ  
1 Btu/Ft<sup>2</sup>.h.°F = 20,44 kJ/h.m<sup>2</sup>.°C

### TEMPERATURE

$\Delta t_c = 5/9 \Delta t_f$   
 $t_c = 5/9 (t_f - 32)$   
 $\Delta t_f = 9/5 \Delta t_c$   
 $t_f = 9/5 t_c + 32$

