

# RAC<sup>®</sup>

## BONETTI<sup>®</sup>

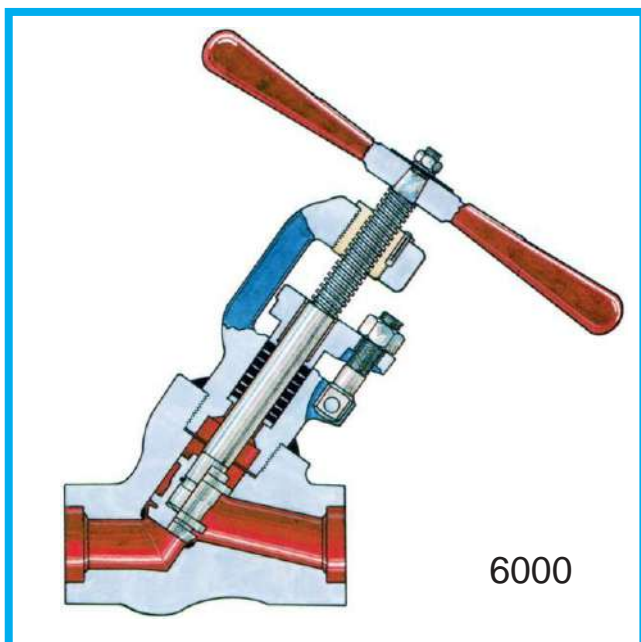

### BONT

**Forged Steel Valves  
Type WBY  
Welded Bonnet  
ASME Class  
600 - 900 - 1700  
2700 - 4500**

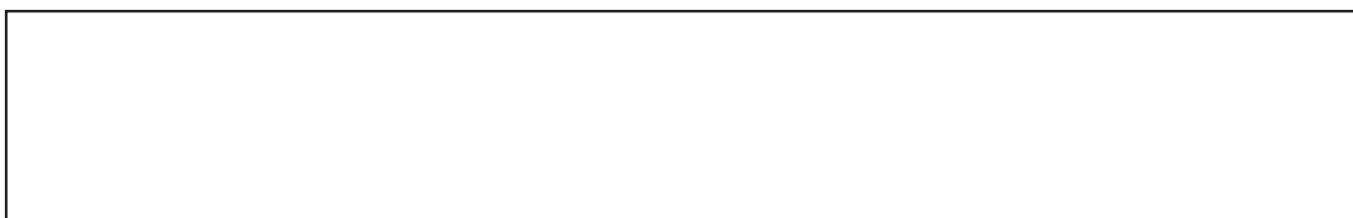
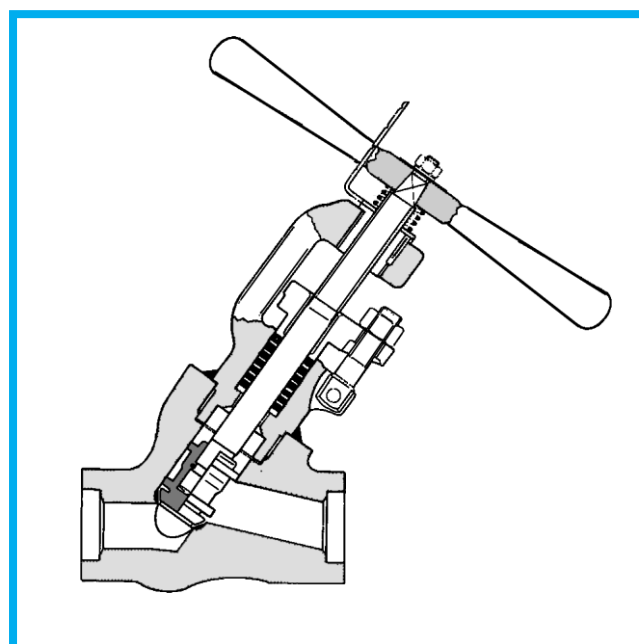
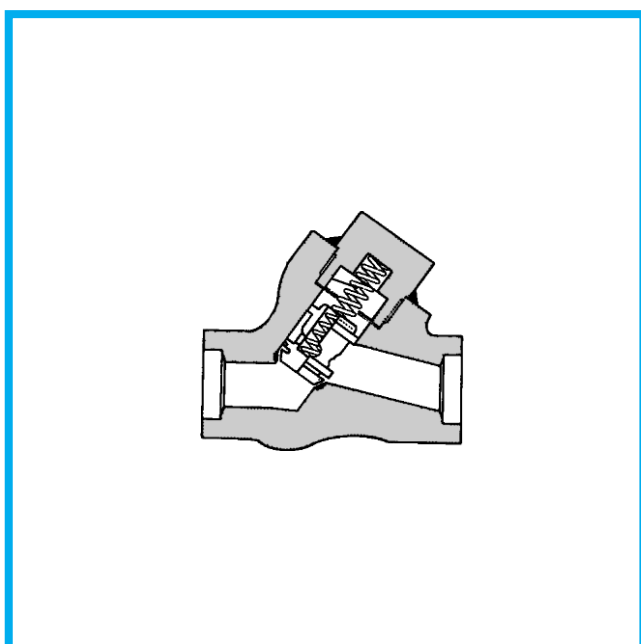

## INDEX

	Page		Page
<b>Material Schedules Table</b>	2	<b>ASME Class 2700 Valves</b>	9
<b>General Information</b>	3	Stop Valves	
<b>Construction details</b>	4-5	Piston Check Valves	
<b>ASME Class 600 Valves</b>	6	Manual Flow Control Valves	
Stop Valves		Stop-check Valves	
Piston Check Valves		<b>ASME Class 4500 Valves</b>	10
Manual Flow Control Valves		Stop Valves	
Stop-Check Valves		Piston Check Valves	
<b>ASME Class 900 Valves</b>	7	Manual Flow Control Valves	
Stop Valves		Stop-check Valves	
Piston Check Valves		<b>Connections</b>	11
Manual Flow Control Valves		<b>Materials</b>	12
Stop-Check Valves		<b>Rating</b>	13
<b>ASME Class 1700 Valves</b>	8	<b>PED Certification</b>	14
Stop Valves		<b>ISO 9001 Certification</b>	15
Piston Check Valves			
Manual Flow Control Valves			
Stop-Check Valves			

## FIGURE NUMBER INDEX

Fig.	Page	Fig.	Page	Fig.	Page	Fig.	Page	Fig.	Page	Fig.	Page	Fig.	Page
6001	4	6011	6	6031	8	6041	9	6051	10	6061	7	6101	11
6002	5	6012	6	6032	8	6042	9	6052	10	6062	7	6102	11
6003	5	6013	6	6033	8	6043	9	6053	10	6063	7	6102A	11
6004	5	6014	6	6034	8	6044	9	6054	10	6064	7	6103	11
6005	5												

## MATERIAL SCHEDULES

Item	Part	71	11	22	31	91
1	Body	ASTM A105 + Stellite Gr. 6	ASTM A182 F11 + Stellite Gr. 6	ASTM A182 F22 + Stellite Gr. 6	ASTM A182 F316 + Stellite Gr. 6	ASTM A182 F91 + Stellite Gr. 6
2	Bonnet					
2.2	Bonnet	ASTM A 105	ASTM A182 F11	ASTM A 182 F22	ASTM A182 F316	ASTM A182 F91
3	Disk					
3.2	Disk	Stellite Gr. 6 or ASTM A182 F6 + Stellite Gr. 6 (see Fig. 6005)	Stellite Gr. 6 or ASTM A182 F6 + Stellite Gr. 6 (see Fig. 6005)	Stellite Gr. 6 or ASTM A182 F6 + Stellite Gr. 6 (see Fig. 6005)	Stellite Gr. 6 or ASTM A479 T316 + Stellite Gr. 6 (see Fig. 6005)	Stellite Gr. 6 or ASTM A479 T316 + Stellite Gr. 6 (see Fig. 6005)
3.3	Disk					
3.4	Disk					
4	Stem					
4.4	Stem	ASTM A479 T.410 Cond. 3	ASTM A479 T.410 Cond. 3	ASTM A 479 T.410 Cond. 3	ASTM A564 T.630	ASTM A453 Gr. 660
5	Bottom Ring	Fe ARMCO	Fe ARMCO	Fe ARMCO	ASTM A479 T316	Fe ARMCO
6	Packing	Graphite	Graphite	Graphite	Graphite	Graphite
8	Swing Bolt	ASTM A193 B7	ASTM A193 B7	ASTM A193 B7	ASTM A193 B7	ASTM A193 B8
9	Pin	Alloy Steel	Alloy Steel	Alloy Steel	Alloy Steel	35NC6
10	Gland Flange	ASTM A105	ASTM A105	ASTM A105	ASTM A182 F316	ASTM A182 F316
11	Yoke Bushing	ASTM B150 C62300	ASTM B150 C62300	ASTM B150 C62300	ASTM B150 C62300	ASTM B150 C62300
12	Handle	ASTM A105	ASTM A105	ASTM A105	ASTM A105	ASTM A105
14	Disk Pad	ASTM A182 F6	ASTM A182 F6	ASTM A182 F6	ASTM A182 F6	AISI 420
15	Handle Nut	Carbon Steel	Carbon Steel	Carbon Steel	Carbon Steel	Carbon Steel
15A	Bolt Nut	ASTM A194 2H	ASTM A194 2H	ASTM A194 2H	ASTM A194 2H	ASTM A194 Gr 8
17	Washer	Carbon Steel	Carbon Steel	Carbon Steel	Carbon Steel	Carbon Steel
18	Disk Cap	ASTM A182 F6	ASTM A182 F6	ASTM A182 F6	ASTM A479 T316	ASTM A479 T316 + Stellite Gr 6
20	Name Plate	Stainless Steel	Stainless Steel	Stainless Steel	Stainless Steel	Stainless Steel
21	Spring	Inconel 600	Inconel 600	Inconel 600	Inconel 600	Inconel 600
23	Indicator	Carbon Steel	Carbon Steel	Carbon Steel	Carbon Steel	Carbon Steel
24	Spring	Alloy Steel	Alloy Steel	Alloy Steel	Alloy Steel	Alloy Steel
35	Grooved Rivet	Carbon Steel	Carbon Steel	Carbon Steel	Carbon Steel	Carbon Steel
70	Connecting Ring	Stellite	Stellite	Stellite	Stellite	Stellite

# BONT® Valves type WBY

## FOREWORD

Unlike many other manufacturers, we design, experiment, manufacture and test the most important BONT® Valve parts under one roof in our own facilities. Various sets of rigorous testing are done in order to ensure not only the complete satisfaction of the customers, but also to make sure our products are within the strict compliance guidelines of the most widely used international Standards.

## APPLICATION RANGE

The BONT® valves type WBY are designed to meet the requirements of most customers under the most severe applications, such as superheated steam at very high temperature and pressure, feed water at high pressure, vent and drain at the typical conditions of supercritical cycles as well as applications in chemical plants under higher pressure, e.g. NH<sub>3</sub> synthesis and also for petrochemical installations.

## DESIGN

WBY valves are "full-bore" valves. They are also "streamlined", i.e. their body is "Y pattern" with inclined stem. This design allows less fluid turbulence and higher flow coefficient values when compared to "T pattern" valves.

Body/bonnet welding provides perfect sealing of the body to bonnet screwed connection.

WBY valves disk is a "loose" disk, so that both in the closing operation as during opening and in back seating the disk moves axially, and does not rotate when it comes in contact with sealing surfaces. WBY valves can be easily maintained "on site", by removing the body/bonnet seal welding without dismantling valve from the piping. After inspection and/or maintenance, seal welding can be easily restored.

## OPERATION

WBY valves include the following designs: Stop, Piston-Check, Manual Flow Control and Stop-Check.

All designs, Piston-Check excepted, can be power actuated and can be furnished with a locking device in any position, including a padlock with key.

## RATINGS & STANDARDS (see Page 13)

WBY valves designs are in accordance to Class 600 - 900 - 1700 - 2700 - 4500 of the ASME B16.34 standard and also according to other internationally recognized standards, namely:

ASME B16.11 - ASME B16.25 - ASME B16.34 - ASTM Standards - MSS SP-25 - DIN 3239 - ASME Boiler and Pressure Vessel Code Sect. III.

Generally, WBY valves are oversized versus such Standards (see pag. 12, note 7)

In addition, valves for special operating conditions can be supplied on request.

## MATERIAL SCHEDULES

WBY valves are manufactured in different material selections or "schedules". By "schedule" we refer to the material composition of each valve component.

Below we list the main characteristic elements of the different material schedules:

Material Schedule	Body & Bonnet Material	Disc & Seat
71	ASTM A 105	
11	ASTM A 182 F11	
22	ASTM A 182 F22	Stellite Gr. 6
31	ASTM A 182 F316	
91	ASTM A 182 F91	

The seating surfaces of all BONT® WBY valves are hardened with Stellite Gr. 6, deposited into the body under highly specialized and automated procedure which guarantees the achievement of stated constant characteristics and dimensional uniformity. In some applications the disk could be supplied in precision cast Stellite Gr. 6.

## SIZES

WBY valves are manufactured in the following standard sizes and pressure classes, up to and including ASME Class 4500: 1/2" up to 4".

Valves sized 1/4" and 3/8" can be supplied on request.

## CONNECTIONS (see Page 11)

WBY valves are supplied with the following pipe connections:

- standard Socket Weld ASME B16.11
- on request Butt Weld ASME B16.25 or DIN 3239 or Threaded NPT ASME B1.20.1 or Flanged to ASME or DIN.

Valves over 2" cannot be supplied with socket weld ends

## FLOW COEFFICIENT

The flow coefficient values indicated for each valve in the following pages were measured experimentally in our plant, in accordance with ISA-S75.02.

Values are given in metric units (Kv) and in English units (Cv).

By definition, Kv is the number of m<sup>3</sup>/h of water that will flow through a fully opened valve with a pressure drop of 1 kg/cm<sup>2</sup>.

By definition, Cv is the volume of water at 60 °F in American gallons per minute which flow through a valve, in the fully opened position, under 1 psi differential pressure.

## CODE No.

The Code No. is composed as follows:

	Example
- Type of Valve: <b>WBY</b>	<b>WBY</b>
- Size: <b>005</b> = 1/2" <b>007</b> = 3/4"	
<b>010</b> = 1" <b>015</b> = 1.1/2"	<b>020</b>
<b>020</b> = 2" <b>025</b> = 2.1/2"	
<b>030</b> = 3" <b>040</b> = 4"	
- Operation: <b>IT</b> = Stop <b>RT</b> = Piston Check	<b>IT</b>
<b>RE</b> = Manual Flow Control	
<b>RI</b> = Stop-Check	
- Rating: <b>06</b> =600 - <b>09</b> =900 - <b>15</b> =1700;	<b>25</b>
<b>25</b> =2700; <b>45</b> =4500	
Material Schedule: <b>71</b> or <b>11</b> or <b>22</b> or <b>31</b> or <b>91</b>	<b>22</b>
- Connections: <b>OSW</b> = Socket Weld ASME	<b>OSW</b>
<b>BWA</b> = Butt Weld ASME	
<b>BWD</b> = Butt Weld DIN	
- Packing: <b>GR</b> =Graphite - <b>SP</b> =Special - <b>00</b> =Not used <b>GR</b>	<b>GR</b>
Resulting Code No. (as in example): <b>WBY020IT25220SWGR</b>	

## INSTALLATION

Welding procedures issued by an engineering company or final owner should be followed. However, it should be kept in mind that:

- Valve should be partially open during welding,
- If the valve will be normally closed, piping should be flushed, then the valve should open and close 2-3 times before finally seating, to prevent solid particles from remaining between seat and disk,
- WBY valves are fully suitable for acid washing,
- Check packing tightness during initial operation and eliminate any leakage by retorquing the swing bolt nuts.

## MAINTENANCE

Maintenance procedures and service bulletins are available on request. These include recommended tools and kits.

## SHIPPING PREPARATION

WBY valves must undergo complete dimensional and operational tests prior to shipment.

For storage and shipping protection, valves are coated with corrosion inhibitor oil on the internal areas, polyethylene caps on end connections, as well as stem thread protection. On request valves can be supplied with external painting or sealed in polyethylene bag for dry shipment and storage. Packing in suitably treated wooden cases is used where specified, required or recommended.

In order to continue our on-going research and development and the resulting improvement of our product, we reserve the right to make any changes or alterations to our product range, without prior notice.

**BONT® Valves type WBV**  
**ASME Class 600 - 900 - 1700 - 2700 - 4500**  
**Forged steel**  
**Screwed and welded body/bonnet connection**

ASME Class	Standard Material Schedule
600	71 - 11 - 22 - 31
900	71 - 11 - 22 - 31
1700	71 - 11 - 22 - 31 - 91
2700	71 - 22 - 31 - 91
4500	71 - 22 - 31 - 91

**Items**

Item	Part
1	Body
2	Bonnet
2.2	Bonnet
3	Disk
3.2	Disk
3.3	Disk
3.4	Disk
4	Stem
4.4	Stem
5	Bottom Ring
6	Packing
8	Swing Bolt
9	Pin
10	Gland Flange
11	Yoke Bushing
12	Handle
14	Disk Pad
15	Handle Nut
15A	Bolt Nut
17	Washer
18	Disk Cap
20	Name Plate
21	Spring
23	Indicator
24	Spring
35	Grooved Rivet
70	Connecting Ring

**MATERIAL SCHEDULES**

Here below we list the main characteristic elements of the different Material Schedules (See pag. 2 for complete Material Table):

Material Schedule	Body & Bonnet Material	Disc & Seat
71	ASTM A 105	Stellite Gr. 6
11	ASTM A 182 F11	
22	ASTM A 182 F22	
31	ASTM A 182 F316	
91	ASTM A 182 F91	

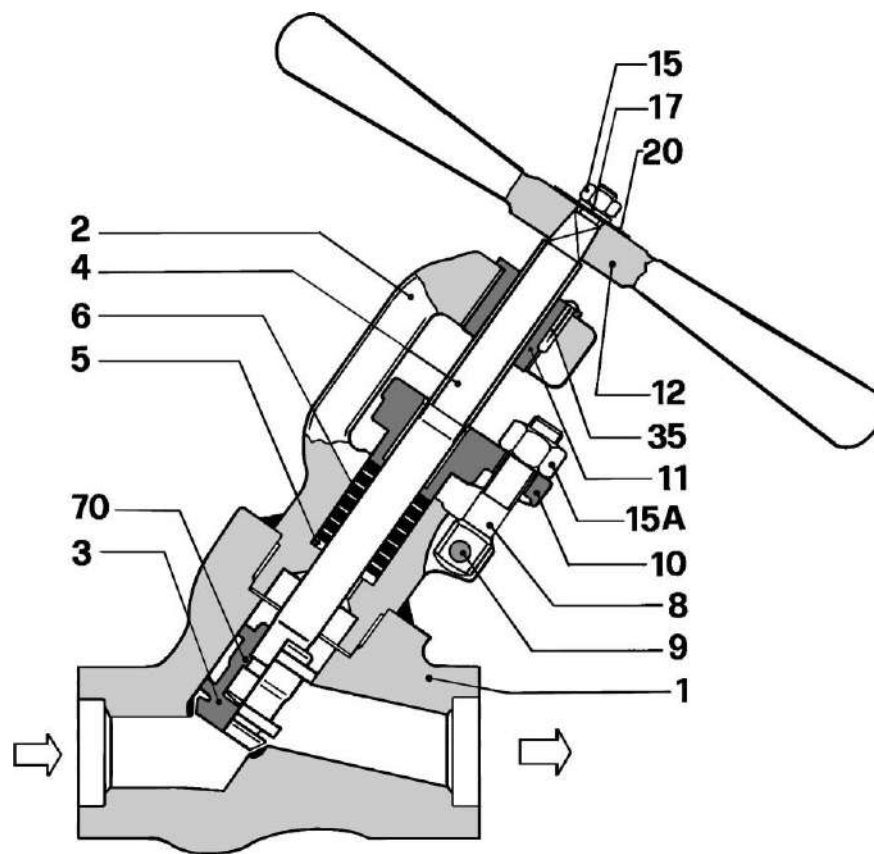

**1 BODY**

Always forged. Available in Carbon Steel, Cr Mo Low Alloy Steel or Stainless Steel. Streamlined internal contours and inclined stem permit "soft" flow and reduce losses of pressure. Passage contours minimize turbulence, vibration, erosion and are self-draining.

Integral seat is hard surfaced with Stellite Gr. 6, deposited with highly specialized automated procedure, which guarantees constant uniform characteristics for positive shut off and long life. The extra thickness of the deposited Stellite allows several subsequent renewal operations of the seating surface to insure continued positive shut off. Final machining of the seat surface and other surfaces in a single operation insures perfect alignment of all components.

**2 BONNET**

Always forged and of same material as the body. Screwed to body and seal welded to avoid any leakage. Welding lip contour can be easily removed allowing valve dismantling for

inspection or maintenance. Backseat is integrally machined and positively isolates the packing chamber from line pressure. On request backseat can be supplied with stellite hard face. Yoke design permits easy installation and removal of packing.

**3 DISK**

Seating surface is always Stellite Gr. 6. It is axially connected with the stem, but does not rotate with it. The disk is pushed against the seat or pulled against the backseat with axial non-rotating movement. Fully guided (bottom and top) in the body to prevent vibration in any position and also avoid side thrust against the stem. The design allows several surface renewal operations of the seating surface.

According to Class, Size and Operation of the valve, at our option, the disk is made in compliance with one of the following models (Fig. 6005):

- A - made of 13% Cr alloy steel or stainless steel, with seating surface and bottom-guide Stellite hardfaced. Consists of two precision welded parts (3 and 18) holding the Disk Pad (14) and the stem head in perfect alignment, lubricated for life,
- B - made same as in A, but with the addition of a second top-guide of Stellite Gr. 6,
- C - made of precision cast Stellite Gr. 6, with connection to the stem by the Connecting Ring (70), also made of Stellite.

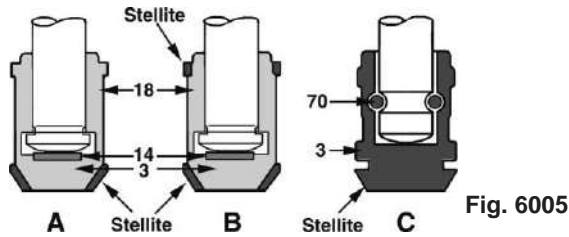

**4 STEM**

Composed of 13% Cr stainless steel, heat treated against corrosion and for the best mechanical characteristics. For Material Schedule 31 stem is made of special stainless steel ASTM A564 T.630 (17-4 PH).

Threads are ACME type. Surfaces are carefully machined for a longer life of the packing and yoke bushing threads.

**6 PACKING**

Standard packing chamber roughness is max. 32 microinches. Packing (6) is made of an adequate number of preformed Rings. Graphite is standard. Special materials available upon request.

**8 SWING BOLTS**

Made of heat treated alloy steel. Pins (9) are of the same material, permitting outside turning of the swing bolts for easier repacking.

**10 GLAND FLANGE**

Made of one piece of forged steel. Its design permits easy removal and allows ample space for repacking.

**11 YOKE BUSHING**

Usually made of special aluminum bronze. Accurate machining guarantees perfect alignment and lowest coefficient of friction with the stem and eliminates seizure possibility. It is screwed into the bonnet and fixed by one Grooved Rivet (35). Also available in NI-Resist to meet NACE Standards.

**12 HANDLE**

Made of forged steel. Its contour permits sure grip. A pyramid shaped square connection provides a perfect fit on the stem. Fixed on stem by hexagon Nut (15) and locking Washer (17). Handwheel is available on request instead of handle. Impactor handle is supplied on larger size and higher rating valves.

**20 NAME PLATE**

The Name Plate is fixed on each valve and bears all required indications or recommended information.

**ACTUATED VALVES**

Every WBY BONT® valve of any size, class and material schedule, Check Valves excepted, can be Power Actuated, with either electrical, hydraulic or pneumatic actuators.

Actuators are available with:

- torque limit switches, adjustable both at the time of delivery and on the plant during the operation,
- travel limit switches,
- local dial position indicators,
- "OPEN-CLOSED" indicating lights,
- auxiliary switches for various signals or operations,
- inductive or resistive position transmitter.

The BONT® Valves type WBY are also manufactured in these models:

**Piston Check Valve** (Fig. 6002), where the Disk (3.2) is free in the Body, but loaded against the seat by the helical Spring (21). The Bonnet (2.2) is blind and is screwed and seal welded to the body. Thanks to the body Y pattern and the helical spring, piston check valve operates perfectly on both horizontal and vertical pipes.

**Manual Flow Control Valve** (Fig. 6003), where the Disk (3.3) is contoured for flow regulation and fine control. Seating and regulating surface of disk can be Stellite Gr. 6 faced on request. The position of the valve is shown by the travel Indicator (23) kept in place by the Spring (24). Flow outlet characteristics are typically linear.

**Stop-Check Valve** (Fig. 6004), where the Disk (3.4) is allowed to slide on the Stem (4.4) while remaining connected. This allows valve, to act as a Piston Check valve when the stem is in the fully open position. With the stem screwed into the valve, flow is shut off in both directions. Since this valve does not have a spring, it must be installed in a position such that it allows the disk to close by gravity.

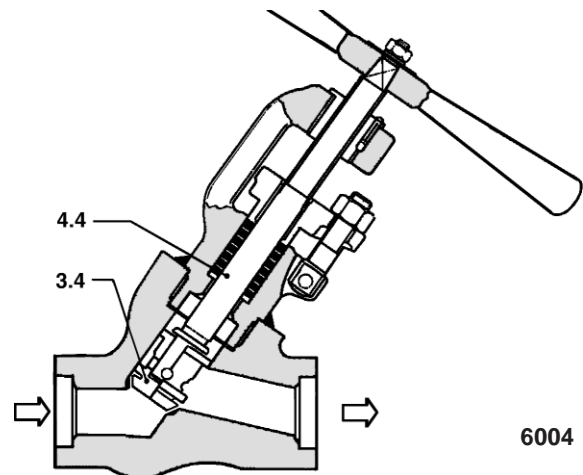
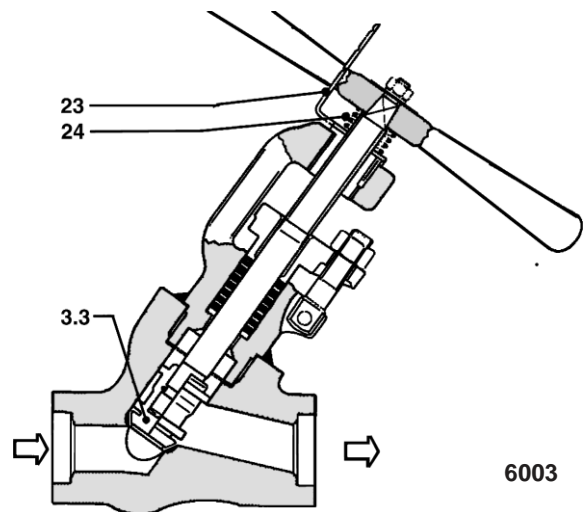
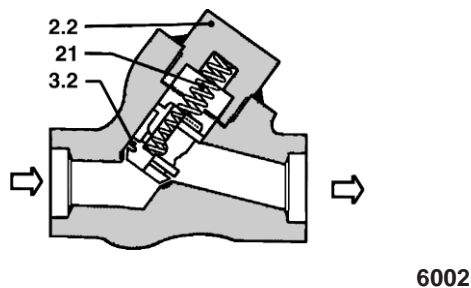

# BONT® Valves type WBV ASME Class 600

## Forged steel - Standard Material Schedule: 71 - 11 - 22 - 31

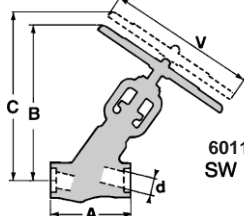
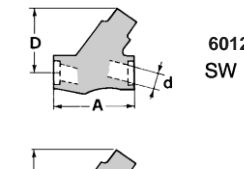
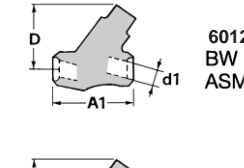
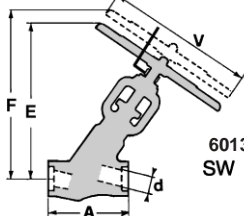
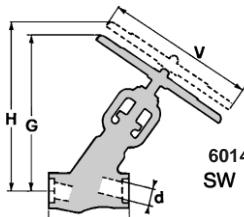
 <b>Stop Valves</b>	SIZE	A	A1	A2	B	C	V	d	Kv	Cv	Weight	Code Number							
	inches	mm	mm	mm	mm	mm	mm	mm			kg								
 <b>Piston Check Valves</b>	6011 SW	1/2"	105	105	105	185	200	160	12	4	5	2.5	WBV 005 IT 06	71 or 11 or 22 or 31	0SW or BWA or BWD	GR			
		3/4"	105	105	105	185	200	160	17.5	10	12	2.5	WBV 007 IT 06						
		1"	110	110	110	240	260	225	22.5	16	19	3.5	WBV 010 IT 06						
		1.1/2"	160	160	160	305	335	300	34	34	40	8.5	WBV 015 IT 06						
		2"	188	188	188	315	360	400	44	53	62	12	WBV 020 IT 06						
		2.1/2"		305	305	510	550	400	56	81	95	47	WBV 025 IT 06						
		3"		305	305	510	550	400	68	103	120	45	WBV 030 IT 06						
		4"		305	305	510	550	400	68	103	120	45	WBV 040 IT 06						
		6011.1 BW ASME																	
		6011.2 BW DIN																	
 <b>Piston Check Valves</b>	6012 SW	1/2"	105	105	105	75	12	4	5	1.8	WBV 005 RT 06	71 or 11 or 22 or 31	0SW or BWA or BWD	00					
		3/4"	105	105	105	75	17.5	10	12	1.8	WBV 007 RT 06								
		1"	110	110	110	80	22.5	16	19	2.5	WBV 010 RT 06								
		1.1/2"	160	160	160	110	34	34	40	5.5	WBV 015 RT 06								
		2"	188	188	188	150	44	53	62	9.5	WBV 020 RT 06								
		2.1/2"		305	305	235	56	81	95	32	WBV 025 RT 06								
		3"		305	305	235	68	103	120	30	WBV 030 RT 06								
		4"		305	305	235	68	103	120	30	WBV 040 RT 06								
		6012.1 BW ASME																	
		6012.2 BW DIN																	
 <b>Manual Flow Control Valves</b>	6013 SW	1/2"	105	105	105	185	200	160	12	4	5	2.5	WBV 005 RE 06	71 or 11 or 22 or 31	0SW or BWA or BWD	GR			
		3/4"	105	105	105	185	200	160	17.5	10	12	2.5	WBV 007 RE 06						
		1"	110	110	110	240	260	225	22.5	16	19	3.5	WBV 010 RE 06						
		1.1/2"	160	160	160	305	335	300	34	34	40	8.5	WBV 015 RE 06						
		2"	188	188	188	315	360	400	44	53	62	12	WBV 020 RE 06						
		2.1/2"		305	305	510	550	400	56	81	95	47	WBV 025 RE 06						
		3"		305	305	510	550	400	68	103	120	45	WBV 030 RE 06						
		4"		305	305	510	550	400	68	103	120	45	WBV 040 RE 06						
		6013.1 BW ASME																	
		6013.2 BW DIN																	
 <b>Stop - Check Valves</b>	6014 SW	1/2"	105	105	105	185	200	160	12	4	5	2.5	WBV 005 RI 06	71 or 11 or 22 or 31	0SW or BWA or BWD	GR			
		3/4"	105	105	105	185	200	160	17.5	10	12	2.5	WBV 007 RI 06						
		1"	110	110	110	240	260	225	22.5	16	19	3.5	WBV 010 RI 06						
		1.1/2"	160	160	160	305	335	300	34	34	40	8.5	WBV 015 RI 06						
		2"	188	188	188	315	360	400	44	53	62	12	WBV 020 RI 06						
		2.1/2"		305	305	510	550	400	56	81	95	47	WBV 025 RI 06						
		3"		305	305	510	550	400	68	103	120	45	WBV 030 RI 06						
		4"		305	305	510	550	400	68	103	120	45	WBV 040 RI 06						
		6014.1 BW ASME																	
		6014.2 BW DIN																	

Dimensions d1 and d2 depend on requested BW connections - (see pag. 11)

## BONT® Valves type WBY - ASME Class 900

### Forged steel - Standard Material Schedule: 71 - 11 - 22 - 31

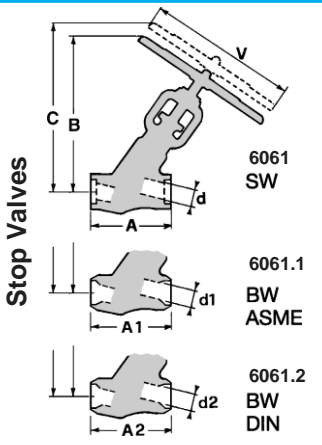
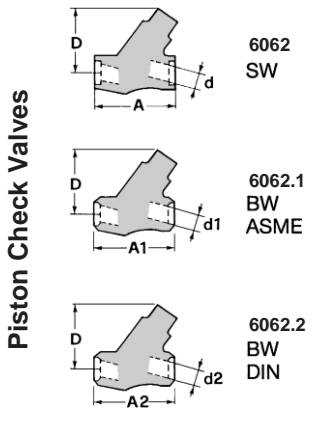
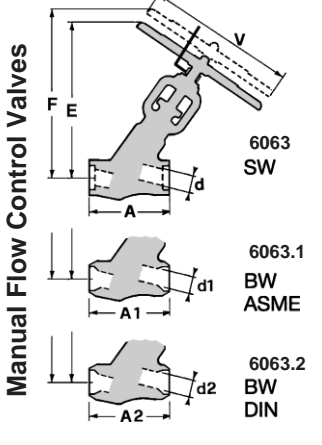
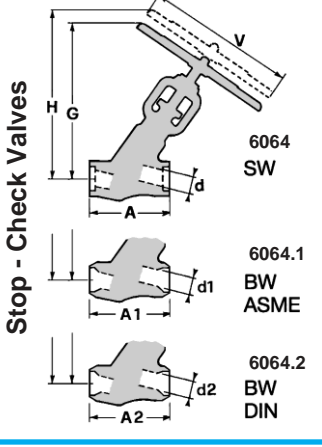
		SIZE									Weight	Code Number							
			A	A1	A2	B	C	V	d	Kv		Cv	inches	mm	mm	mm	mm	mm	mm
	<b>6061 SW</b>  <b>6061.1 BW ASME</b>  <b>6061.2 BW DIN</b>	1/2"	105	105	105	185	200	160	12	4	5	2.5	WBY 005 IT 09	71 or 11 or 22 cr 31	(SW or BWA or BWD	GR			
		3/4"	105	105	105	185	200	160	17.5	10	12	2.5	WBY 007 IT 09			GR			
		1"	110	110	110	240	260	225	22.5	16	19	3.5	WBY 010 IT 09			GR			
		1.1/2"	160	160	160	305	335	300	34	34	40	8.5	WBY 015 IT 09			GR			
		2"	188	188	188	315	360	400	44	53	62	12	WBY 020 IT 09			GR			
		2.1/2"	305	305	305	510	550	400	56	81	95	47	WBY 025 IT 09			GR			
		4"	305	305	305	510	550	400	68	103	120	45	WBY 040 IT 09			GR			
	<b>6062 SW</b>  <b>6062.1 BW ASME</b>  <b>6062.2 BW DIN</b>	1/2"	105	105	105	75	12	4	5	1.8	WBY 005 RT 09	71 or 11 or 22 r 31	)SW or B A or BWD	00					
		3/4"	105	105	105	75	17.5	10	12	1.8	WBY 007 RT 09			00					
		1"	110	110	110	80	22.5	16	19	2.5	WBY 010 RT 09			00					
		1.1/2"	160	160	160	110	34	34	40	5.5	WBY 015 RT 09			00					
		2"	188	188	188	150	44	53	62	9.5	WBY 020 RT 09			00					
		2.1/2"	305	305	305	235	56	81	95	32	WBY 025 RT 09			00					
		4"	305	305	305	235	68	103	120	30	WBY 040 RT 09			00					
	<b>6063 SW</b>  <b>6063.1 BW ASME</b>  <b>6063.2 BW DIN</b>	1/2"	105	105	105	185	200	160	12	4	5	2.5	WBY 005 RE 09	71 or 11 or 22 or 31	)SW or B A or BWD	GR			
		3/4"	105	105	105	185	200	160	17.5	10	12	2.5	WBY 007 RE 09			GR			
		1"	110	110	110	240	260	225	22.5	16	19	3.5	WBY 010 RE 09			GR			
		1.1/2"	160	160	160	305	335	300	34	34	40	8.5	WBY 015 RE 09			GR			
		2"	188	188	188	315	360	400	44	53	62	12	WBY 020 RE 09			GR			
		2.1/2"	305	305	305	510	550	400	56	81	95	47	WBY 025 RE 09			GR			
		4"	305	305	305	510	550	400	68	103	120	45	WBY 040 RE 09			GR			
	<b>6064 SW</b>  <b>6064.1 BW ASME</b>  <b>6064.2 BW DIN</b>	1/2"	105	105	105	185	200	160	12	4	5	2.5	WBY 005 RI 09	71 or 11 or 22 or 31	)SW or BWA or BWD	GR			
		3/4"	105	105	105	185	200	160	17.5	10	12	2.5	WBY 007 RI 09			GR			
		1"	110	110	110	240	260	225	22.5	16	19	3.5	WBY 010 RI 09			GR			
		1.1/2"	160	160	160	305	335	300	34	34	40	8.5	WBY 015 RI 09			GR			
		2"	188	188	188	315	360	400	44	53	62	12	WBY 020 RI 09			GR			
		2.1/2"	305	305	305	510	550	400	56	81	95	47	WBY 025 RI 09			GR			
		4"	305	305	305	510	550	400	68	103	120	45	WBY 040 RI 09			GR			

Dimensions d1 and d2 depend on requested BW connections - (see pag. 11)

## BONT® Valves type WBV - ASME Class 1700

Forged steel - Standard Material Schedule: 71 - 11 - 22 - 31 - 91

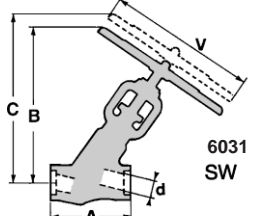
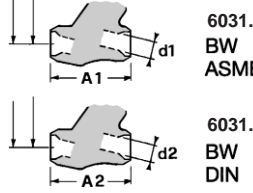
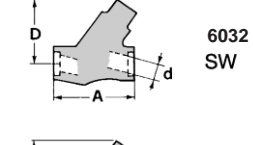
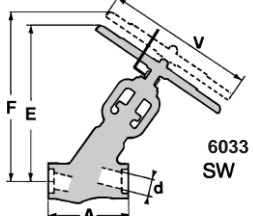
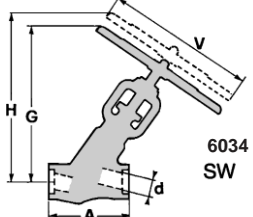
 Stop Valves	SIZE	A	A1	A2	B	C	V	d	Kv	Cv	Weight	Code Number					
	inches	mm	mm	mm	mm	mm	mm	mm			kg						
 6031 SW 6031.1 BW ASME 6031.2 BW DIN	1/2"	105	105	105	185	200	160	12	4	5	2.5	WBV 005 IT 15	71 or 11 or 22 or 31 or 91	OSW or BWA or BWD	GR		
	3/4"	105	105	105	185	200	160	17.5	10	12	2.5	WBV 007 IT 15					
	1"	110	110	110	240	260	225	22.5	16	19	3.5	WBV 010 IT 15					
	1.1/2"	160	160	160	305	335	300	34	34	40	8.5	WBV 015 IT 15					
	2"	188	188	188	315	360	400	44	53	62	12	WBV 020 IT 15					
	2.1/2"		305	305	510	550	400	50	73	85	48	WBV 025 IT 15					
	3"		305	305	510	550	400	60	86	100	46	WBV 030 IT 15					
	4"		305	305	510	550	400	60	86	100	46	WBV 040 IT 15					
	 6032 SW 6032.1 BW ASME 6032.2 BW DIN	SIZE	A	A1	A2	D	d	Kv	Cv	Weight	Code Number						
		inches	mm	mm	mm	mm	mm			kg							
1/2"		105	105	105	75	12	4	5	1.8	WBV 005 RT 15	71 or 11 or 22 or 31 or 91	OSW or BWA or BWD	00				
3/4"		105	105	105	75	17.5	10	12	1.8	WBV 007 RT 15							
1"		110	110	110	80	22.5	16	19	2.5	WBV 010 RT 15							
1.1/2"		160	160	160	110	34	34	40	5.5	WBV 015 RT 15							
2"		188	188	188	150	44	53	62	9.5	WBV 020 RT 15							
2.1/2"			305	305	235	50	73	85	32	WBV 025 RT 15							
3"			305	305	235	60	86	100	31	WBV 030 RT 15							
4"			305	305	235	60	86	100	31	WBV 040 RT 15							
 6033 SW 6033.1 BW ASME 6033.2 BW DIN	SIZE	A	A1	A2	E	F	V	d	Kv	Cv				Weight	Code Number		
	inches	mm	mm	mm	mm	mm	mm	mm						kg			
	1/2"	105	105	105	195	210	160	12	4	5	2.8	WBV 005 RE 15	71 or 11 or 22 or 31 or 91	OSW or BWA or BWD	GR		
	3/4"	105	105	105	195	210	160	17.5	10	12	2.8	WBV 007 RE 15					
	1"	110	110	110	250	270	225	22.5	16	19	3.8	WBV 010 RE 15					
	1.1/2"	160	160	160	315	345	300	34	34	40	9.0	WBV 015 RE 15					
	2"	188	188	188	430	465	400	44	53	62	12.5	WBV 020 RE 15					
	2.1/2"		305	305	520	560	400	50	73	85	49	WBV 025 RE 15					
	3"		305	305	520	560	400	60	86	100	47	WBV 030 RE 15					
	4"		305	305	520	560	400	60	86	100	47	WBV 040 RE 15					
 6034 SW 6034.1 BW ASME 6034.2 BW DIN	SIZE	A	A1	A2	G	H	V	d	Kv	Cv	Weight	Code Number					
	inches	mm	mm	mm	mm	mm	mm	mm			kg						
	1/2"	105	105	105	185	200	160	12	4	5	2.5	WBV 005 RI 15	71 or 11 or 22 or 31 or 91	OSW or BWA or BWD	GR		
	3/4"	105	105	105	185	200	160	17.5	10	12	2.5	WBV 007 RI 15					
	1"	110	110	110	240	260	225	22.5	16	19	3.5	WBV 010 RI 15					
	1.1/2"	160	160	160	305	335	300	34	34	40	8.5	WBV 015 RI 15					
	2"	188	188	188	315	360	400	44	53	62	12	WBV 020 RI 15					
	2.1/2"		305	305	510	550	400	50	73	85	48	WBV 025 RI 15					
	3"		305	305	510	550	400	60	86	100	46	WBV 030 RI 15					
	4"		305	305	510	550	400	60	86	100	46	WBV 040 RI 15					

Dimensions d1 and d2 depend on requested BW connections - (see pag. 11)

## BONT® Valves type WBY - ASME Class 2700

### Forged steel - Standard Material Schedule: 71 - 22 - 31 - 91

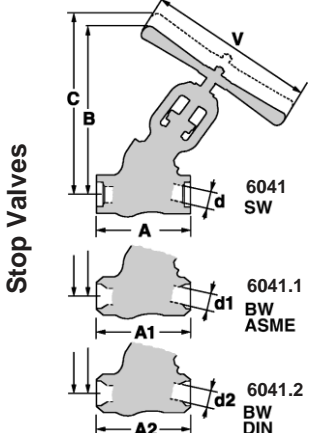
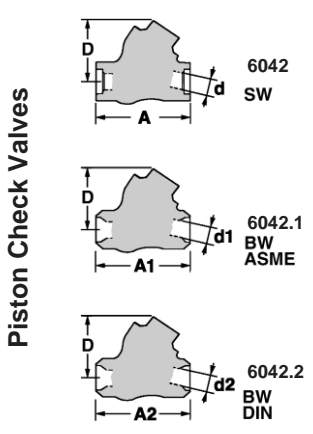
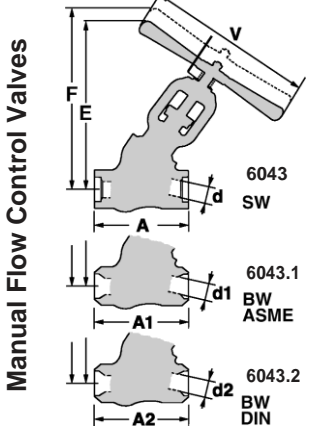
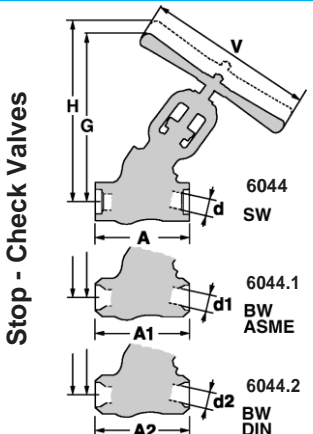
		SIZE									Weight	Code Number							
			A	A1	A2	B	C	V	d	Kv		Cv	inches	mm	mm	mm	mm	mm	mm
 <p style="text-align: center;"><b>Stop Valves</b></p>																			
	1/2"	110	110	110	240	260	225	14	4	5	4.0	WBY 005 IT 25	71 or 22 or 31 or 91	OSW or BWA or BWD	GR				
	3/4"	110	110	110	240	260	225	14	6	7.5	4.0	WBY 007 IT 25							
	1"	154	154	154	300	320	300	19.5	10	12	8.0	WBY 010 IT 25							
	1.1/2"	224	224	224	420	460	400	30	34	40	27	WBY 015 IT 25							
	2"	224	224	224	420	460	400	39.5	53	62	26	WBY 020 IT 25							
	2.1/2"		305	305	510	550	400	50	73	85	48	WBY 025 IT 25							
	3"		305	305	510	550	400	60	85	100	46	WBY 030 IT 25							
4"		305	305	510	550	400	60	85	100	46	WBY 040 IT 25								
 <p style="text-align: center;"><b>Piston Check Valves</b></p>																			
	1/2"	110	110	110	80	14	4	5	2.5	WBY 005 RT 25	71 or 22 or 31 or 91	OSW or B A or BWD	00						
	3/4"	110	110	110	80	14	6	7.5	2.5	WBY 007 RT 25									
	1"	154	154	154	105	22.5	10	12	5.0	WBY 010 RT 25									
	1.1/2"	224	224	224	160	19.5	34	40	15	WBY 015 RT 25									
	2"	224	224	224	160	39.5	53	62	14	WBY 020 RT 25									
	2.1/2"		305	305	235	50	73	85	32	WBY 025 RT 25									
	3"		305	305	235	60	85	100	31	WBY 030 RT 25									
4"		305	305	235	60	85	100	31	WBY 040 RT 25										
 <p style="text-align: center;"><b>Manual Flow Control Valves</b></p>																			
	1/2"	110	110	110	240	260	225	14	4	5	4.2	WBY 005 RE 25	71 or 22 or 31 r 91	OSW or B A or BWD	GR				
	3/4"	110	110	110	240	260	225	14	6	7.5	4.2	WBY 007 RE 25							
	1"	154	154	154	300	320	300	19.5	10	12	8.5	WBY 010 RE 25							
	1.1/2"	224	224	224	420	460	400	30	34	40	27	WBY 015 RE 25							
	2"	224	224	224	420	460	400	39.5	53	62	26.5	WBY 020 RE 25							
	2.1/2"		305	305	510	550	400	50	73	85	49	WBY 025 RE 25							
	3"		305	305	510	550	400	60	85	100	47	WBY 030 RE 25							
4"		305	305	510	550	400	60	85	100	47	WBY 040 RE 25								
 <p style="text-align: center;"><b>Stop - Check Valves</b></p>																			
	1/2"	110	110	110	240	260	225	14	4	5	4.0	WBY 005 RI 25	71 or 22 or 31 or 91	OSW or B A or BWD	GR				
	3/4"	110	110	110	240	260	225	14	6	7.5	4.0	WBY 007 RI 25							
	1"	154	154	154	300	320	300	19.5	10	12	8.0	WBY 010 RI 25							
	1.1/2"	224	224	224	420	460	400	30	34	40	27	WBY 015 RI 25							
	2"	224	224	224	420	460	400	39.5	53	62	26	WBY 020 RI 25							
	2.1/2"		305	305	510	550	400	50	73	85	48	WBY 025 RI 25							
	3"		305	305	510	550	400	60	85	100	46	WBY 030 RI 25							
4"		305	305	510	550	400	60	85	100	46	WBY 040 RI 25								

Dimensions d1 and d2 depend on requested BW connections - (see pag. 11)

## BONT® Valves type WBV - ASME Class 4500

Forged steel - Standard Material Schedule: 71 - 22 - 31 - 91

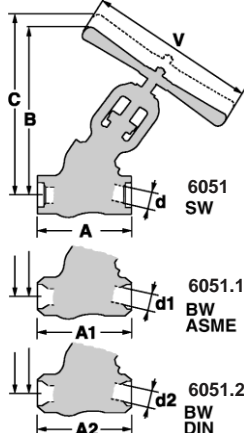
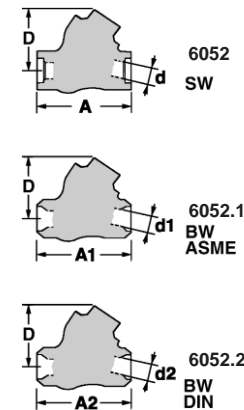
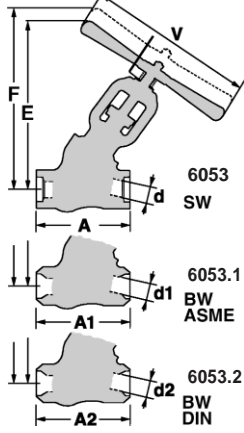
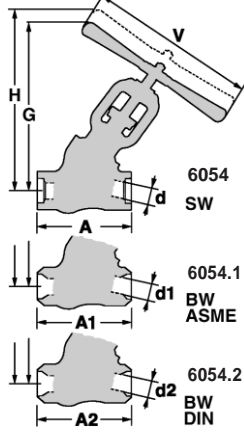
 Stop Valves	SIZE	A	A1	A2	B	C	V	d	Kv	Cv	Weight	Code Number						
	inches	mm	mm	mm	mm	mm	mm	mm			kg							
 Piston Check Valves	1/2"	154	154	154	300	320	300	12	2	2.5	9.0	WBV 005 IT 45	71 or 22 or 31 or 91	0SW or BWA or BWD	GR			
	3/4"	154	154	154	300	320	300	12	4	4.5	9.0	WBV 007 IT 45			GR			
	1"	154	154	154	300	320	300	14	6	7	8.5	WBV 010 IT 45			GR			
	1.1/2"	224	224	224	420	455	400	31	21	25	26.5	WBV 015 IT 45			GR			
	2"	224	224	224	420	455	400	31	24	28	26	WBV 020 IT 45			GR			
	2.1/2"	305	305	305	510	550	400	40	56	65	50	WBV 025 IT 45			GR			
	3"	305	305	305	510	550	400	40	56	65	50	WBV 030 IT 45			GR			
	4"	305	305	305	510	550	400	40	56	65	50	WBV 040 IT 45			GR			
	1/2"	110	110	110	80	80	14	4	5	2.5	WBV 005 RT 45	71 or 22 or 31 or 91			0SW or B or BWD	00		
	3/4"	110	110	110	80	80	14	6	7.5	2.5	WBV 007 RT 45					00		
1"	154	154	154	105	22.5	10	12	5.0	WBV 010 RT 45	00								
1.1/2"	224	224	224	160	19.5	34	40	15	WBV 015 RT 45	00								
2"	224	224	224	160	39.5	53	62	14	WBV 020 RT 45	00								
2.1/2"	305	305	305	235	50	73	85	32	WBV 025 RT 45	00								
3"	305	305	305	235	60	85	100	31	WBV 030 RT 45	00								
4"	305	305	305	235	60	85	100	31	WBV 040 RT 45	00								
 Manual Flow Control Valves	1/2"	154	154	154	310	330	300	12	2	2.5	9.5		WBV 005 RE 45	71 or 22 or 31 or 91		0SW or B or BWD	GR	
	3/4"	154	154	154	310	330	300	12	4	4.5	9.5		WBV 007 RE 45				GR	
	1"	154	154	154	310	330	300	14	6	7	9.0	WBV 010 RE 45	GR					
	1.1/2"	224	224	224	430	465	400	31	21	25	27	WBV 015 RE 45	GR					
	2"	224	224	224	430	465	400	31	24	28	26.5	WBV 020 RE 45	GR					
	2.1/2"	305	305	305	520	560	400	40	56	65	51	WBV 025 RE 45	GR					
	3"	305	305	305	520	560	400	40	56	65	51	WBV 030 RE 45	GR					
	4"	305	305	305	520	560	400	40	56	65	51	WBV 040 RE 45	GR					
	 Stop - Check Valves	1/2"	154	154	154	300	320	300	12	2	2.5	9.0	WBV 005 RI 45		71 or 22 or 31 or 91		0SW or B or BWD	GR
		3/4"	154	154	154	300	320	300	12	4	4.5	9.0	WBV 007 RI 45					GR
1"		154	154	154	300	320	300	14	6	7	8.5	WBV 010 RI 45	GR					
1.1/2"		224	224	224	420	455	400	31	21	25	26.5	WBV 015 RI 45	GR					
2"		224	224	224	420	455	400	31	24	28	26	WBV 020 RI 45	GR					
2.1/2"		305	305	305	510	550	400	40	56	65	50	WBV 025 RI 45	GR					
3"		305	305	305	510	550	400	40	56	65	50	WBV 030 RI 45	GR					
4"		305	305	305	510	550	400	40	56	65	50	WBV 040 RI 45	GR					

Dimensions d1 and d2 depend on requested BW connections - (see pag. 11)

## CONNECTIONS

### Socket Weld (S.W.) Connections ASME B 16.11

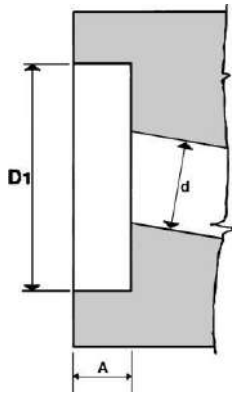

6101

Size	Inches		Millimeters	
	D1 minimum	A minimum	D1 minimum	A minimum
1/4"	.555	3/8	14,10	9,53
3/8"	.690	3/8	17,53	9,53
1/2"	.855	3/8	21,72	9,53
3/4"	1.065	1/2	27,06	12,70
1"	1.330	1/2	33,79	12,70
1.1/4"	1.675	1/2	42,55	12,70
1.1/2"	1.915	1/2	48,65	12,70
2"	2.406	5/8	61,12	15,88

- Above sizes expressed in inches are taken from ASME B16.11 (for details see above Standard).
- Sizes expressed in millimeters are converted from those in inches, they are not binding and are only as indication for user's convenience.
- Minimum wall thickness of socket welding is according to ASME B 1 6.34.

### Butt Weld (B.W.) Connections ASME B 16.25

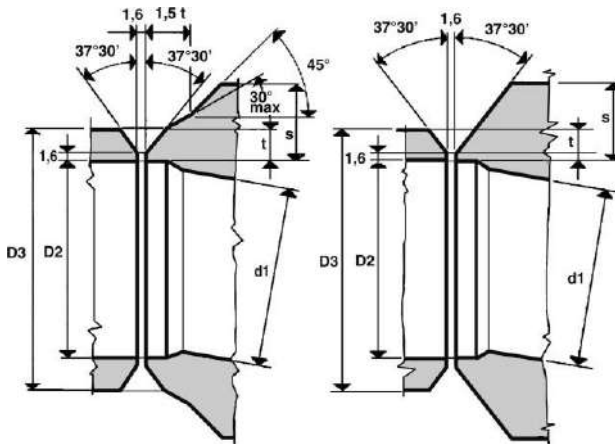

6102

6102A

Dimension of Pipes, according to ASME B 36.10						
SIZE	Schedule 80	Schedule 160	Schedule 03	XXS		
	D3 t	D3 t	D3 t	D3 t		
	mm (in)	mm (in)	mm (in)	mm (in)		
1/2"	21.3 (0.840) 3.73 (0.147)	21.3 (0.840) 4.78 (0.188)	21.3 (0.840) 7.47 (0.294)	21.3 (0.840) 7.82 (0.308)		
3/4"	26.7 (1.050) 3.91 (0.154)	26.7 (1.050) 5.56 (0.219)	26.7 (1.050) 9.09 (0.358)	26.7 (1.050) 9.09 (0.358)		
1"	33.4 (1.315) 4.55 (0.179)	33.4 (1.315) 6.35 (0.250)	33.4 (1.315) 10.15 (0.400)	33.4 (1.315) 10.15 (0.400)		
1.1/2"	48.3 (1.900) 5.08 (0.200)	48.3 (1.900) 7.14 (0.281)	48.3 (1.900) 11.07 (0.436)	48.3 (1.900) 11.07 (0.436)		
2"	60.3 (2.375) 5.54 (0.218)	60.3 (2.375) 8.74 (0.344)	60.3 (2.375) 14.02 (0.552)	60.3 (2.375) 14.02 (0.552)		
2.1/2"	73.0 (2.875) 7.01 (0.276)	73.0 (2.875) 9.53 (0.375)	73.0 (2.875) 15.24 (0.600)	73.0 (2.875) 15.24 (0.600)		
3"	88.9 (3.500) 7.62 (0.300)	88.9 (3.500) 11.13 (0.438)	88.9 (3.500) 17.12 (0.674)	88.9 (3.500) 17.12 (0.674)		
4"	114.3 (4.500) 8.56 (0.337)	114.3 (4.500) 13.49 (0.531)				

- Fig. 6102: Applicable for thickness of valve wall  $s > 22,2$  mm
- Fig. 6102A: Applicable for thickness of valve  $s = 22,2$  mm
- Dimension d1 depends on requested Schedule.

### Butt Weld (B.W.) Connections DIN 3239

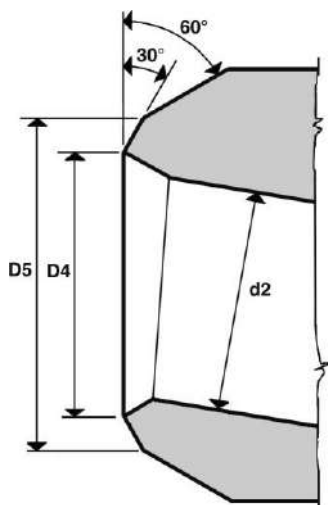

6103

Size	D4 D5	PN 100	PN 160	PN 250	PN 320	PN 400	PN 640
		D4 D5	D4 D5	D4 D5	D4 D5	D4 D5	D4 D5
10 3/8"	13 20	13 20	12 20	12 20	10 20	11 24	
15 1/2"	17 24	17 24	16 24	15 24	17 31	16 25	
25 1"	28 37	27 37	27 39	24 39	28 48	24 52	
40 1.1/2"	43 54	41 54	38 54	35 54	38 57	34 72	
50 2"	54 67	52 67	47 67	47 71	48 83	46 92	
65 2.1/2"	70 83	65 83	59 83	65 96	68 110	-- --	
80 3"	82 96	76 96	79 110	76 110	78 122	-- --	
100 4"	106 121	97 121	97 129	-- --	-- --	-- --	

- Above sizes - in millimeters - are taken from DIN 3239, Form D, Ausführung 2 (see above Standard for details).
- When ordering valves with butt weld connections, please indicate size of pipe to be welded to valve.
- Dimension d2 depends on requested PN.

# MATERIALS

Material	ASTM A105	ASTM A182F11	ASTM A182F22	ASTM A182F316	ASTM A182F91	Stellite Gr.6	ASTM A479 T.410C.3	ASTM A193 B7	ASTM A182 F XM 19	ASTM A194 2H	ASTM B150 C62300	ASTM B166 N06600	ASTM A182 F6	ASTM A564T.63 Cond.H107	ASTM A453 Gr. 660	
<b>Chemical Analysis</b>	(Note 1)															
Carbon	% 0.35 max	0.10-0.20	0.15 max	0.08 max	0.08-0.12	1	0.13 max	0.38-0.48	0.06 max	0.40 max		0.15 max	0.15 max	0,07	0.08 max	
Manganese	% 0.60-105	0.30-0.80	0.30-0.60	2.00 max	0.30-0.60		1.00 max	0.75-1.00	4.0-6.0		0.5 max	1.0 max	1.00 max	1.0 max	2.00 max	
Phosphorus	% 0.04 max	0.04 max	0.04 max	0.04 max	0.02 max		0.04 max	0.04 max	0.04 max	0.04 max			0.04 max	0.04 max	0.040 max	
Sulphur	% 0.05 max	0.04 max	0.04 max	0.03 max	0.01 max		0.03 max	0.04 max	0.03 max	0.05 max		0.015 max	0.30 max	0.03 max	0.030 max	
Silicon	% 0.35 max	0.5-1.0	0.5 max	1.00 max	0.20-0.50		1.00 max	0.20-0.35	1.00 max		0.25 max	0.5 max	1.00 max	1.0 max	1.00 max	
Chromium	%	1.0-1.5	2.0-2.5	16.00-18.00	8.00-9.50	28	11.5-13.5	0.80-1.10	20.5-23.5			14.0-17.0	11.5-13.5	15.0-17.5	13.5-16.0	
Nickel	%			10.00-14.00	0.40 max		0.50 max		11.5-13.5		1.0 max	72 min+C	0.50 max	3.0-5.0	24.0-27.0	
Molybdenum	%	0.44-0.65	0.87-1.13	2.00-3.00	0.85-1.05			0.15-0.25	1.5-3.0					1.2-2.0	1.0-1.5	
Copper	%										82.2 min	0.50 max		3.0-5.0		
Aluminium	%										8.5-10.0				0.35 max	
Iron	%										2.0-4.0	6.0-10.0				
Cobalt	%					66										
Tungsten	%					5										
Titanium	%														1.90-2.35	
Columbium	%								0.10-0.30							
<b>Mechanical features</b>							(Note 2)				(Note 2)	(Note 2)				
Tensile Strength	psi	70000	70000	75000	75000	85000		130000	125000	100000		78000	155000	110000	145000	130000
	MPa	485	485	515	515	585		900	860	690		542	1.069	760	1000	895
Yield Strength	psi	36000	40000	45000	30000	60000		100000	105000	55000		32000	90000	85000	125000	85000
	MPa	250	275	310	205	415		690	720	380		221	620	585	862	585
Elongation on 2" %min							12	16	35		15	10	15	13	15	

## Notes for Materials (Those Notes apply also to Rating Tables on page 13)

- 1 We utilize also steel with lower Carbon content ( $\leq 0,25\%$ ).
- 2 Mechanical features depend on heat treatment. Prescribed heat treatment permits us to obtain the most suitable physical and chemical characteristics.

## Notes for Rating (Those Notes apply also to Rating Tables on page 13)

- 3 Ratings of tables are those indicated by ASME B 16.34 for Classes 600 - 900 - 1500 - 2500 - 4500 and extrapolated for Classes 1700-2700
- 4 Due to a possible transformation of carbides into graphite, ASME B 16.34 does not recommend the use of Carbon steel valves (BONETTI Mat. Sch. 71) over 800°F (425°C) for extended periods.
- 5 For ASTM A182 F11 and for ASTM A182 F22 (BONETTI Mat. Sch. 11 and 22) ASME B 16.34 recommends: "Use normalized and tempered material only - Not to be used over 1100 °F (595 °C).
- 6 At temperature above 1000 °F (538 °C) material ASTM A182 F316 (BONETTI Mat. Sch. 31) must be used only when the Carbon content is 0.04% or higher.
- 7 As BONT valves are oversized versus International Standard prescription, including ASME B 16.34, effective maximum operating condition can be communicated on request.

# RATING

Operating temperature °F	Max operating pressure psi ASME Class 600				Max operating pressure psi ASME Class 900				Max operating pressure psi ASME Class 1700				Max operating pressure psi ASME Class 2700					Max operating pressure psi ASME Class 4500				
	Material Schedule				Material Schedule				Material Schedule				Material Schedule					Material Schedule				
	71	11	22	31	71	11	22	31	71	11	31	91	71	11	22	31	91	71	11	22	31	91
-20+100	1480	1500	1500	1440	2220	2250	2250	2160	4198	4250	4080	4250	6664	6750	6750	6480	6750	11110	11250	11250	10800	11250
200	1350	1500	1500	1240	2025	2250	2250	1860	3825	4250	3508	4250	6075	6750	6750	5573	6750	10120	11250	11250	9290	11250
300	1315	1445	1455	1120	1970	2165	2185	1680	3718	4091	3168	4126	5908	6497	6556	5033	6556	9845	10830	10925	8390	10925
400	1270	1385	1410	1025	1900	2080	2115	1540	3592	3927	2912	4000	5703	6238	6351	4623	6351	9505	10400	10585	7705	10585
500	1200	1330	1330	955	1795	1995	1995	1435	3394	3768	2708	3768	5389	5983	5983	4299	5983	8980	9965	9965	7165	9965
600	1095	1210	1210	900	1640	1815	1815	1355	3100	3428	2556	3428	4925	5443	5443	4061	5443	8210	9070	9070	6770	9070
650	1075	1175	1175	890	1610	1765	1765	1330	3043	3333	2516	3333	4833	5297	5297	3996	5297	8055	8825	8825	6660	8825
700	1065	1135	1135	870	1600	1705	1705	1305	3020	3218	2460	3218	4795	5109	5109	3910	5109	7990	8515	8515	6515	8515
750	1010	1065	1065	855	1510	1595	1595	1280	2856	3014	2420	3014	4536	4784	4784	3845	4784	7560	7970	7970	6410	7970
800	825	1015	1015	845	1235	1525	1525	1265	2334	2878	2392	2878	3704	4568	4568	3802	4568	6170	7610	7610	6335	7610
850	535	975	975	835	805	1460	1460	1255	1518	2760	2368	2760	2408	4385	4385	3759	4385	4010	7305	7305	6265	7305
900	345	900	900	830	515	1350	1350	1245	974	2545	2352	2545	1544	4045	4045	3737	4045	2570	6740	6740	6230	6740
950	205	640	755	775	310	955	1130	1160	584	1807	2188	2188	929	2868	3397	3478	3478	1545	4785	5665	5795	5795
1000	105	430	520	700	155	650	780	1050	294	1224	1983	2062	464	1944	2344	3148	3272	770	3240	3910	5245	5450
1050		290	350	685		430	525	1030		816	1949	2040		1296	1572	3094	3240		2160	2625	5155	5400
1100		190	220	610		290	330	915		544	1729	1711		864	988	2748	2716		1440	1645	4575	4525
1150		125	135	475		185	205	710		351	1342	1263		556	616	2128	2004		925	1030	3550	3345
1200		75	80	370		115	125	555		215	1049	816		340	372	1668	1296		565	615	2775	2160
1250				295				440				834				1328					2210	
1300				235				350				662				1048					1750	
1350				190				290				544				864					1440	
1400				150				225				430				680					1130	
1450				115				175				329				524					875	
1500				85				125				233				373					620	
	Nota 4	Nota 5	Nota 5	Nota 6	Nota 4	Nota 5	Nota 5	Nota 6	Nota 4	Nota 5	Nota 5		Nota 4	Nota 5	Nota 5	Nota 6	Nota 4	Nota 5	Nota 5	Nota 6		

Operating temperature °C	Max operating pressure bar ASME Class 600				Max operating pressure bar ASME Class 900				Max operating pressure bar ASME Class 1700				Max operating pressure bar ASME Class 2700					Max operating pressure bar ASME Class 4500						
	Material Schedule				Material Schedule				Material Schedule				Material Schedule					Material Schedule						
	71	11	22	31	71	11	22	31	71	11	31	91	71	11	22	31	91	71	11	22	31	91		
-29 +38	102,1	103,4	103,4	99,3	153,2	155,2	155,2	149	289,5	293,1	281,4	293,1	459,5	465,5	465,5	446,9	465,5	766,1	775,8	775,8	744,8	775,8		
50	100,2	103,4	103,4	96,3	150,2	155,2	155,2	144,5	283,9	293,1	272,8	293,1	450,7	465,5	465,5	433,3	465,5	751,3	775,8	775,8	722,2	775,8		
100	92,8	103	103,1	84,5	139,1	154,5	154,5	126,8	262,9	291,8	239,1	292,1	417,5	463,4	463,9	379,8	463,9	695,6	772,3	773,1	633,2	773,1		
150	90,5	99,6	100,3	77,1	135,7	149,2	150,6	115,7	256,2	281,9	218,1	284,4	407,1	447,6	451,8	346,5	451,8	678,4	746,2	752,9	577,6	752,9		
200	87,6	95,8	97,5	71,2	131,5	143,9	146,2	107	248,4	271,7	202,2	276,5	394,4	431,6	439,1	321,0	439,1	657,3	719,6	731,8	535,1	731,8		
250	83,4	92,4	92,7	66,7	125,2	138,6	139,1	100,3	236,5	261,8	189,3	262,7	375,5	415,7	417,1	300,4	417,1	625,8	692,6	694,9	500,8	694,9		
300	77,5	85,8	85,8	63,1	116,2	128,6	128,6	95	219,5	243,0	179,2	243,0	348,6	385,8	385,8	284,6	385,8	581,0	642,7	642,7	474,5	642,7		
350	73,9	80,4	80,4	61	110,9	120,7	120,7	91,3	209,5	227,9	172,6	227,9	332,7	362,2	362,2	274,1	362,2	554,4	603,4	603,4	456,9	603,4		
375	72,9	77,6	77,6	59,9	109,4	116,5	116,5	89,8	206,7	219,9	169,3	219,9	328,2	349,1	349,1	269,0	349,1	546,8	581,9	581,9	448,3	581,9		
400	69	73,3	73,3	58,9	103,5	109,8	109,8	88,2	195,5	207,5	166,8	207,5	310,5	329,3	329,3	265,0	329,3	517,5	548,6	548,6	441,8	548,6		
425	57,5	70,2	70,2	58,3	86,3	105,5	105,5	87,3	163,1	199,0	165,1	199,0	258,9	315,9	315,9	262,3	315,9	431,2	526,3	526,3	437,2	526,3		
450	40,1	67,7	67,7	57,7	60,1	101,4	104,4	86,7	113,7	191,6	163,6	191,6	180,4	304,4	304,4	259,7	304,4	300,4	507,1	507,1	432,8	507,1		
475	27,1	63,4	63,4	57,3	40,6	95,1	95,1	86	76,9	179,4	162,5	179,4	122,0	285,0	285,0	258,1	285,0	203,0	474,9	474,9	430,2	474,9		
500	17,6	50,6	55,7	54,8	26,4	75,7	83,4	82,1	50,0	142,9	155,0	159,7	79,3	227,0	250,3	246,3	253,9	132,0	378,5	417,3	410,4	423,1		
525	10,4	36,3	43,3	50,7	15,5	54,5	64,9	75,9	29,5	102,9	143,3	146,2	46,7	163,4	195,0	227,5	232,2	77,7	272,4	325,3	379,1	386,8		
550		25,4	30,7	47,8		38,1	46,1	71,8			72,0	135,7	141,5			114,4	138,2	215,4	224,7		190,7	230,6	359,0	374,3
575		17,7	21,1	45,5		26,4	31,6	68,3			49,9	129,2	133,0		79,2	94,7	205,2	211,1		132,1	158,0	341,9	351,9	
600		12	13,8	39,8		18,3	20,7	59,7			34,3	112,8	110,6		54,5	62,0	179,2	175,5		90,8	103,3	298,5	292,5	
625		8,1	8,8	31,7		12,1	13,4	47,5			22,9	89,7	82,8		36,3	40,1	142,3	131,4		60,3	67,0	237,3	219,2	
650		5,2	5,5	25,3		7,9	8,6	38			14,8	71,7	56,3		23,4	25,7	114,1	89,4		39,0	42,4	189,8	149,0	
675				20,7				30,8				58,4				93,0					154,7			
700				16,9				25,1				47,5				75,4					125,8			
725				13,9				21,1				39,6				62,9					104,9			
750				11,3				17,1				32,5				51,5					85,6			
775				9				13,7				25,9				41,1					68,4			
800				7				10,5				19,8				31,5					52,6			
	Nota 4	Nota 5	Nota 5	Nota 6	Nota 4	Nota 5	Nota 5	Nota 6	Nota 4	Nota 5	Nota 5		Nota 4	Nota 5	Nota 5	Nota 6	Nota 4	Nota 5	Nota 5	Nota 6				